

DEVELOPMENT OF A TWO-CIRCUIT HEAT PUMP FOR HEATING AND DOMESTIC HOT WATER SUPPLY

Bernd Müller, Institute of Power Engineering, Professorship of System Engineering and Heat Economy, Technische Universität Dresden

ABSTRACT

Advanced heat pump systems use low temperature heat sources of renewable energy from the ambient or / and of waste heat in an efficient way to provide heat on demand. Typical applications are space heating, domestic hot water supply and – to an increasing extent - combined heating and cooling with one device. This is possible either by direct cooling with ground coupled heat pumps or with reversible heat pump units. Due to better thermal insulation of the buildings the heat demand at low supply temperatures nowadays for floor heating is decreasing. In contrast the demand for a domestic hot water (DHW) supply at required temperatures of at least 60°C (to avoid possible growth of harmful bacteria) is increasing greatly.

The development of a heat pump is described. With the so called Two-Circuit Heat Pump it is possible to serve two different heat demands at different temperature levels. In parallel operation the heat of lower temperature from the condenser is fed for instance in the floor heating while the hot water tank is charged by the circuit of higher temperature from the desuperheater.

The design of a pilot-heat pump installation is described, measuring results obtained at a customer installation will be discussed and possibilities for optimisation pointed out. The coefficient of performance (COP) at different working points and the seasonal performance factor (SPF) will be discussed. The described heat pump system is a ground coupled (bore holes) brine / water heat pump supplying a low temperature floor heating and domestic hot water production.

Key Words: *heat pumps, heat pump equipment, domestic hot water generation, heat pump measurement.*

1 INTRODUCTION

The demands of an advanced heat pump system are determined by the heating task. Two essential but different fields of application are the new building and the reconstruction of the heating systems for old buildings. While for new buildings a flow temperature of maximally 35°C is possible due to low temperature floor heating systems, in the reconstruction of old heating systems higher flow temperatures due to mainly radiators are necessary.

Due to better thermal insulation of the new buildings the heat demand at low supply temperatures is decreasing. Contrary to that the domestic hot water supply at required temperatures of at least 60°C to avoid possible growth of harmful Legionella bacteria is highly increasing.

Instructions of DVGW Arbeitsblatt W 551 / W 552 (DVGW 2004) regarding Legionella are to be taken into account. According to this standard domestic hot water heating systems are divided into small and large units. Small units are all DHW heating systems within detached houses and within two-family houses. Small units are also installations of DHW heating tanks with a volume ≤ 400 l and a volume ≤ 3 l within each tube between tank and tap. For small units the hot water temperature of 60°C is recommended. Temperatures below 50°C should be avoided.

A weak spot of customary heat pumps is the domestic generation of hot water since the SPF decreases as a result of higher flow temperatures. To receive a better SPF (Seasonal Performance Factor)

very often the domestic hot water is generated by insufficient low temperatures of about 40°C to 45°C. On account of energy saving auxiliary electric heater for storage tank disinfection are usually not used. In the course of our research work we did a lot of investigations on the so called Two- Circuit-Heat Pump (Zschernig; Klinger 1996) and (Preußer 2003). This means that we utilize two circuits of useful heat within one device as shown in Fig. 1.

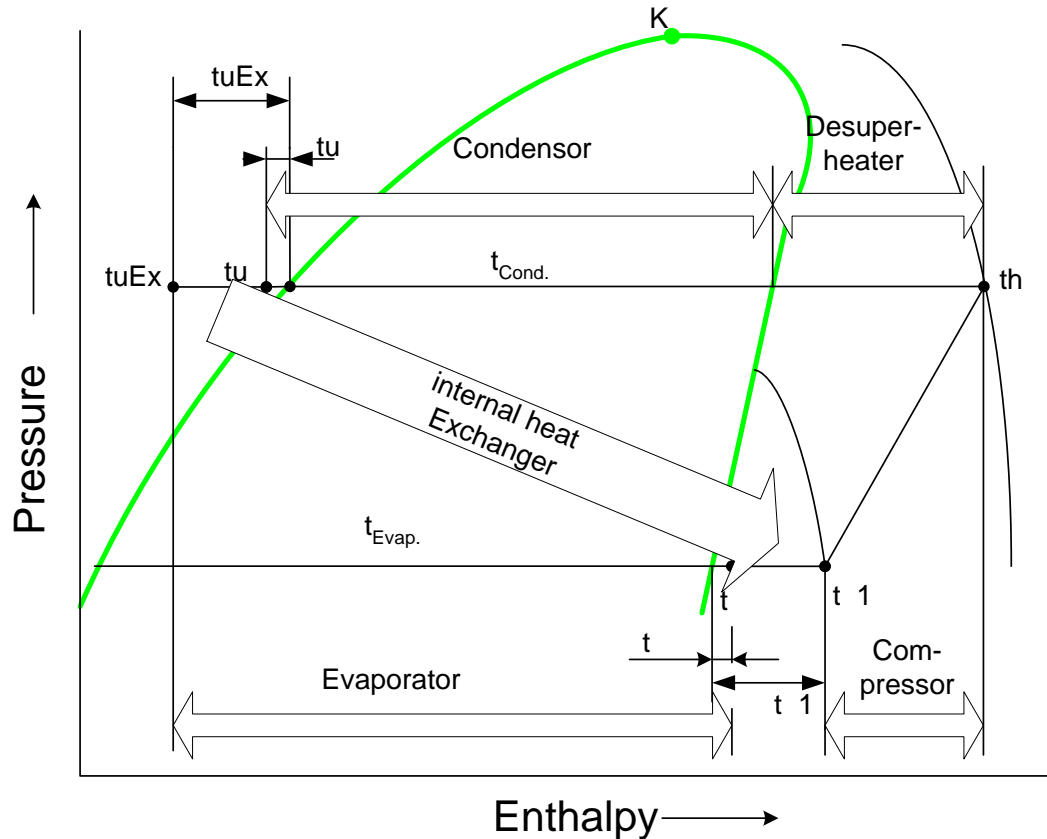

Fig. 1. Logarithmic Pressure, Enthalpy- Diagram

Figure 2 shows the schematic of the heat pump circuit. One loop of heating circuit water is connected with the condenser and the other one of higher temperature water is coupled with the desuperheater.

In parallel operation the heat of lower temperature is fed for instance into the floor heating system while the hot water tank is charged by the circuit of higher temperature from the desuperheater. The following characteristic features describe the exemplary heat pump process.

- The compressor K1 (an air conditioning, refrigeration and heat pump application Copeland Scroll-ZR compressor) works with superheated suction gas due to the internal heat exchange (WÜ4). Care must be taken to avoid too high discharge temperatures (th). If necessary, suitable compressor cooling methods have to be used.
- The expansion valve must be able to work with larger subcooling.
- The large liquid subcooling reduces the losses by throttling device.

- The liquid subcooling by internal heat exchange has a positive effect on heat pump process as heat of subcooling is moved to the heat utilization side and thus a higher enthalpy and a larger thermal output is available.
- With rising discharge temperature and an increasing amount of desuperheating the mean temperature of heat supply will rise and thus usable exergy.
- The internal heat exchange from the condensed refrigerant to the suction gas has a positive effect on the heat source side as the necessary suction gas overheating can take place for the most part within the internal heat exchanger with the result of higher evaporating temperature.

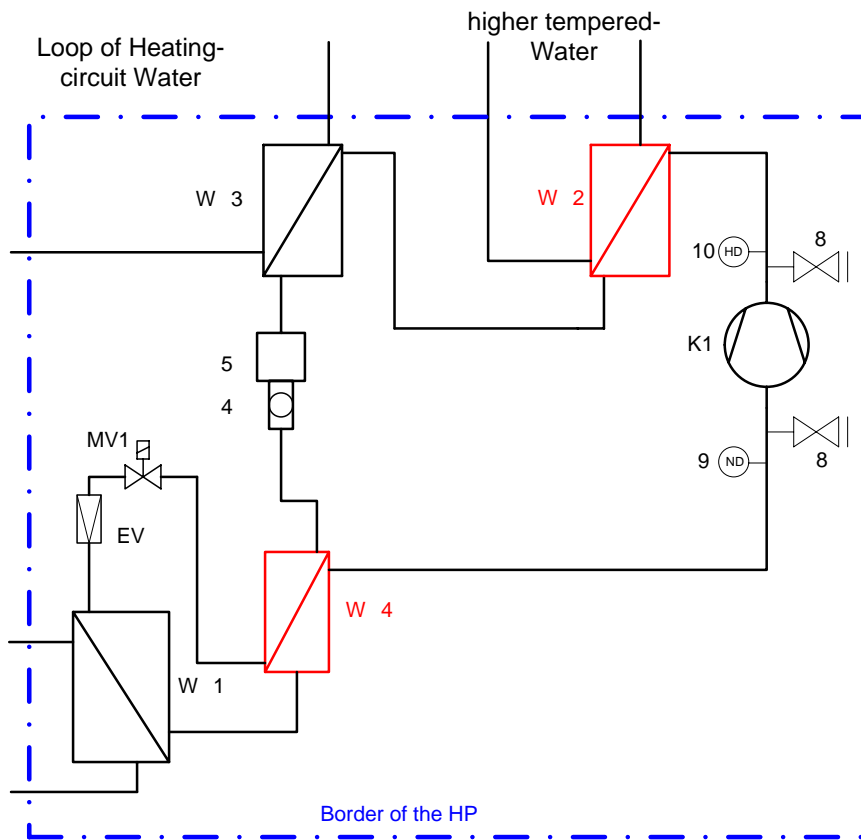

Fig. 2. Schematic of the Heat Pump Circuit

1.1 Design of a Two-Circuit Pilot Heat Pump System

The heat pump system shown in Fig. 3 is a ground coupled brine / water heat pump. It is the heating installation of a detached house which was built in a Dresden suburb. In the test rig in the laboratory, propane was used as a natural refrigerant while the heat pump of the pilot-plant installed in the detached house is charged with R 134a. The deciding factor for this choice is product liability.

The heat source consists of two boreholes each with a depth of 60 m. The heat usage system consists of a floor heating and a domestic hot water storage tank of 400 l. Within the storage tank there are two heat exchangers one on the upper part and the other one below.

The heat pump control is dependent on the heating load of the building (dependent on the outdoor temperature).

Parallel to the operating condition heating the heat from the desuperheater is fed to the domestic hot water tank via three-way-valve (3WV1) and the upper heat exchanger (WÜo). If the storage water will reach a certain temperature e.g. about 60°C the desuperheating heat will charge the lower part of the storage tank via three-way-valve (3WV2) and the lower heat exchanger (WÜu).

These operating conditions occur predominantly during winter and on cold days in spring or autumn. If there is no heating demand for instance in summer and domestic hot water temperature is below the required temperature, domestic hot water will be produced by the heat pump within the condenser and is fed to the lower heat exchanger (WÜu) via three-way-valve (3WV2).

Parallel to this operating condition heat at higher temperature charges the upper part of the domestic hot water tank.

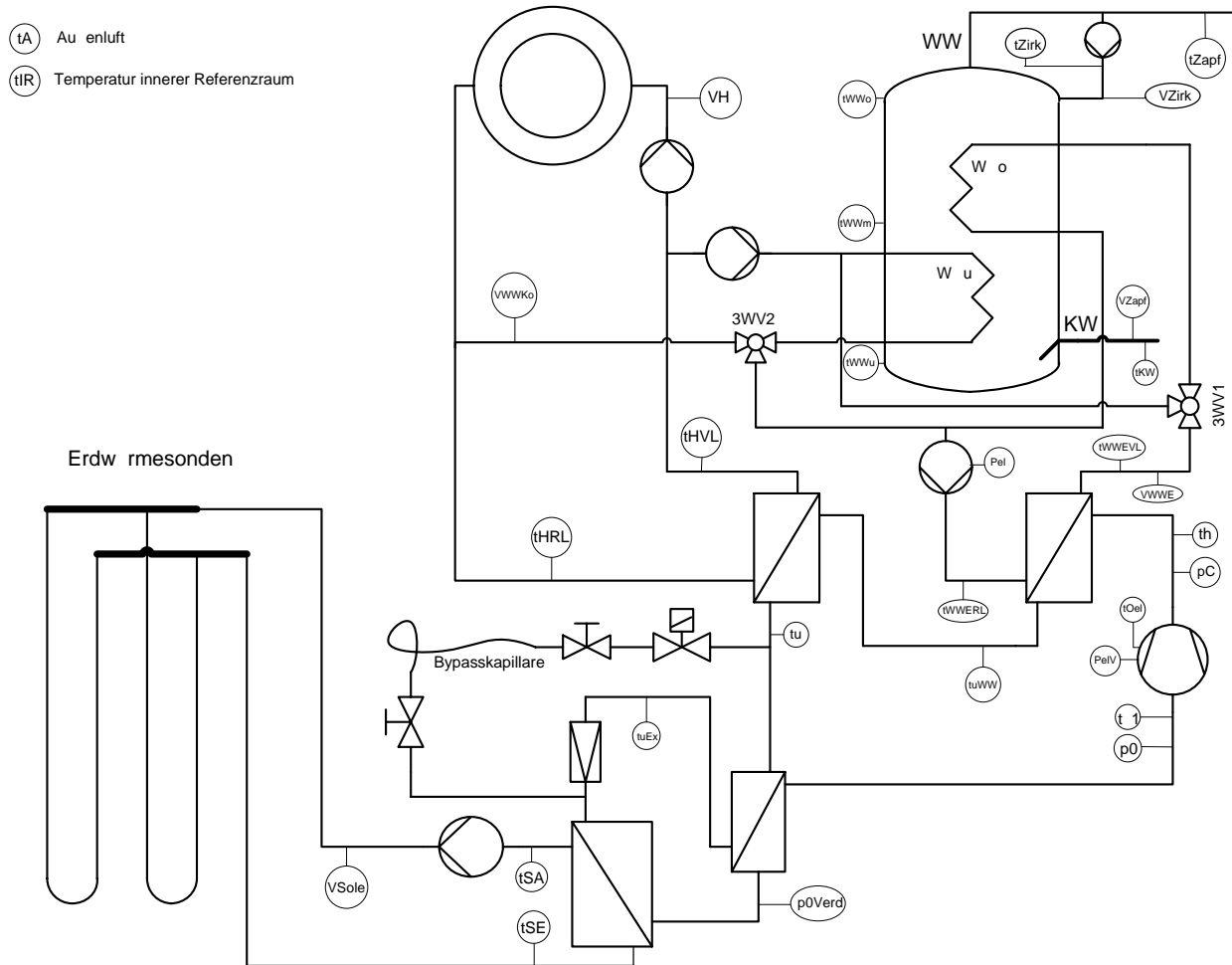

Fig. 3. Schematic of the Heat Pump System

1.2 Measuring Results

Typical operation conditions are shown in the following diagrams. In Fig. 4 temperature lines are represented for a winter day. During the operating condition heating the domestic hot water storage tank is charged by desuperheating heat. It is visible that after raising the top water temperature up to nearly 60°C the lower part of the tank is charged. After a larger consumption of hot water in the evening the temperature in the middle of the tank falls below 45°C and thus hot-water production is demanded by control device. In this case the DHW is produced under condensing conditions and at higher flow temperature.

Figure 5 shows the temperature lines of a typical summer day. It is seen that without any heat demand the domestic hot water is produced under condensing conditions. The strong fall in the bottom temperature results from the lack of insulation of the bottom of the tank and the connections. Some improvements were made later.

In Fig. 6 the monthly amounts of heat in kWh are shown. In all months with a high number of heating hours the amount of desuperheating heat for domestic hot water generation is high. On summer days hot water generation by condensing heat is increasing.

Discussing the SPF at Fig. 7 we have to take into account that the house was built late in 2003. The indoor work was done during the winter of 2003 to 2004. There was a lot of dampness inside the house and the heat pump cooled down the heat source more than usual.

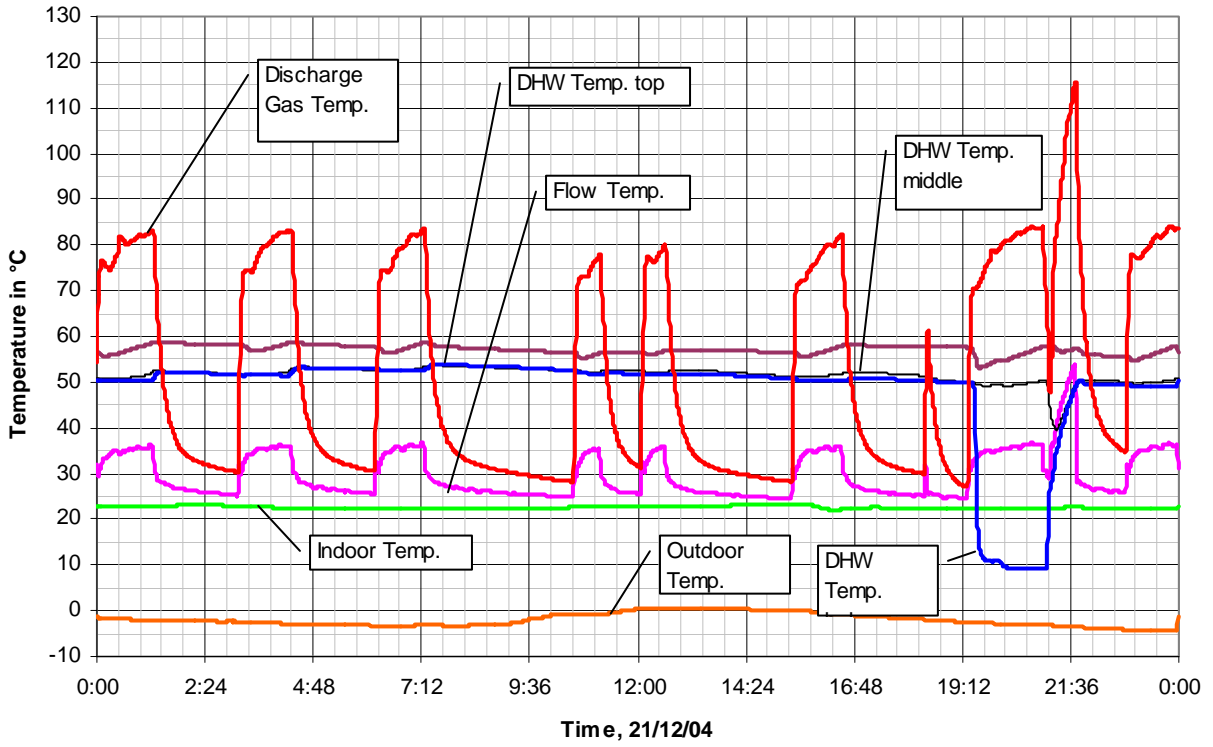

Fig. 4. Typical behaviour on a winter day

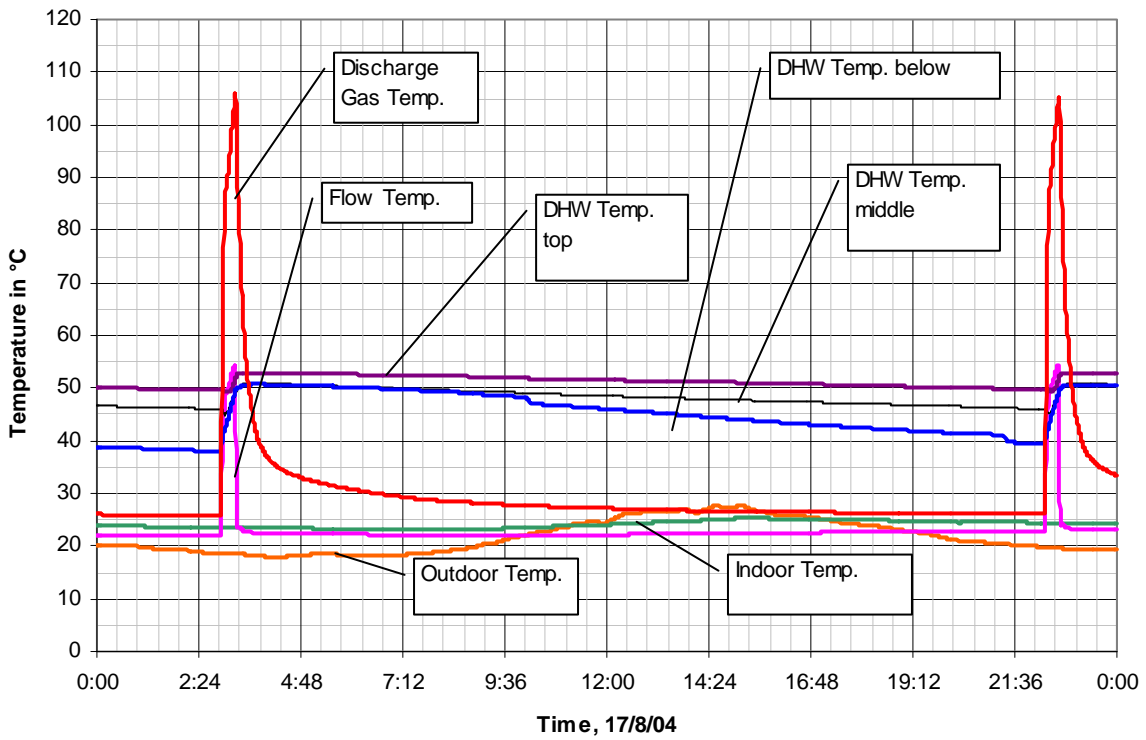

Fig. 5. Typical behaviour on a summer day

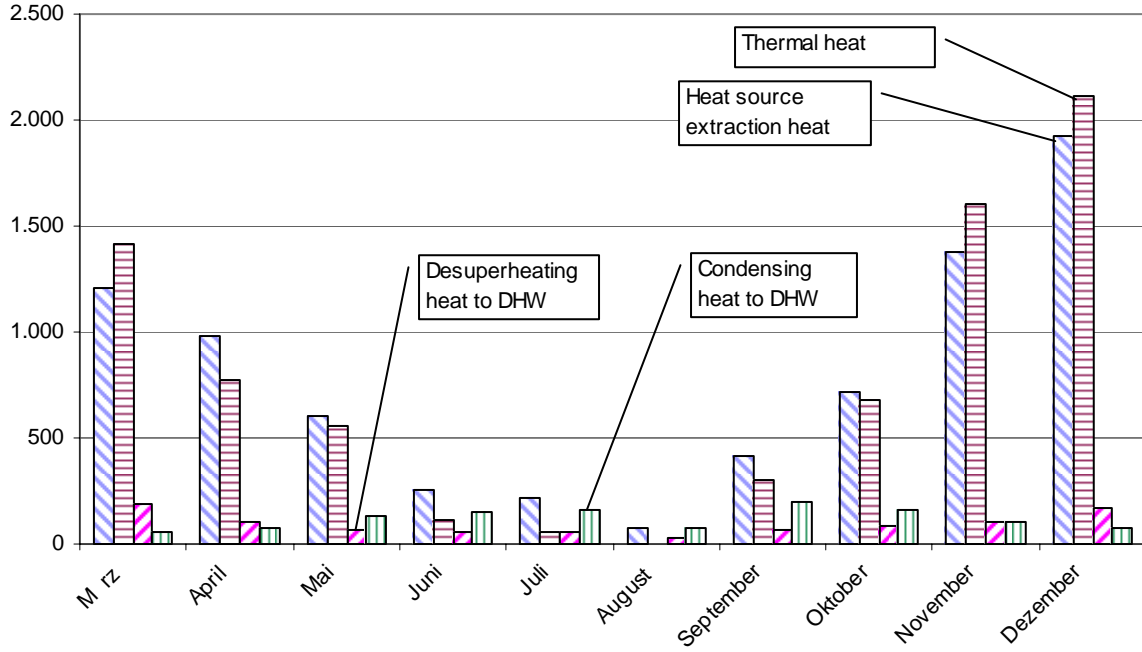

Fig. 6. Amounts of heat per month in kWh

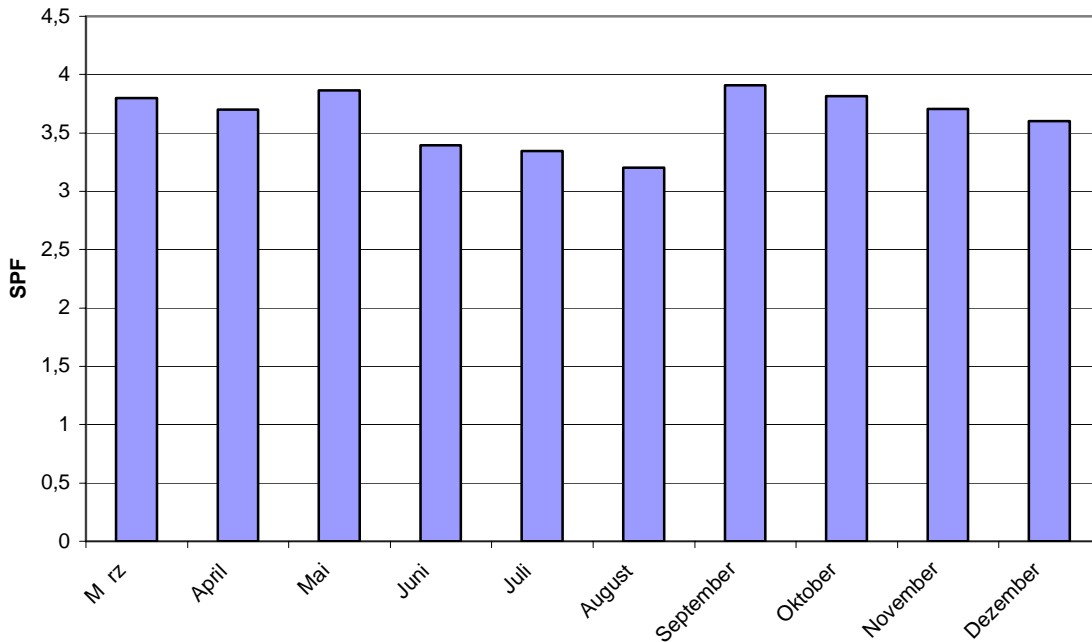

Fig. 7. Seasonal Performance Factor of the installation

At the beginning of September there were some improvements done at the expansion valve and at the control adjustment. An evaluation of data measured indicate there are still some possibilities to

improve the performance of the installation. It is planned that the measurements will take some heating periods to get more information about the behaviour of the plant and to work out still more improvements in design and control technology.

REFERENCES

DVGW Deutsche Vereinigung des Gas- und Wasserfaches e.V. 2004, Trinkwassererwärmungs- und Trinkwasserleitungsanlagen; Technische Maßnahmen zur Verminderung des Legionellenwachstums; Planung, Errichtung, Betrieb und Sanierung von Trinkwasser-Installationen

Preußner S. 2003. Anwendungsgerechte Gestaltung von Wärmepumpen-Kreisprozessen und –Anlagen, *Dissertation TU Dresden*

Zschernig J., Klinger S. 1996. The Development of Highly Efficient Heat Pumps with New Refrigerants and a Demand-Meeting Differential Heat Output, *International Energy Agency Conference on Heat Pumping Technologies*