

IEA Heat Pump NEWSLETTER

CENTRE

Volume 25
No. 1/2007

Industrial
applications

Industrial high-temperature heat pumps for wood drying

Application of Ammonia Heat Pumps in Norway

Thermally Powered Heat Pump/Chiller Sets New Efficiency Standard

In this issue

Industrial applications

Dear readers,

This issue is about heat pumps that are not so many by the numbers, but does a horse job because of their size – industrial heat pumps. There are many things that differ in their design compared to domestic heat pumps, and their working temperature range is much wider. Please be inspired by the articles, and have a good (late) spring!

Roger Nordman
Editor

COLOPHON

Copyright:
© IEA Heat Pump Centre

All rights reserved. No part of this publication may be reproduced, stored in a retrieval system, or transmitted in any form or by any means, electronic, mechanical, photocopying, recording or otherwise, without prior permission of the IEA Heat Pump Centre, Borås, Sweden.

Published by IEA Heat Pump Centre
Box 857, SE-501 15 Borås, Sweden
Phone: +46 10 516 55 12
Fax: +46 33 13 19 79

Disclaimer IEA HPC
Neither the IEA Heat Pump Centre, nor any person acting on its behalf:

- makes any warranty or representation, express or implied, with respect to the accuracy of the information, opinion or statement contained here in;
- assumes any responsibility or liability with respect to the use of, or damages resulting from, the use of this information;

All information produced by IEA Heat Pump Centre falls under the jurisdiction of Swedish law.

Publisher:
IEA Heat Pump Centre
PO Box 857, S-501 15 BORAS
SWEDEN
Tel: +46-10-516 50 00, Fax: +46-33-13 19 79
E-mail: hpc@heatpumpcentre.org
Internet: <http://www.heatpumpcentre.org>

Editor in chief: Monica Axell
Technical editing: Roger Nordman,
Ulf Mårtensson - IEA Heat Pump Centre
Language editing: Neil Muir, Angloscan Ltd

Heat pump news

General.....	5
Working Fluids.....	7
Technology & Applicatons.....	8
Markets.....	10
IEA Heat Pump Programme	12

Features

Foreword	3
Columnist.....	4
Books & Software	33
Events.....	34
National Team Contacts	35

Topical article

Industrial high-temperature heat pumps for wood drying	14
Application of Ammonia Heat Pumps in Norway	20
Thermally Powered Heat Pump/Chiller Sets New Efficiency Standard	24

Non-Topical article

Coabsorbent heat pumps for the future	29
---	----

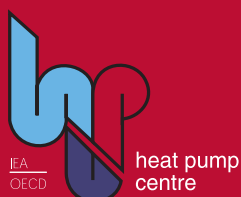



Monica Axell
Manager, HPP Heat Pump Centre,
Sweden

Industrial applications have not been covered by the IEA Heat Pump Centre Newsletter since 1999. The global energy use in the industrial sector is about 2000 Mtoe (about 40 % of the energy usage). Improved energy efficiency is identified as one of the most important actions by IEA to reach environmental targets on a global level.

IEA has defined the following advantages with improved energy efficiency:

- Substantial reduction of energy and greenhouse gas emissions
- Energy security and reliability benefits
- Enhanced business competitiveness and social welfare

Energy conservation in the industrial sector is a continuously ongoing process since many years ago, but there is still room for further improvements. The external factors influencing the decisions have changed during the last years. Energy prices have increased and the cost relation between different primary energy sources have changed, and new standards and directives are implemented, influencing the decision making process for preferred actions to be made. Rapidly changing external factors are a challenge for the industry who wants stable, long-term policies.

A lot of waste heat is produced in industry, and with higher energy prices the interest for using waste heat is growing. Only in Sweden there is a potential of about four to five TWh.

Heat pumping technology for the industrial sector is characterized of customized build equipment. Few heat pumps are installed in the industrial sector compared with building sector but size of the heat pumps are large and therefore improvements can have substantial impact on reduction of energy and greenhouse gas emissions. Many heat pumps were built during 1980 and retrofitting in the industry with energy efficient heat pumps can have a large impact for the future energy system. Industry is used to work with reliability and safety and this could be advantage in the process of deciding refrigerants in future heat pumps. A lot of interesting actions are expected in the industrial sector and some news is covered by this Newsletter.

Monica Axell
Manager, HPP Heat Pump Centre
Sweden

New research for industrial heat pumps needed?!



*Roger Nordman
Editor of the HPC Newsletter
Sweden*

Heat pumps in industry are to a large extent custom made machines, and they are mostly assembled on-site. Technology often consist of off-the-shelf components that are put together in the final design. Multistage and “exotic” cycles are often used, and can be used since there is often one single point of operation due to the steady-state conditions in industrial processes.

Refrigerant is quite often water because of its good thermodynamic properties at the high temperatures often required, but there exist a number of other refrigerants as well, many of which have quite high GWP numbers.

Research aiming to improve industrial heat pumps have been carried out in the past, e.g. the Japanese “Waste heat utilization project” in the 1970-ties, the “Super Heat Pump” project in the 1980-ies and the IEA HPP Annex 21 that was closed in 1996.

With rapidly changing energy prices, objectives for reducing GHG emissions and “environmentally concerning” attitude there is an increased interest for heat pumps in industrial applications, and there is much research work than can be made.

Examples include the use of new high-efficient heat exchangers, ejectors and the development of new high-performance, low-GWP refrigerants for the high-temperature range.

Example of successful applications are presented in this issue, which may be an inspiration for new research programmes in the area of Industrial heat pumps.

*Roger Nordman
Editor of the HPC Newsletter
Sweden*

General

Carmakers criticise EU plans for CO₂ limits

Europe European automakers joined together to show a united front against EU proposals to limit CO₂ emissions from new cars to 120 grams per kilometre. But internal divisions remain as to how the burden of cuts should be shared between manufacturers.

The new strategy would commit vehicle manufacturers to cutting average emissions from new cars to 130 g/km by 2012 through vehicle technology improvements, while asking other players, including tyre-makers, fuel suppliers, repairers, drivers and public authorities, to contribute to a further 10 g/km reduction.

The new law would replace a 1998 voluntary agreement signed with ACEA, the EU's Automobile Manufacturers Association, which committed carmakers to achieve a target of 140 grams of CO₂ per kilometre by 2008.

Concrete measures for realising these targets are yet to be decided upon. The Commission has said that it will announce proposals during 2007.

Comment from the editor: With mobile air conditioning being driven by engine power, there is a link (even if small) to the efficiency of the AC and CO₂ emissions.

Source: EurActiv Newsletter

CGC Publishes Municipal Policy Roadmap for GeoExchange™ Technology

Canada First-ever guidelines rolled out through cooperation with cities across Canada.

Region of Peel, March 27, 2007 –The Canadian GeoExchange™ Coalition (CGC) announced today the publication of Canada's first comprehensive

guideline document on integrating renewable GeoExchange™ technology into municipal government frameworks. The document, 'Prioritized Recommendations to Advance GeoExchange™ Amongst Municipalities', follows a road-mapping exercise conducted by CGC in 2006, and serves as the project's final report. During the exercise, officials and stakeholders from Springhill, Nova Scotia to Kelowna BC and Yellowknife, NWT participated in a series of conference calls and discussions to prioritize recommendations.

"This project was valuable for us because it not only talks about implementing what should be a key renewable technology for municipalities," stated Richard Schafer, Energy Projects Specialist for the Regional Municipality of Peel, ON, and CGC's board member representing municipalities. "It also captures a lot of recent information on renewable energy policy and can actually help municipalities implement policy for almost any renewable energy technology" he added.

The objective of the report is to make adoption of GeoExchange™ technology easier for municipalities than it has been in past.

The report is available for download from www.geo-exchange.ca.

2007 IEAA Calls for research are online

Europe Approximately €52 million are available in this new Intelligent Energy Europe call. The deadline for submitting proposals is 28 September 2007.

New in this call:

More funding per project

Up to 75 % of the eligible project costs will be supported: up from 50 % in previous years.

Simpler overhead calculation

A 60 % flat rate on direct staff costs will be applied to calculate indirect costs.

Focus on five policy objectives

Projects should be designed to contribute to enabling policies, market transformation, behavioural change, access to capital, and training.

Read more on http://ec.europa.eu/energy/intelligent/call_for_proposals/index_en.htm

Environment ministers have committed to achieve "at least a 20% reduction" in EU greenhouse gas emissions by 2020

Europe Environment ministers have committed to achieve "at least a 20% reduction" in EU greenhouse gas emissions by 2020, but failed to agree on how to share the burden between the 27-nation bloc.

The Environment Council has backed calls for developed countries to "take the lead" in tackling global warming, stating on 20 February 2007 that EU member states are "willing to commit to a reduction of 30 %" in greenhouse gas emissions by 2020. However, the 30 % cut would only take effect "provided that other developed countries commit themselves to comparable emission reductions" in the context of international negotiations for the period after 2012, when the Kyoto targets expire.

If negotiations failed, the ministers agreed that the EU would go it alone. "The EU makes a firm independent commitment to achieve at least a 20 % reduction of greenhouse gas emissions by 2020 compared to 1990," the ministers said in a statement. The ministers' conclusions will be presented to EU leaders for final endorsement at a summit on 8-9 March in Brussels. They will then be followed up by a formal legislative proposal later in the year.

"We happily welcome the 30 % emission cut proposed for the EU and developed countries," said Mahi Sideri-



dou of Greenpeace. "Ministers have listened to the science and made a leap forward in addressing the climate crisis. But to then suggest a meagre 20 % unilateral EU emissions cut, while admitting that this is inadequate and that a 30 % cut will be necessary, is a bizarre discrepancy," Sideridou added.

Other environmental groups, however, were more optimistic. "After the endorsement of a target for renewable energy (20 % by 2020) by energy ministers last week, today's decision confirms the EU preparedness to fulfil its international commitments," said Stephan Singer, Head of WWF's European Climate and Energy Unit.

In separate discussions, the Environment Council said that "a differentiated approach" should be adopted to determine the precise contribution to be made by each member state in order to achieve the overall EU emissions reduction target.

But they failed to reach agreement after smaller member states, led by Finland, expressed concerns that the burden placed on their shoulders would be disproportionate compared with larger countries. The Council invited the Commission to start "immediately" an analysis of criteria to ensure that the EU burden is shared in "fairness and transparency" and "taking into account national circumstances".

Source: www.euractiv.com



Klima:aktiv „wärmepumpe“ at the Ener- giesparmesse Wels

Austria More than 102 000 visitors, from 61 nations, attended the Energiesparmesse in Wels in March 2007. All sectors in the fields of energy efficiency and energy-saving technologies achieved excellent results. The Austrian heat pump industry was extremely successful at the trade fair, with the klima:aktiv "wärmepumpe" also being demonstrated at the Energiesparmesse.

Austria's federal minister of Agriculture, Forestry, Environment and

Water Management, Josef Pröll, visited the members of klima:aktiv "wärmepumpe" scheme, and was impressed by the success that the programme management has achieved in the last year.

Further information and contact:
Klima:aktiv Programme Management

Mag. Martina Höller, Meisenweg 5,
4050 Traun

E: martina.hoeller@lgwa.at, T: +43
(0) 7229-70452

Further information:

- www.lgwa.at
- www.waermepumpe.klimaaktiv.at
- <http://eucert.fiz-karlsruhe.de>



Working Fluids

Pilot programme for natural refrigerants in Australia

Australia Australia is investing two million Australian dollars (roughly EUR 1.2 million) in developing climate-friendly refrigeration technology. The Government has approved a pilot programme under which new supermarkets will be equipped with refrigeration technology based on natural refrigerants. By using ammonia, carbon dioxide or hydrocarbons in the supermarket's refrigeration equipment, greenhouse gas emissions are to be reduced by more than 380 000 tonnes between 2008 and 2012. The project will be coordinated and managed by Australia's Natural Refrigerants Transition Board. "We will also support advanced training measures in the field of refrigeration with natural refrigerants, since the lack of qualified technicians is impeding a more rapid spread of this climate-friendly technology," says Dr. Michael Bellstedt, Executive President of the Natural Refrigerants Transition Board (NRTB). The NRTB is a non-profit organisation that promotes the use of natural refrigerants in the Australian refrigeration sector.

Source: www.eurammon.com

DuPont, Honeywell announce joint development

DuPont and Honeywell have announced a global joint development agreement to accelerate the development and commercialisation of next-generation, low global warming refrigerants for the automotive air conditioning industry.

The new refrigerants would enable automakers to meet new regulations in Europe that require the use of low global warming potential (GWP) refrigerants in mobile air conditioning (AC) applications. Today's automotive air conditioners use hydrofluorocarbon (HFC)-134a. The new regula-

tion is scheduled to take effect in 2011 for new model automobiles, with the transition complete by 2017.

Under the agreement, DuPont and Honeywell will jointly identify, develop, test and qualify new low-GWP refrigerants that are cost-effective alternatives to other technologies being considered by the auto industry. Automakers are currently evaluating mobile AC systems that use such technologies

The two companies plan to share resources, investment and technology as part of the agreement, and will work closely with the automotive industry to qualify a low-GWP alternative by mid-2007.

Based on a test conducted by DuPont comparing mobile AC systems utilizing DuPont's low-GWP replacement refrigerant and CO₂, widespread utilization of a fluorine-based refrigerant could lead to worldwide emissions reduction equivalent to 230 million gallons of fuel per year by 2017.

Source: *DuPont and Honeywell International*

New web site for CO₂ in MAC applications established

R744.com is a new site for CO₂ components, news and policy regarding Mobile Air Conditioning (MAC).

What can I find on R744.com?

This new service will keep you abreast of all developments on R744 (CO₂) in a user-friendly way. The web site provides information and updates covering:

- News on R744 development
- Components for R744 systems
- Policies and legislation worldwide
- Upcoming conferences and events

Who should use it?

- Anyone with an interest in alternative refrigeration systems for vehicles.

- Engineers from automotive Original Equipment Manufacturers (OEMs) and system / components suppliers developing CO₂ systems.
- Public authorities worldwide, as well as Media and NGOs following climate change and environmental technologies.

How did it start?

Facing the market's increasing need for more and better information on CO₂ technology, Shecco™ decided to launch this portal. With the support of the VDA (Verband der Automobilindustrie) and Obrist Engineering, Shecco took the initiative to provide an open platform for all those interested in the technological, economic and environmental benefits of R744.

Source: www.r744.com

New natural refrigerants web site launched

The web site for the Initiative to establish a Natural Refrigerants Fund has been launched. Please visit www.nrfund.org for more information.

Contact:

Prof. Dr. Risto Ciconkov
ristoci@ukim.edu.mk

Three more commit to HFC phase-out

Three more big-name companies have committed to HFC-free refrigeration under the Refrigerants, Naturally! initiative.

Carlsberg, IKEA and PepsiCo have now joined Unilever, Coca-Cola and McDonalds as companies pledged to stop using HFCs in their food and drink, food service and retail sector activities.

In 2005, the Refrigerants, Naturally! Initiative was the recipient of the US Environmental Protection Agency's Climate Protection Award.

Source: *ACR news*



Technology & Applications

Nanotechnology insulation could reduce fridge running costs

An insulating material using the latest nanotechnology could reduce the energy consumption of refrigeration units by as much as 20 %, it is claimed.

The micron-thickness film, which provides a thermal protection layer by using small cells containing a vacuum, has been developed by British company General Applications. Called Nanoskin, it would be applied to the inner wall of a fridge during the manufacturing process to provide a highly effective added layer of insulation.

Source: *ACR news*

ASHRAE, ACCA publish load calculation standard

ATLANTA – A new standard that establishes minimum requirements for making load calculations has been published by the American Society of Heating, Refrigerating and Air-Conditioning Engineers. The standard was developed in conjunction with the Air Conditioning Contractors of America (ACCA).

ANSI/ASHRAE/ACCA Standard 183-2007, Peak Cooling and Heating Load Calculations in Buildings Except Low-Rise Residential Buildings, is available for purchase from www.ashrae.org/bookstore.

The standard establishes minimum requirements for building loads that are inclusive of as many procedural methods as possible, while identifying core elements that affect heat loss and gains. Requirements are non-prescriptive, and are aimed at ensuring that developers of load calculation methodologies observe recognized good practices. The spe-

cifics in calculating a load are left to the discretion of the industry professional by his/her selection and application of load methodologies that meet the standard.

The need for the standard was driven largely by the desire of the code enforcement community. Code references to the ASHRAE Handbook existed, making it the de facto standard.

The cost of Standard 183-2007, which is available in print or download versions, is \$24 (ASHRAE members, \$19).

Source: www.ashrae.org

Reducing TEWI of refrigeration systems by reducing the channel size of heat exchangers

France The TEWI (Total Equivalent Warming Impact) makes it possible to measure the total impact of a system on global warming. The direct effect is produced by refrigerant loss. The indirect effect is produced by the CO₂ released when producing the electricity operating the system. In order to minimize this, Cemagref is seeking to reduce the overall TEWI of refrigeration systems by reducing the size of the heat exchangers' channels. The studies aimed primarily at demonstrating that the use of mini-channels was compatible with thermal and energy efficiency. Fundamental research concentrated on pressure drops in small-diameter pipes, and modelling energy efficiency and consumption. This led to the construction of a prototype allowing for a 10-fold reduction in refrigerant for the same energy efficiency. The applications concerned account for 16 000 tonnes of refrigerant, which could be reduced to 2000 tonnes, not to mention potential air-conditioning applications. The direct TEWI could

be reduced by 90 % and the indirect TEWI by 10-20 %, which led to an expected overall TEWI reduction of approximately 50 %. Applying this technology to the 600 000 systems in France alone could lower CO₂ equivalent annual emissions by up to 1,2 million tonnes, i.e. approximately 2 % of the French energy sector's greenhouse gas emissions.

Source: <http://www.cemagref.fr>

Beta version of RET-Screen ice rink model released

Canada The CANMET Energy Technology Centre – Varennes of Natural Resources Canada has developed the new RETScreen model for assessing the viability of energy-efficient ice and curling rink projects, with a focus on heat recovery from refrigeration systems. The beta version of this decision support tool is now online, and can be downloaded from the RETScreen web site under the "Arenas & Supermarkets" heading in the download table:

<http://www.retscreen.net/>

This pre-feasibility study tool incorporates standard RETScreen capabilities and features. It aims at supporting decision makers, building owners, managers, and consultants of these targeted applications to evaluate different options for the implementation of new or retrofit heating, ventilation, air-conditioning and refrigeration (HVAC&R) systems.

Source: *CANMET Energy Technology*

The AC killer of airborne viruses

UK New air purification technology has been developed which could protect against airborne viruses such as bird flu and the hospital "superbug" MRSA, British scientists claim.

The technology could be incorporated into air conditioning equipment or used as stand-alone units in offices



to prevent the spread of winter colds and similar viruses, the Telegraph reports.

The Tri-Air system is a joint-venture company formed between Inventa Partners Ltd, the Building Research Establishment and the technology inventor. It uses three different decontamination technologies to simulate the production of fresh air, destroying infectious viruses and microorganisms.

Laboratory testing at Porton Down found the machine had a near-100 % kill rate on test viruses in less than five minutes.

BRE is currently seeking a manufacturing partner to produce the technology, and has employed the assistance of finance firm Price Waterhouse Coopers, who have contacted leading air-conditioning manufacturers Samsung, Sanyo, LG and Daikin, among others.

Source: RAC magazine

Fujitsu builds new R&D centre

Japan Japanese air conditioning manufacturer Fujitsu is to build a new R&D centre at its head office site in Kawasaki.

Scheduled for completion in September, the new stand-alone building will comprise five floors covering 20 000 m². The facility will include calorimeter and noise test rooms for large air conditioners. It will also be able to test multi air conditioning systems and verify performance.

Total investment will amount to around 5.5 billion yen.

Source: ACR news

Looking for Higgs? Cool down – a lot!

CERN's Large Hadron Collider (LHC) will be, when it is completed this year, the new research instrument of the world's elementary particle physics community. This discovery-making machine will explore the structure of matter and basic forces of nature on a scale never attained before. Research will focus in par-

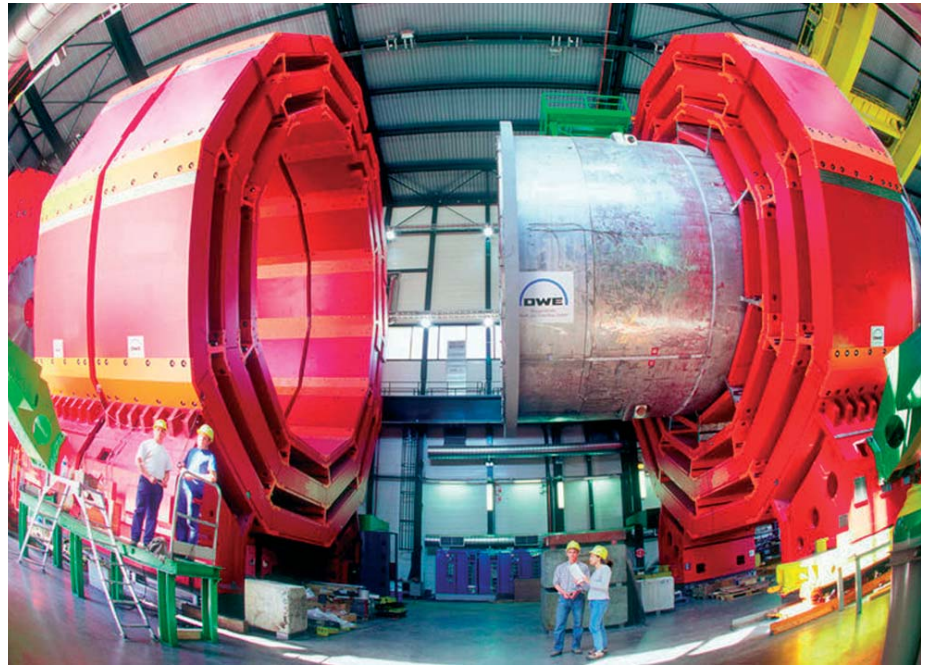

Photo: courtesy of www.cmsinfo.cern.ch

ticular on the Higgs boson, the hypothetical particle which plays a key role in explaining the origins of mass, but which has not yet been observed.

Beams of protons circulating in opposite directions along the 27-km-circumference LHC, at 99.999999 % of the speed of light, will be collided at the heart of four large detectors installed in deep underground caverns, where the resulting spray of particles is analysed and recorded. The LHC will produce up to 600 million such particle collisions per second. High-field superconducting magnets are required to guide and focus the beams. This requires high electrical currents, which can only be accommodated by superconducting windings made of niobium-titanium alloy offering no resistance to electricity, and therefore no thermal losses. To maintain the magnet windings in the superconducting state under high currents and high fields, they must be cooled down to $-271\text{ }^{\circ}\text{C}$, just $1.9\text{ }^{\circ}\text{C}$ above absolute zero, by sub-cooled helium. At this temperature, the helium becomes superfluid, i.e. it exhibits high thermal conductivity and minimal friction and viscosity. The magnets are thus better cooled, so that they can operate at a higher field and are better stabilized against thermal disturbances.

In view of the sheer scale of the project and of its technical novelty, specific technologies were developed over the years by CERN, national laboratories and the specialized industry, thus permitting construction to start a decade ago. While most of the components and technical systems were procured satisfactorily from industry in the twenty CERN member states, as well as in Canada, India, Japan, Russia and the USA, some difficulties plagued the procurement of the compound cryogenic line circling the ring, causing delay in the project installation. After vigorous corrective actions by CERN and the contractor, Air Liquide, this unprecedented installation was completed in October 2006 with a better performance than initially expected.

The LHC will constitute the largest helium cryogenic system in the world, with some 100 tons of liquid helium cooling 36 000 tons of equipment at a temperature "colder than outer space", as says Philippe Lebrun, who is in charge of the main technical systems of the project and President of the IIR's Commission A1.

Source: www.iifir.org

Markets

BSRIA publishes market analysis of the world market for air conditioning

The analysis includes data for 29 countries, with key market analysis for windows, moveables, minisplits, rooftops, indoor packaged units, ducted splits, chillers, fan coils and AHUs. Information includes market size (2005-2010), supplier information and expert commentary.

Products covered:

- Minisplits
- Windows and moveables
- Large packaged and close control
- Chillers
- Air handling units and fan coils
- Stock levels (minisplits) - selected countries only

Source: www.bsria.co.uk

20th Anniversary Awards/Contests

In honour of the 20th Anniversary of the Montreal Protocol, the Ozone Secretariat will, in cooperation with selected judges/judging panels, be issuing a variety of recognition awards, all of which are now open for nomination. To send in nominations for the awards listed below, visit <http://ozone.unep.org>

RECOGNITION AWARDS

Visionaries award: Recognizing extraordinary contributions in the creation of the infrastructure of the Montreal Protocol and/or its Multilateral Fund.

Outstanding Contributors Award: Recognizing extraordinary contributions of those who took the vision of the founders and advanced it to address more modern issues.

Implementers Award: Recognizing extraordinary contributions from some of the national ozone units and/or people whose hard work on the country level over the years has helped to make the Protocol's phase-

out goals a reality.

Innovators Award: Recognizing the extraordinary contribution of companies/entities whose daring and/or hard work facilitated the widespread implementation of alternatives or alternative technologies that enabled the phase-out of ozone depleting substances to take place.

Partners Award: Recognizing the work of civil society and other international organizations that have played a critical role in the development and/or implementation of the Montreal Protocol.

Exemplary Projects Awards: Recognizing a sample of the outstanding projects developed and implemented through the work of the Multilateral Fund.

Public Awareness Award: Recognizing outstanding efforts at raising the public's awareness of the ozone depletion issue.

Source: <http://ozone.unep.org>

ARI applauds reintroduction of legislation to help America meet energy conservation, clean air goals

USA Arlington, VA (April 18, 2007) – The Air-Conditioning and Refrigeration Institute (ARI) today applauded U.S. Rep. Peter Hoekstra, (R-MI), for reintroducing legislation that would provide an incentive for building owners to replace inefficient cooling equipment with modern technology. The Cool and Efficient Buildings Act (H.R. 1888) would amend the U.S. tax code to reduce the depreciation period for commercial cooling systems — large-tonnage liquid chillers to commercial air conditioners and heat pumps — from the current 39-year period to a more realistic 20 years. A wide range of commercial buildings, from shopping malls to hospitals, would qualify for the new depreciation rate.

"Our industry has made great strides

in improving the efficiency of cooling and refrigeration systems to help the nation, and the world, reduce energy consumption, and lessen the environmental impact of this equipment," said ARI President Stephen Yurek. "Unfortunately, the replacement of older, inefficient cooling systems that use ozone-depleting refrigerants has been slower than expected, partly due to the tax code."

The legislation would spur the replacement of more than 35 000 chillers using ozone-depleting chlorofluorocarbon refrigerants, which still operate in North America, with equipment that is 40 percent more efficient and uses refrigerants that are less detrimental to the earth's ozone layer.

Source: www.ari.org

Danish subsidies for heat pumps

The Danish Government has decided on a DKK 30 million programme for replacing oil boilers in areas without district heating or natural gas. The money will be spent on standard approval certification, energy labelling of heat pumps and an information campaign. In addition, a grant for purchase of the most efficient products will be available for a limited time.

Source: *Scanref Newsletter*

Austria – Boom in heat pump sales in 2006

Austria Today, heat pumps are among the most environmentally friendly and efficient heating technologies available. In 2006, an increasing number of consumers therefore decided on a modern heating system with low heating costs and reduced CO₂-emissions. This boosted the demand for heat pumps used for heating, and caused a 45 % growth in the market.



Austrian residential heat pump market

All in all, 12 716 units of heat pumps were sold (for heating and hot water production), made up of:

- 8853 units for heating
- 3863 units for hot water production

The breakdown of the heat sources for the space heating heat pumps was as follows:

Most popular, with a market share of 71 %, were ground-coupled heat pumps. 52,2 % were brine/water heat pumps, and 17,8 % used direct vaporisation. Water/water heat pumps took 10,7 % of the market, followed by air/water heat pumps with 18,3 % market share.

Conquest of new markets

In terms of capacity, space heating heat pump sales were as follows:

- 0-20 kW 87,18 %
- 20 – 80 kW 12,18 %
- 80 kW and more 0.64 %

Market potential

The heat pump market in Austria is concentrated on new buildings, because these buildings offer ideal conditions for using heat pumps. Due to high building standards and the installation of low-temperature heat distribution systems, ground-coupled heat pump systems achieve high SPF's. However, there is a large market potential in the retrofitting sector, which at present does not account for many heat pump sales. This is largely due to the high temperatures required by existing hydronic systems, which also reduces the SPF.

Data sources

Both heat pump associations – LGWA and BWP – were responsible for collecting the data. 22 companies submitted their sales figures, representing nearly 100 % of the Austrian market. Professor G. Fanningner (PHD), under contract to the National Ministry for Transportation, Innovation and Technology, finalised the market statistics.

Source
 The Austrian Heat Pump Association
 Martina Höller
 PH: 0043-7229-70452
 E: martina.hoeller@lgwa.at

Austrian Federal Alliance of Heat Pumps
 Günther Mock
 PH: 0043-05-90900-3519
 E: info@bwp.at

Heat pumps 2006 in Austria

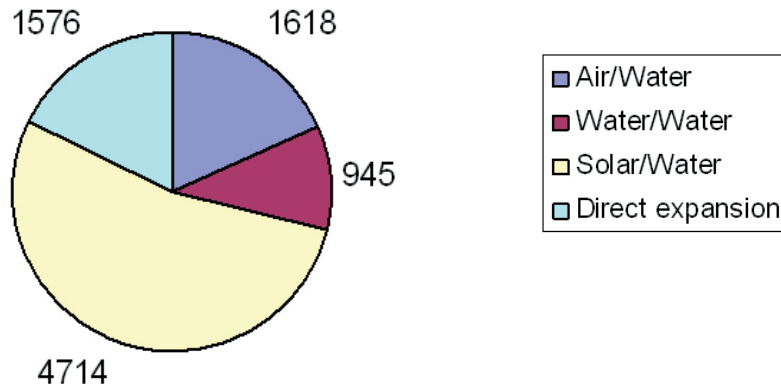

Domestic AC: We hope it never happens

Mitsubishi Electric has raised the question as to whether a growth in domestic air conditioning in the UK is in the best interests of the consumer, the industry, the country and the environment.

Speaking on the first day of the RAC show in Birmingham, Mitsubishi's divisional commercial director Donald Daw said "We need to remove our industry's obsession with the dawn of domestic air conditioning. We hope it never happens and we don't think it's necessary for it to happen."

Claiming that talks had already gone on in private with some other manufacturers, he added "We welcome other manufacturers to discuss this with us. We want an open and honest debate."

The announcement follows the publication of the Stern Report on climate change.

"We are responding to this by announcing our own 100-day plan which will review our operations and highlight ways in which we believe the industry can act to reduce CO₂ emissions, rather than increase them," continued Daw.

Mitsubishi Electric estimates that the splits and VRF sector could account for between 1.6 million to 2.4 million tonnes of CO₂ per annum by 2016.



IEA Heat Pump Programme

Meeting to establish an “Annex 34 - Thermally driven heat pumps”

The meeting was organised by Onno Kleefkens and Peter Schossig, and was held on 8 – 9 March in Freiburg, Germany.

A welcoming address was given by Dr. Volker Wittwer, deputy-director of the Fraunhofer ISE Institute.

The purpose of the meeting was mainly concentrated on giving more attention to the potential of thermally-driven heat pumps for heating and cooling purposes in the built environment. At present, attention is mainly paid to electrically driven heat pumps and chillers.

The activities and focus of the Annex will have to be defined by the participants themselves, keeping in mind that, when starting up an Annex, the results of other Annexes covering the same topics should be used where possible.

The procedure is that after this first meeting a project plan will be developed and formal steps will be taken, preparing a proposal with ‘legal text’, before the next Executive Committee meeting in Paris at the end of May 2007.

Among previous results, Annex 24 has covered the topic of sorption heat pumps. Its results are important for Annex 34, as are the interim results from still-running annexes, such as Annex 29 on Ground Source Heat Pumps and Annex 30 on Heat Pumps for Retrofit, as these cover a part of the market and also provide information on the structure of potential markets.

The Annex 24 conclusion states that the most significant finding is that overall for sorption technology:

task A :Market overview / state of the art

1. Small scale

2. big systems

task B

Performance evaluation

determination of COP, Primary energy consumption comparison

Life cycle analysis

task C

Apparatus technology

Components, Long cycles stability, inert gases, corrosion, material characterisation

task D

System technology

i.e. integration of Heat rejection, efficient burners

task E

Implementation

demonstration, Guidelines Training, dissemination

- There is an inverse relationship between the environmental benefit, and the market pull (and market share), which means that policy measures are deemed necessary in order fully to benefit from the possibilities of these technologies.
- There is a better prospect of improving the thermodynamic efficiency of a single-effect absorption chiller by improving the efficiency of its heat exchangers, rather than by trying to improve the COP with complicated and therefore costly multiple-effect cycle systems.
- Reducing costs (life cycle costs and capital costs) of integrated systems.
- Increasing the efficiency of generators at lower driving temperatures.
- In the residential sector, sorption heat pumps tend to compete mainly with boilers, and so R&D should focus on:
 - Decreasing the size, in order to be able to reduce capital costs.
 - Using the same unit for cooling and heating.
 - Increasing the temperature level, to be able to deliver hot water.

It is important to realise that the promotion of sorption systems should be only for the most suitable applications for each country, which can vary from country to country. This depends mainly on the energy sources and efficiency of electricity production. The main driving force is first costs.

Further conclusions on main technologies that the R&D should focus on:

- Reduction of capital costs, rather than improving COPs.
- For sorption chillers, R&D should focus on:

Both absorption and adsorption systems should be considered for residential and light commercial applications.

Having noted these wise lessons, a new Annex is seen as a necessary step in order further to explore sorption technology.

The participants from each country at the meeting gave a presentation describing state of the art of thermally-driven heat pumps, existing policy and possible interest in participation.



All presentations are included in the proceedings from this meeting.

The objective of the Annex will be to increase the use of thermally-driven heat pumps in order to:

- Reduce the environmental impact of heating and cooling
- Reduce the load on the infrastructure by smoothing and diversifying energy input
- Using waste heat streams, where available

Electric compression heat pumps and chillers are state-of-the-art and/or are becoming more and more popular, increasing the use of electricity and the need for infrastructure security.

Focus in the Annex on use in domestic applications:

- Larger DH systems with cooling
- Small AHP for domestic heating (and cooling)
- Small Abs/Ads Chillers powered by heat from CHP
- Small Abs/Ads Chillers powered by solar heat

As shown in Task 38 in the Implementing Agreement on Solar Heating and Cooling, the last part is already covered by this Task. Collaboration between the Annexes can be established through the Operating Agent, which is Fraunhofer-ISE.

Based upon the outlines given by Peter Schossig, a discussion was held on the contents of the Annex. After the discussion, the proposed structure of the Annex was as shown in the figure above.

The next meeting will be held in Alkmaar (Netherlands) on 11th – 12th September 2007.

For those interested in this project proposal, contact Onno Kleefkens:
 Email: onno.kleefkens@sentern-ovem.nl
 Phone: +31 30 2393 449

Ongoing Annexes

Bold text indicates Operating Agent.

Annex 29 Ground-Source Heat Pumps - Overcoming Market and Technical Barriers	29	AT, CA, JP, NO, SE, US
Annex 30 Retrofit heat pumps for buildings	30	DE, FR, NL
Annex 31 Advanced modelling and tools for analysis of energy use in supermarkets.	31	CA, DE, SE, US
Annex 32 Economical heating and cooling systems for low-energy houses.	32	CA, CH, DE, NL, SE, US, JP, AT, NO
Annex 33 Compact Heat Exchangers In Heat Pumping Equipment	33	UK, SE, US, JP

IEA Heat Pump Programme participating countries: Austria (AT), Canada (CA), France (FR), Germany (DE), Japan (JP), The Netherlands (NL), Norway (NO), Sweden (SE), Switzerland (CH), United Kingdom (UK), United States (US). All countries are members of the IEA Heat Pump Centre (HPC). Sweden is Operating Agent of the HPC.



Industrial high-temperature heat pumps for wood drying

Vasile Minea, Canada

Canadian sawmills traditionally deliver 72 million m³ of resinous lumber per year. About 2% are dried using low-temperature heat pumps and the rest through other technologies using bark-, natural gas- or oil-fired boilers as primary energy sources. However, such products are well suited to high-temperature drying. Two hybrid (electricity/fossil) industrial-scale high-temperature heat pump prototypes for resinous lumber drying have been developed and investigated in Canada. Several improvements have been achieved in terms of working fluid selection, refrigerant flow control, system operating stability, dehumidifying capacity control and optimum drying schedules. The thermodynamic operation and specific energy performances of high-temperature drying heat pumps have finally reached all expected targets.

Introduction

A solution allowing electrically-driven heat pumps to be effective for resinous wood drying would be to use them in combination with fossil energy sources at high temperatures to provide optimum dehumidification speeds and energy savings. The merits of such dryers include lower energy consumption for each unit of water removed, accurate control of drying conditions and enhanced product quality. Their limitations generally concern the need for regular maintenance (filters, refrigerant charges), the risk of refrigerant leaks and higher initial capital costs compared to conventional drying systems. In the 80s, the Canadian wood drying industry promoted dehumidifying concepts, but the performance of such systems was often disappointing due to control problems, inadequate dehumidifying capacity and inappropriate kiln structures. The reliability of the systems was often low, and equipment suppliers did not provide enough information on the actual performance of their systems. Moreover, the early 90s environmental issues imposed the replacement of traditional high-temperature CFC refrigerants, and many R&D projects were delayed. Recently, more environment-friendly

refrigerants have been developed. A few years ago, a North American heat pump driers manufacturer, a Canadian lumber sawmill and Hydro-Québec put together their expertise and know-how in order to develop new high-temperature heat pumps. Hydro-Québec's Research Institute has actively contributed to the development and in-field testing of two industrial-scale prototypes (Minea, 2004).

System configuration

The first two industrial heat pump prototypes contain basic refrigeration components adapted for reliable operation at high temperatures and pressures (Photograph 1). Their compressors, evaporators, variable speed blowers and electric/electronic controls are located inside a plant room adjacent to the dryer enclosure (Figure 1). As a system-specific feature, the refrigerating condensers are remote-type and installed inside the kiln (Lewis, 2003). Designed for industrial processes, the open, belt-driven reciprocating compressors are provided with oil pumps, pressure relief valves and crankcase heaters. The refrigerant (HFC-236fa), a non-toxic and non-flammable fluid,

readily available on the market, has a relatively high critical temperature compared to the highest process temperature (ASHRAE Handbook Fundamentals, 2005). The saturation vapour pressure at the highest design temperature is not so high as to impose design limitations on the system. Previous studies have shown that this refrigerant has cooling capacities up to 20% higher than the best old CFC high-temperature refrigerants (Kasachki, 1994). Micro-processor-based temperature and process controllers displaying setting points and actual process temperatures modulate electronic stepping motor-controlled expansion valves. The 354-m³ industrial-scale wood drier (Photograph 2) includes forced air ventilation with a central six-bladed fan placed above a false ceiling. This fan provides optimum and uniform air flow velocities at the wood stack outlets by reversing its rotation direction at every two or three hours. Because of these rotation changes, all the represented thermodynamic parameters periodically vary in time at the same frequency. To avoid air implosion risks, three air vents open when the central fan changes its rotation direction, and also when the dry-bulb temperature in the dryer exceeds the setting



point. An oil-fired boiler with 82 % annual thermal efficiency supplies high-pressure steam for preheating the dryer, back-up heating for dehumidification cycles with high-temperature heat pumps and for spraying purposes. The boiler burns oil with specific (inferior) calorific value of 10.8 kWh/L at a Canadian market price of C\$ 0.4/L(2004). Steam heating coils (1 500 kW of thermal capacity), vertically installed at the dryer upper side, dissipate steam energy through the wood stacks. In winter, regular dryer heat losses and air leakages technically lead to interior dry-bulb temperatures of maximum 120 °C. About 100 bundles of wood enter the drier enclosure on two parallel train rails.



Photograph 1 – View of one of high-temperature heat pump prototypes

Drying process and schedules

Humidity in white spruce and balsam fir exists as free (liquid or vapour) and linked (hygroscopic) water. In practice, it is accepted that the fibre saturation point occurs at 30 % of resinous lumber moisture content (dry basis). Humidity migration through the wood fiber is driven by affinity and capillarity (adhesion/cohesion) forces, vapour and moisture content gradients and diffusion. The dehumidifying rate is governed by the capacity of the ambient air to absorb humidity, and depends on the temperature and relative air and wood dryness. Before each dehumidifying cycle, 6 to 8-hour preheating steps at a minimum 93.3 °C dry-bulb temperature are necessary. The aim is to destroy the micro-organisms responsible for discolouring the sapwood. When the heat pump starts up (drying step 1), the moisture content first linearly decreases with time, a process followed by a non-linear decrease until the wood boards reach an equilibrium state. The thermal conditions of each drying step with white spruce (generally, easy to dry) or balsam fir (harder to dry) are established by predetermined time-based schedules, depending on the actual moisture contents and wood board dimensions as specified in the Eastern Canada index for wood dry-

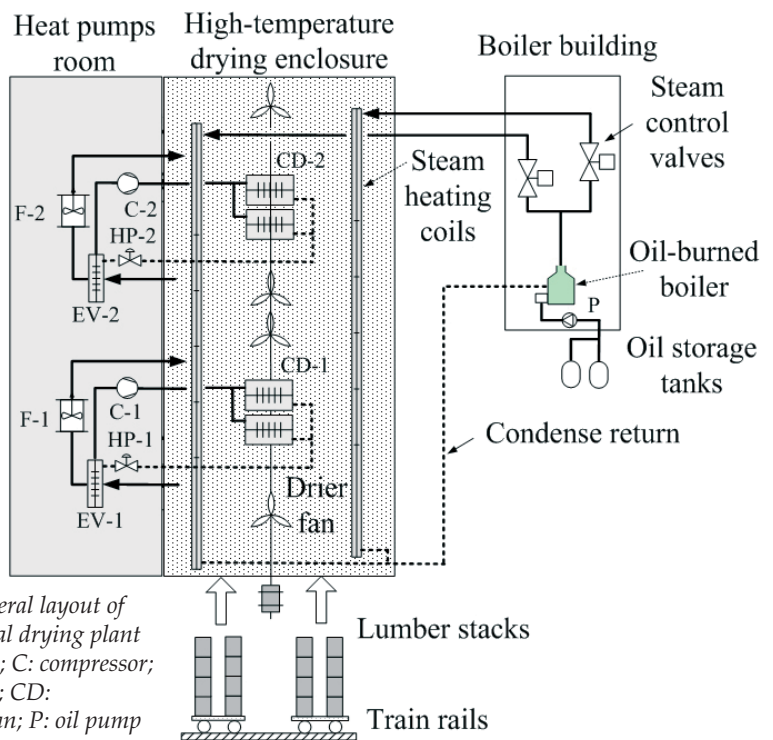

Figure 1 – General layout of the experimental drying plant
HP: heat pump; C: compressor; EV: evaporator; CD: condenser; F: fan; P: oil pump



Photograph 2 –View of the experimental wood dryer

ing (Cech & Pfaff, 2000). The control strategy that has been developed allows both heat pump compressors to shut down when the actual dryer wet-bulb temperature reaches its setting point. After a time delay, and only if the wet-bulb temperature exceeds the presetting set point and a minimum suction pressure is detected, both compressors are simultaneously allowed to restart. If, during the dehumidification drying steps, the dryer actual dry-bulb temperature is lower than its setting point, steam control valves gradually open according to a time-based strategy and close when the setting point is recovered. If the drier actual dry-bulb temperature is slightly higher than its setting point, the air vents open to evacuate the excess heat to the atmosphere.

Operating parameters

More than 250 industrial drying tests were performed with white spruce and balsam fir from Eastern Canada. With white spruce, the dehumidification drying cycles with high-temperature heat pumps lasted around 61 hours. The compressors' electrical power inputs generally varied from 70 kW at the beginning to 60 kW at the end of each drying cycle (Figure 2), while the optimum compression ratios averaged 4 to maximum 5 (Minea, 2004). At the end of drying cycles, the heat pump compressors have sometimes cycled on/off when the actual air dryer wet-bulb temperatures dropped below their setting values. To limit or avoid a high number of compressors shutdowns, the slope of the dryer air wet-bulb temperature was strictly controlled without affecting the predetermined temperature depressions and/or final quality of the dried wood (Figure 3). The compressor discharge temperatures were always about 20 °C to 25 °C higher than the kiln actual dry-bulb temperatures, and up to 8 °C refrigerant liquid sub-cooling amounts were provided.

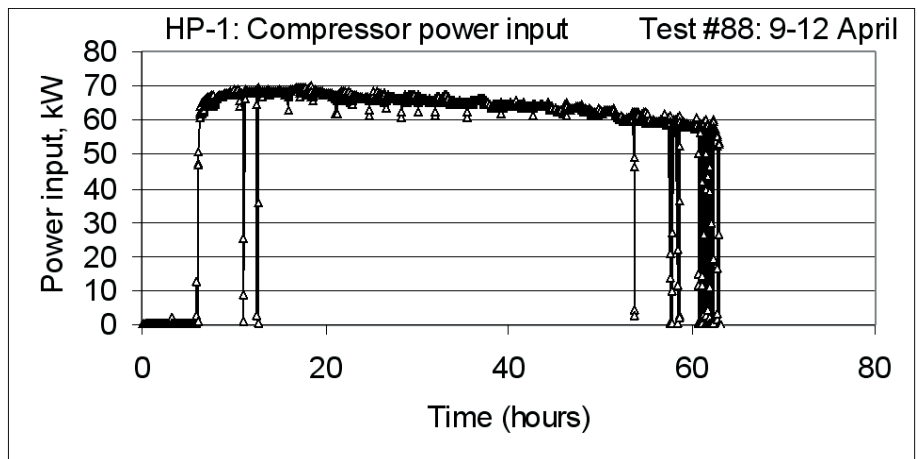

Figure 2 – Compressor electrical power input – HP-1 (test #88)

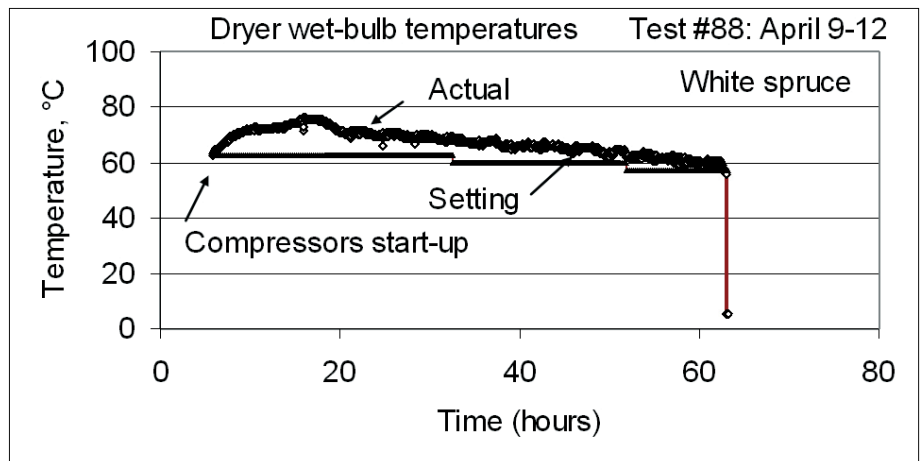

Figure 3 – Dryer setting and actual wet-bulb temperatures (test #88)

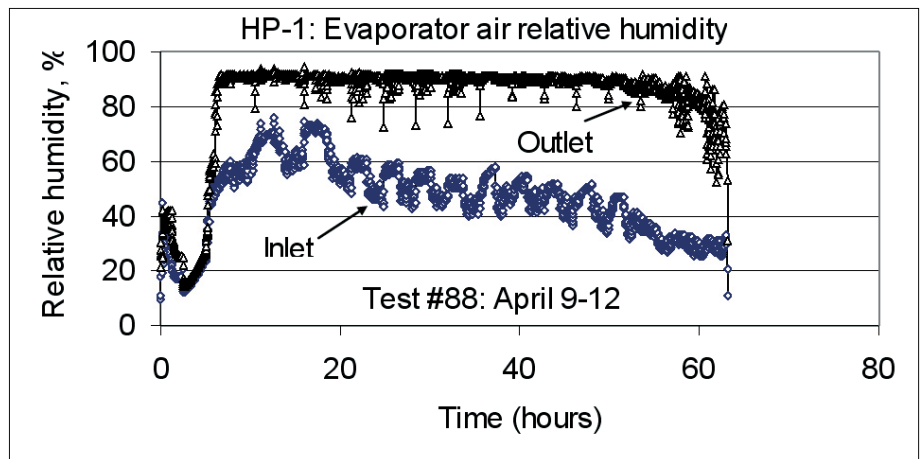

Figure 4 – Air relative humidity entering and leaving the HP-1 evaporator (test #88).

Energy performances

Table 1 brings together the main energy performances of three representative dehumidification cycles with high-temperature heat pump prototypes. The drying time to obtain white spruce with final moisture contents of 17% to 19% averaged 2.5 days (61 to 61.3 hours), while for balsam fir it averaged 6.3 days (151.4 hours). The heat pump average coefficients of performance (COP), defined as the useful thermal power output (W) divided by the electrical power input (W), varied from 4.6 at the beginning to 3.0 at the end of dehumidifying cycles. The total rates of condensed water extraction varied from 263 kgwater/hour to 313 kgwater/hour with white spruce, and about 179 kgwater/hour with balsam fir. These values do not include 90 kgwater/hour (estimated) venting losses, but estimate 5% of condensed water losses by natural evaporation inside the heat pump cabinets and on plant room walls and equipment. The maximum water removal rate of both high-temperature heat pumps reached 19 109 L/cycle with white spruce and 27 081 L/cycle with balsam fir, representing 74 % of the total moisture removed from the wood stacks. About 26 % represent water lost by natural evaporation, condensation and dryer water vapour leakages.

Figure 6 represents, as an example, a typical cumulative water extraction curve of heat pump #1 (test #88). The modified Specific Moisture Extraction Rate (MSMER), defined here as the amount of water extracted by heat pumps (kg) divided by the total electrical energy input (compressors and blowers), expressed in kWh, varied from 1.54 kgwater/kWh (balsam fir) to 2.52 kgwater/kWh (white spruce). These parameters do not include preheating or dryer central fan energy consumptions, nor venting moisture losses. These very favourable performance parameters generally depend on the maximum dryer air temperature and humidity, the evaporator and condenser operat-

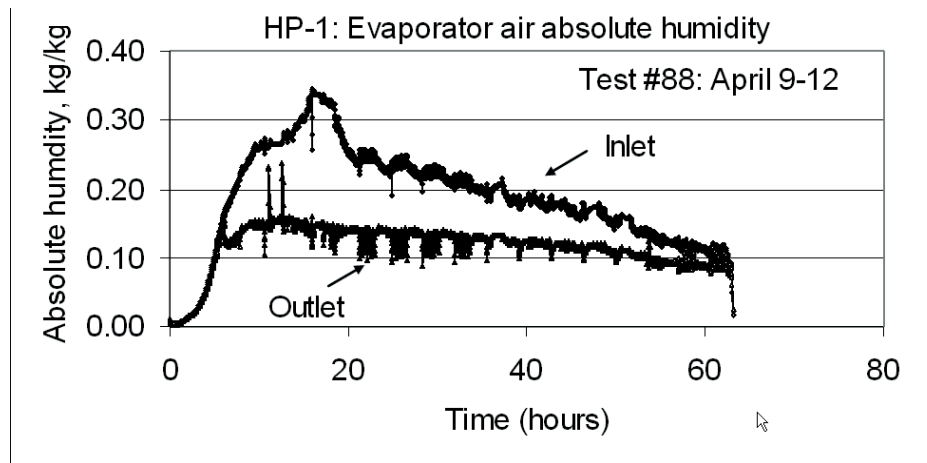

Figure 5 – Air absolute humidity entering and leaving the HP-1 evaporator (test #88)

Table 1 – Performances of three drying cycles with high-temperature heat pump prototypes

Test number	-	#70	#88	#176
Parameter	Unit	-	-	-
Timber species	-	White spruce	White spruce	Balsam fir
Board dimensions (cm x cm x m)	-	5.1x10.1x2.74	5.1x7.62x3	5.1x7.62x3
Duration of drying cycle (hours) (excluding pre-heating steps)	HP-1	61.00	61.3	151.4
	HP-2	61.00	61.3	151.4
Average compressor power input (kW)	HP-1	65.12	63.36	61.0
	HP-2	62.78	58.50	57.14
Compressor energy consumption (kWh)	HP-1	3,972	3,884	9,235.4
	HP-2	3,830	3,586	8,651.0
Heat pump blower energy consumption (kWh)	HP-1	13.42	16.6	28.7
	HP-2	14.03	39.5	107.5
Heat pump TOTAL energy consumption (compressor & blower) (kWh)	-	7 829.5	7 526.1	18 020
Condensed water extraction (Litres)	HP-1	9,454	8,263	13,550
	HP-2	9,655	8,478	13,531
TOTAL water condensed (Litres)	-	19 109	16 741	27 081
Final wood average moisture content (%)	-	17.2	20.6	20.7
Average cycle COP* (-)	HP-1	4.23	4.6	3.46
	HP-2	3.70	4.07	3.00
Cycle MSMER** (kgwater/kWhC)	HP-1	2.38	2.13	1.46
	HP-2	2.52	2.36	1.54

HP: high-temperature heat pump; COP: coefficient of performance; MSMER: modified specific moisture extraction rate (based on compressor and blower energy consumptions); C: compressor



ing temperatures and the overall efficiency of heat pump cycles.

The compressors and blowers of both heat pump prototypes assumed 52% of the total electrical energy consumptions, while the dryer's central fan consumed 48% during the whole drying cycles (Figure 7). It can be noted that the specific drying energy costs are sensitive to the primary energy prices. During the performance tests, the ratio of the hydroelectricity price (C\$0.06/kWh) to the market oil price (C\$0.037/kWh) averaged 1.75 (2004). If, for example, the oil price increased by 75 % and the electricity price by 25 %, the specific drying energy cost would increase by approximately 65 % (Figure 8).

Compared to the specific costs of traditional Canadian oil-based heating resinous wood dryers (18 to 21 C\$/M p.m.p./year [1 M p.m.p. = 1000 p.m.p.; 1 p.m.p.: represents a piece of wood one inch thick, one foot wide and one foot long], excluding the main work and maintenance costs), the specific drying costs of dryers with high-temperature heat pumps and back-up heating with steam generated by oil-fired boilers average 11 to 12 C\$/M p.m.p./year. This performance represents a reduction of 39 % to 43 % in total annual energy costs (fuel and electricity). The annual oil consumption is generally reduced by at least 50 % compared to conventional oil-fired wood dryers. For an industrial-scale 354-m³ resinous wood dryer with 100 drying cycles per year, this represents about 300 000 L/year in oil consumption reduction, equivalent to 887 760 kg of CO₂ emissions reduction. At the same time, the electrical energy consumption will increase by 944 500 kWh/year (heat pump's compressors and blowers, and dryer fans), equivalent to 1 153 kg of CO₂ emissions per year in the province of Quebec (where 98% of the energy is hydroelectric and the indirect emission factor is 0.00122 kg of CO₂-equivalent per kWh reduction). Consequently, net CO₂ emissions would amount to about 886 607 kg CO₂/year per 354-m³ dryer. With, for example, only 25 new installations per year of such dryers in Québec, the total reduction in greenhouse emissions

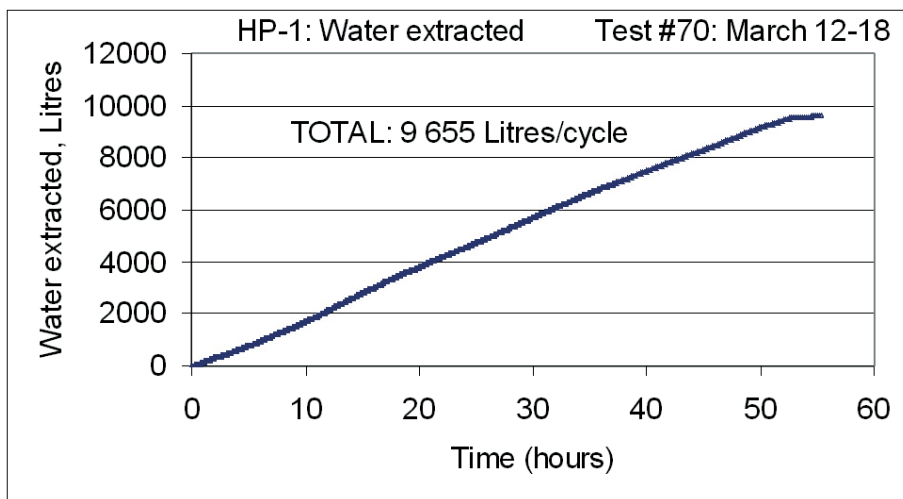

Figure 6 – Cumulative condensed water extraction curve with HP-1 (test #88)

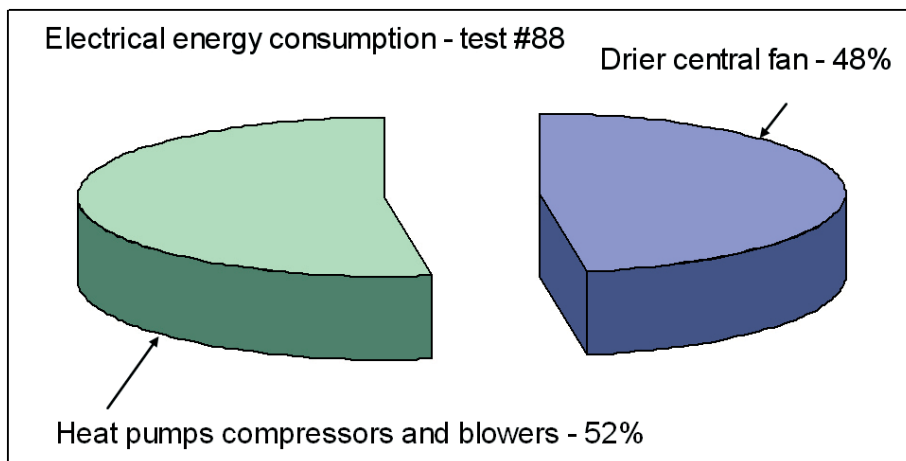

Figure 7 – Share of the total electrical energy consumption (test #88)

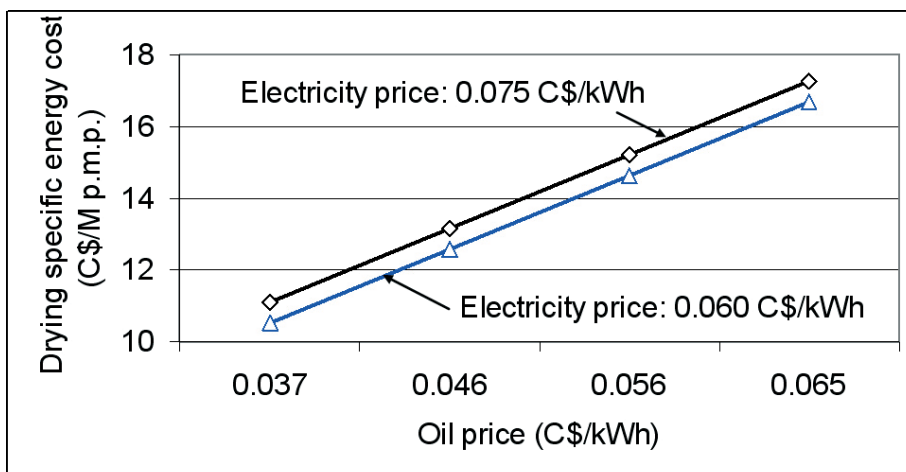

Figure 8 – Sensitivity of drying specific energy costs against primary energy prices
C\$: Canadian dollars; 1 M p.m.p. = 2.36 m³

would be 22 165 tons/year. For the rest of Canada, the specific annual reductions of CO₂ emissions will be less significant, because the indirect emission factors are much higher, varying from 0.13964 (Ontario) to 0.82638 (Saskatchewan) and 0.92527 (Alberta) kg of CO₂ emission/kWh reduction.

System reliability

The development of high-temperature drying heat pumps first aimed at ensuring operational stability of all thermodynamic parameters, testing the reliability of compressors and other major components, and establishing the behaviour of new refrigerant/oil mixtures. The industrial-scale dryer has operated in "extreme" temperature, humidity and corrosion conditions, and sometimes exhibited feedback phenomena that do not occur in traditional forced-air-heated lumber dryers. However, during the first 3 500 hours of continuous operation, the high-temperature refrigerant proved to be thermally stable and chemically inert at the highest temperatures occurring in the system. A first lubricant chemical analysis also indicated that there were no problems with the oil breaking down or failing, and that it showed adequate viscosity and chemical stability, as well as a good miscibility with the high-temperature refrigerant.

Further developments

The future R&D challenges in the field of drying high-temperature heat pumps aim at developing simple and comprehensible design tools and a best-practice guide to match the dryer capacity to the heat pump dehumidification capacity. It is necessary further to optimize the drying schedules, develop new control strategies and select advanced components (for example, a variable-speed dryer central fan) and materials in order to prevent frequent failures or premature corrosion. Better insulated and well maintained dryers are also necessary to obtain drying temperatures higher than 100

°C in the cold Canadian climate, as well as reducing the drying time of resinous species by up to 25 % and the total energy consumption by up to 30 % per drying cycle. Cost-effective and simple techniques for condensed water treatment have also to be developed. It is finally expected to help Canadian equipment suppliers to promote technology and develop appropriate market strategies.

Conclusions

As a clean energy technology compared to traditional heat-and-vent driers, high-temperature heat pump dehumidifiers offer interesting benefits for drying resinous timber. Relatively high average specific moisture extraction rates (2.52 kgwater/kWhC with white spruce and 1.54 kgwater/kWhC with balsam fir) and interesting coefficients of performance (3 to 4.6) were obtained. The new refrigerant/lubricant mixture proved to have good compatibility and chemical stability at condensing temperatures below 100 °C. Even the Canadian wood industry is today adapting its market strategy in relatively difficult economic conditions, the future seems encouraging because the energy savings and reduction of greenhouse gas emissions can contribute to sustainable technological and economical developments.

References

- [1] ASHRAE Handbook – Fundamentals (2005), SI Edition
- [2] Cech, M.J; Pfaff, F. (2000), Operator Wood Drier Handbook for East of Canada, edited by Forintek Corp., Canada's Eastern Forester Products Laboratory
- [3] Kasachki, G.S. et al. (1994), Investigation of HFC-236ea and HFC-236fa as CFC-114 Replacements in High-Temperature Heat Pumps, CFC's: The Day After, Padua, Italy
- [4] Lewis, D. (2003), High temperature dehumidification systems, US Patent
- [5] Minea, V. (2004), Heat Pumps for Wood Drying – New Developments and Preliminary Results, Proceedings of the 14th Inter-

national Drying Symposium, Sao Paulo, Brazil, August 22–25, 2004, Volume B, pp. 892 – 899.

Vasile Minea

Hydro-Québec research Institute, Laboratoire des technologies de l'énergie (LTE)
600, avenue de la Montagne, G9N 7N5, Canada

minea.vasile@lte.ireq.ca

+819-539-1400 (1507)

+819-539-1409



Application of Ammonia Heat Pumps in Norway

Jørn Stene, SINTEF Energy Research, Norway

The use of naturally occurring and ecologically safe substances as working fluids in heat pumps represents an environmental friendly and long-term solution to the problems of HFCs. The most important natural working fluids include ammonia, hydrocarbons and carbon dioxide. This article discusses the main characteristics of ammonia heat pumps, and describes the market development for this energy-efficient technology in Norway.

Introduction

Ammonia (NH₃, R717) is the best-proven alternative among the natural working fluids, since it has been extensively used in industrial refrigerating plants for more than a century. However, it is a toxic fluid, and the strict standards and regulations for the construction and use of ammonia refrigerating and heat pump systems have hampered its use in many countries. In Norway, ammonia has become a commonly used working fluid for medium- and large-scale heat pump systems (>200 kW), due to its favourable environmental and thermophysical properties.

Characteristics of ammonia heat pump systems

Since hydrous ammonia corrodes copper and zinc, structural steel and aluminium are the most commonly used materials in ammonia heat pump systems.

Ammonia has a very high specific enthalpy of evaporation [kJ/kg] compared to R407C and R134a, which are the most commonly used working fluids in Norwegian non-residential heat pump systems. This results in a low mass flow rate, which reduces the required dimensions of pipelines and valves by typically 30 to 50 % for the same drop in saturation temperature. Another advantage is that, despite the low vapour density of ammonia, its volumetric heating capacity [kJ/m³] is relatively high. At

-5 °C/50 °C evaporation/condensing temperature, the necessary compressor volumes for R407C and R134a heat pump systems will be roughly respectively 30 % and 90 % higher than that of an ammonia system.

Under identical operating conditions, ammonia heat pumps have higher energy efficiencies than R407C and R134a systems. For a theoretical single-stage heat pump cycle operating with -5 °C/50 °C evaporation/condensing temperature, isentropic/adiabatic compression and no suction superheat or sub-cooling, the COP of the ammonia cycle is about 7 % and 11 % higher than that of the R134a and R407C cycles. The difference will be even greater in real systems, due to the favourable thermophysical properties of ammonia. This includes a steeper saturation temperature curve, superior heat transfer properties and high compressor efficiencies. At low pressure ratios, ammonia compressors are considerably better than HFC compressors, although relatively similar compressor efficiencies are attained at high pressure ratios [1].

The discharge gas temperature of ammonia is considerably higher than that of the HFCs. Various measures are of current interest in order to ensure reliable and energy-efficient operation of the compressor, including low-temperature heat distribution systems, high-temperature heat sources, larger surfaces for the evaporator and condenser, flooded evaporator operation, short and well-insulated suction lines, water-

cooled cylinder heads for reciprocating compressors, two-stage plant design at compression ratios above 5 to 6, and desuperheaters for hot water production.

Another disadvantage with ammonia heat pumps is the limited supply water temperature of approx. 48 °C from the condenser when using standard 25-bar equipment [3]. If the heat pump is supplying heat to a high-temperature hydronic heat distribution system (e.g. 80/60 °C or 70/50 °C at DOT), the return temperature may be higher than the maximum supply temperature from the condenser over longer periods of time. This will reduce the annual heat supply from the heat pump and so also the SPF of the system. If 25-bar ammonia heat pumps are to be used for heating and cooling of buildings, it is of crucial importance that the hydronic heat distribution is designed for a relatively low return temperature. This can be achieved by serial connection of radiators and heating coils in the ventilation system combined with volume flow control of the primary water circuit.

By using two-stage system design with a 40-bar compressor and condenser in the second stage, the maximum supply water temperature can be increased to about 68 °C. Two-stage operation will boost the COP by as much as 20 to 40 %, but the costs are 80 to 100 % higher than that of single-stage systems. The additional cost for a single-stage 40-bar system is about 15 to 25 % [3].



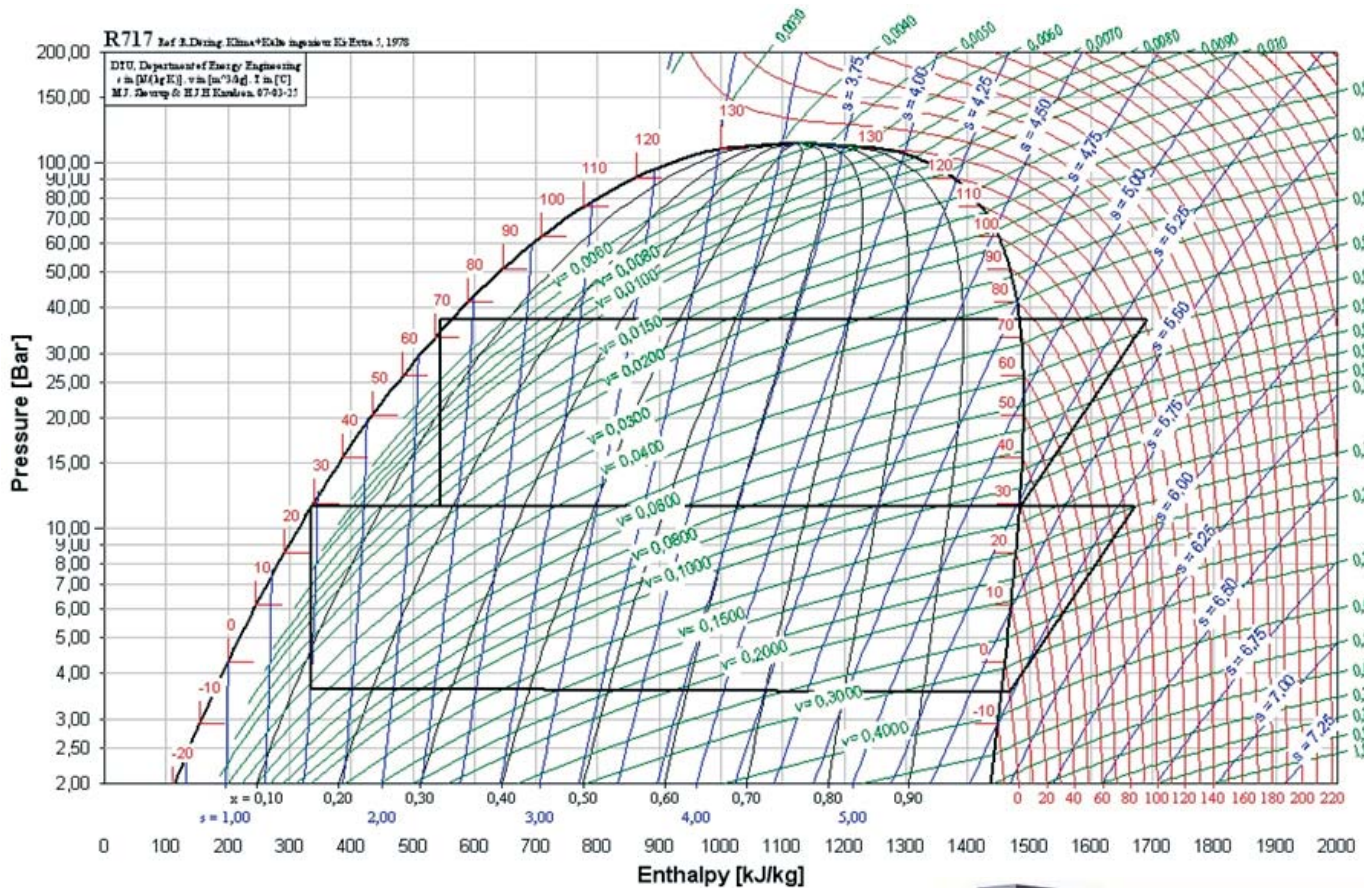

Example of an energy-efficient two-stage ammonia heat pump cycle at $-5\text{ }^{\circ}\text{C}$ and $75\text{ }^{\circ}\text{C}$ evaporation and condensing temperatures. The isentropic compressor efficiency is 0.75 [5].

Due to the considerable variations in the heating/cooling loads and temperature requirements in the heat distribution systems in buildings, ammonia heat pump systems should be designed for high energy efficiency at part-load operation and varying condensing temperatures. This implies the use of several heat pump units equipped with reciprocating compressors or inverter-controlled screw compressors with variable volume ratios. Conventional screw compressors are unsuitable due to low energy efficiency at part-load operation and varying temperature rise. Nor are centrifugal compressors of current interest in ammonia systems, since the low molar mass (17.03) would require multiple-stage compression, about six times as many as for R134a.

Toxic Fluid – Safety Measures

The main arguments against the installation of ammonia heat pumps in densely populated areas are related to the consequences of possible uncontrolled ammonia release. Ammonia



Examples of open reciprocating and screw compressors for ammonia.



is a toxic fluid with a pungent odour. The pungent odour may cause panic, but it also eases the detection of leaks. The Immediate Danger for Life and Health (IDLH) value for ammonia is 500 ppm, and the lowest fatal concentration reported is 5000 ppm [1]. Since the Lower Explosion Limit and auto-ignition temperature are as high as 15 % by volume and 651 °C respectively, ammonia is classified as toxic but moderately flammable in most refrigeration standards. In order to ensure maximum safety in ammonia heat pump plants, a number of mandatory/optional safety measures must/may be implemented:

- Low-charge ammonia units
- Gas-tight and fire-proof machinery room with self-closing doors if the room located inside the building, or in a container on the roof of the building
- Leak detectors activating visual/audible alarms etc.
- Fail-safe emergency ventilation system – constant under-pressure around the ammonia units
- Ammonia scrubber for efficient absorption of ammonia vapour in the exhaust ventilation air

Market – installation examples

Several hundred ammonia heat pumps have been installed in Norway since the early 1990s. Most installations are in larger buildings (200 kW to 2 MW) and in district heating and cooling systems (700 kW to 8 MW). There are also a considerable number of ammonia heat pumps in ice rink systems, industry (super-charge units, drying units) and fish farming plants. About 25 of the ammonia heat pump installations are two-stage 40-bar systems. The Directorate for Public Construction and Property in Norway (Statsbygg) prefers to install ammonia heat pumps, since ammonia is an environmentally friendly working fluid with excellent thermophysical properties.

Ammonia heat pump in a research centre (1994)

A 900 kW ammonia heat pump system for space heating, space cooling and hot water heating was installed in 1994 at the Statoil Research Centre in Trondheim. The heating and cooling demands at design conditions for the 28 000 m² building are 1.5 and 1.35 MW respectively. Sea water from 60 meters depth is used as the heat source.

son for the poor performance is that the gas-fired boilers cover the entire heating load at low ambient temperatures, since the return temperature in the heat distribution system at these operating conditions is higher than the maximum supply temperature of 48 °C from the heat pump units. As a consequence, the heat pump system supplies less than 80% of the total an-

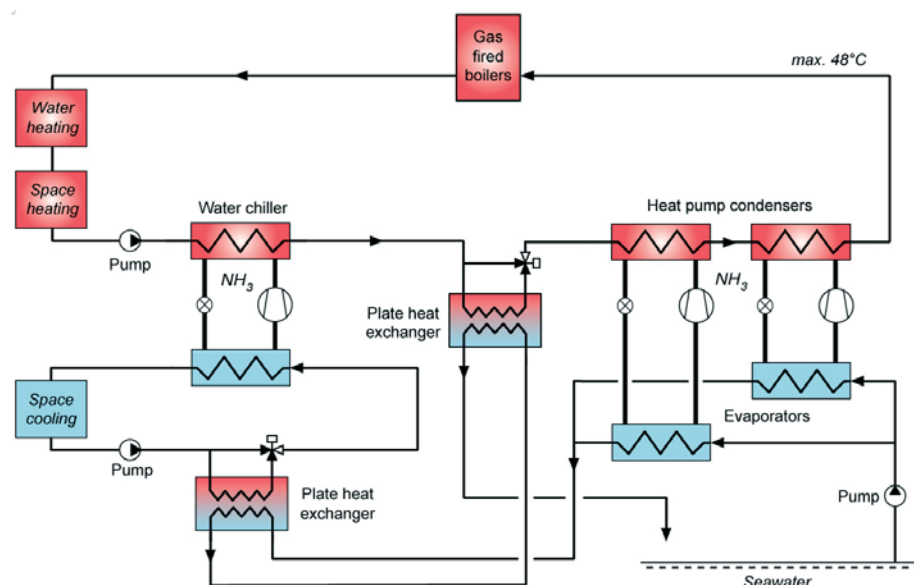

Schematic diagram of the 900 kW ammonia heat pump system at the Statoil Research Centre

The heat pump comprises two identical single-stage heat pump units with two 25-bar six cylinder reciprocating compressors, a titanium plate heat exchanger as the evaporator and a two-pass shell-and-tube condenser. The ammonia charge is about 0.2 kg per kW of heating capacity. Auxiliary heating and back-up is provided by gas-fired boilers. Since the machinery room is located inside the building on the ground floor, the room is gas-tight with self-closing doors, and a two-stage ventilation system maintains constant under-pressure around the units. Other safety measures include leak detectors, an alarm system and a tailor-made ammonia scrubber. The scrubber is installed in the ventilation duct, and reduces the ammonia concentration in the exhaust air to a maximum of 50 ppm in the case of a major leakage.

Although the COP of the heat pump units is about 4.5 at design conditions, the SPF of the bivalent heating system is less than 2.5. The main rea-

nual heat load of the building. This problem could have been solved by using a two-stage 40 bar heat pump system – or even better, by designing the hydronic heating system for a lower return temperature.

Ammonia heat pump in a district heating and cooling system (1998) Norway's largest ammonia chiller and heat pump system (CHPS) was installed at Oslo Airport Gardermoen in 1998 [2]. The maximum heating and cooling capacities of the system are 7.5 MW and 6.0 MW respectively, and the system utilizes the vast groundwater aquifer in the area as a thermal energy storage system (ATES). The ATES system consists of nine cold wells and nine warm wells. In winter mode, groundwater from the warm wells is used as the heat source for the CHPS, and the return water is supplied to the cold wells. In summer mode, the groundwater from the cold wells is used for pre-cooling, and then returned to the warm wells.

The two single-stage ammonia heat pump units are equipped with shell-and-tube evaporators and condensers, although plate heat exchangers could have substantially reduced the ammonia charge. Seven 8- and 16-cylinder reciprocating compressors are used in order to achieve high efficiency at part-load operation. The measured overall SPF for the CHPS in heating and cooling mode is about 5.5.

The total ammonia charge of the heat pump system is 2500 kg. Due to the toxicity of the fluid and the considerable charge quantity, the gas-tight plant room is located about 1 km from the terminal building and equipped with leak detectors, a fail-safe emergency ventilation system and a sprinkler system.

Ammonia heat pump system in a hospital (2008)

The new district general hospital in Akershus (SiA) is currently under construction. The buildings will have a total floor area of about 160 000 m², and the hospital will be fully operative from October 2008. A combined ammonia chiller and heat pump system (CHPS) will supply heating and cooling to the buildings, and the system will be connected to the largest underground thermal energy storage system (UTES) in Europe, comprising 350 two hundred metre deep boreholes in bedrock [4].

The CHPS from York Refrigeration will consist of three single-stage screw-compressor units with slide valve control and variable volume ratio, and one single-stage unit with two large reciprocating compressors. Each unit has a maximum cooling capacity of roughly 2 MW.

The CHPS is designed for a maximum cooling load of about 7.7 MW. The heating capacity of the system at design outdoor temperature (DOT) is about 5 MW. The units will supply condenser heat to a low-temperature circuit at a maximum supply temperature of 52 °C (space heating, heating of swimming pools etc.), and desuperheat to a high-temperature circuit at a maximum supply temperature

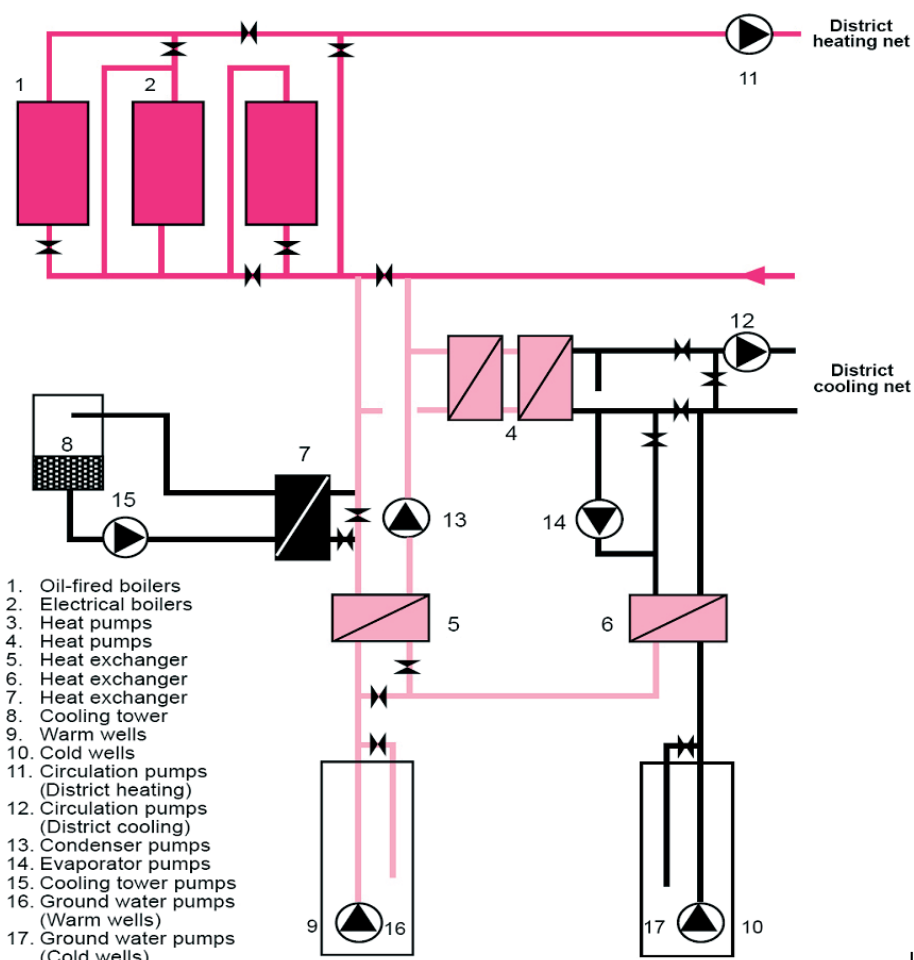

Schematic diagram of the 7.5 MW ammonia heat pump system at Oslo Airport, Gardermoen

of 75 °C (hot water heating). The heat pump will supply about 80% of the total annual heating demand of the hospital, and oil-fired boilers will be used as peak load.

References

[1] Stene, J., 1998: IEA Annex 22: Final Report – Guidelines for Design and Operation of Compression Heat Pump, Air Conditioning and Refrigerating Systems with Natural Working Fluids. IEA HPP Report No. HPP-AN22-4. ISBN 90-73741-31-9.

[2] Eggen, G., Vangsnes, G., 2005 Heat pump for district cooling and heating at Oslo, Airport Gardermoen. Proc. from the 8th IEA Heat Pump Conference, May 2005. Las Vegas, USA.

[3] Information from York Refrigeration, Norway

[4] Information from Sweco Grøner AS, Norway

[5] CoolPack, 2000. Simulation programme for heat pumps and refrigerating plants developed at the Technical University of Denmark (freeware). <http://www.et.web.mek.dtu.dk/Coolpack/UK/>

Dr.ing. Jørn Stene
 SINTEF Energy Research – Division
 Energy Processes
 NO-7465 Trondheim, NORWAY
 Phone: +47 73 59 16 42
 Fax: +47 73 59 39 50
 E-mail: Jorn.Stene@energy.sintef.no

Thermally Powered Heat Pump/Chiller Sets New Efficiency Standard

Donald C. Erickson, USA

Conventional thermally powered water heaters are 80 to 95% efficient. The new thermally powered heat pump (TPHP) reported herein is over 140% efficient. In addition, the cold end of this TPHP produces useful chilling. The amount of energy-free chilling is equal to the amount of heat pumping. The combination of the world's highest hot water heating efficiency, plus energy-free chilling, all from a single economic appliance, makes this a very significant development.

This article explains how the TPHP works, making use of an ammonia-water absorption cycle. It also presents operating results from an ongoing full-scale demonstration of TPHP at a poultry-processing plant, where a thermal (steam) input of 530 kW produces 320 kW chilled water and 850 kW hot water. It operates on a 20/5 basis automatically and unattended. The savings in both natural gas and electricity add up to over \$110K per year. The simple payback is approximately 1.8 years.

Introduction

A great deal of heating is done at low temperature, i.e. at a temperature only modestly above ambient temperature. Examples include hot water heating (50 to 75°C); space heating (20-25°C); and drying (40 to 90°C). A surprising amount of energy is consumed for these applications – nearly 20 quads per year in the United States alone. (One quad equals 1 quadrillion BTU).

Even more surprising is how inefficient the conventional low temperature heating processes are. Heater manufacturers claim efficiencies of 80 to 95% (fuel-fired) or 98+% (electric or steam powered). However those are “First Law” efficiencies. The true measure of thermodynamic efficiency is the Second Law efficiency. When fuel with a 1600°C adiabatic flame temperature is used to heat water to 55°C, the Second Law efficiency is extremely low – approximately 23%. With electric resistance heating, the Second Law efficiency drops to about 10%. In other words, an ideal reversible cycle using that same electrical energy would heat ten times more hot water than the resistance heater.

One consequence of the extreme low efficiency exhibited by conventional low temperature (LT) water heaters is that the door is thereby opened to a variety of other technologies, such as combined heat and power (CHP) or solar thermal. The low efficiency and resultant high fuel cost justifies the use of those costlier water heating technologies because they consume less fuel.

Unfortunately, the currently available alternatives for more efficient LT heating (CHP and solar thermal) are so costly and/or complex that they have made limited progress toward reducing the fuel wasted in this sector. The paybacks are at best in the four-year vicinity, and frequently longer.

What is needed is a more cost effective and less complicated method of improving the efficiency and economics of low temperature heating. That is what the Thermally Powered Heat Pump/Chiller (TPHP/C) accomplishes. Two field demonstrations of the TPHP/C have now been conducted, to verify the claimed performance and economy. The first, now in operation for four years, is small in capacity (20 kW chilling)

and has limited operating hours (30 hours per week with lots of starts and stops) (references 1 and 2). The second, reported herein, has 350 kW chilling capacity and operates 100 hours per week. The first demonstration verified long term operability, but doesn't have enough operating hours to achieve good economics. The larger demonstration, reported here, has a two-year payback even at the demonstration stage, without any economic subsidy. (References 3 and 4).

TPHP/C Characteristics

In the operation of this heat pump, heat enters the cold end of the TPHP/C, thus producing chilling, and then exits the warm end, thus producing warm water. Being “thermally powered” signifies that higher temperature input heat is supplied as the motive force, and that heat also exits as hot water. Figure 1 illustrates these relationships. One unit of high temperature heat is input to the TPHP/C, which is the motive force to produce 0.6 units of chilling. Both the one unit and the 0.6 units exit the TPHP/C as hot water. Hence the net



effect is 0.6 units of chilling and 1.6 units of water heating from a heat input of one unit.

Figure 2 shows how an actual thermodynamic cycle (in this case an absorption cycle, plotted on pressure-temperature coordinates) accomplishes the above result. Conceptually there are many other ways this thermodynamic result can be accomplished, but we have found this particular approach to be the most practical. High temperature heat is input to the cycle at the generator; chilling is produced at the evaporator; and heat is rejected from the cycle both at the condenser and absorber, thus producing hot water. This (or any) absorption cycle, which produces 0.6 units of chilling from one unit of input heat, is said to have a Coefficient of Performance (COP) of 0.6.

Figure 3 translates the thermodynamic diagram of Figure 2 into an actual flow sheet, showing components and interconnecting piping.

Field demonstration

The sequence of preparing poultry for market is regulated by the U.S. Department of Agriculture, and includes a scalding step using 57°C hot water, followed in short order by chilling with 0.5°C chilled water. The plant hosting this demonstration processes 50,000 birds per hour for 16 hours each day. This requires a continuous flow of at least 785 liters per minute (lpm) hot water and 785 lpm chilled water. The hot water is produced from 630 kPa (80-psig) steam from natural gas-fired boilers, and the chilled water is produced from an ammonia vapor compression refrigeration plant powered by electricity. At current utility rates (90¢ per therm gas and 9¢ per kWh electric) (one therm equals 100 kBTU equals 35 kWh), the plant spends \$454K per year on natural gas to make the hot water, and over \$100K per year on electricity for the refrigeration to make chilled water.

The TPHP/C produces both chilled water and heat pumped hot water

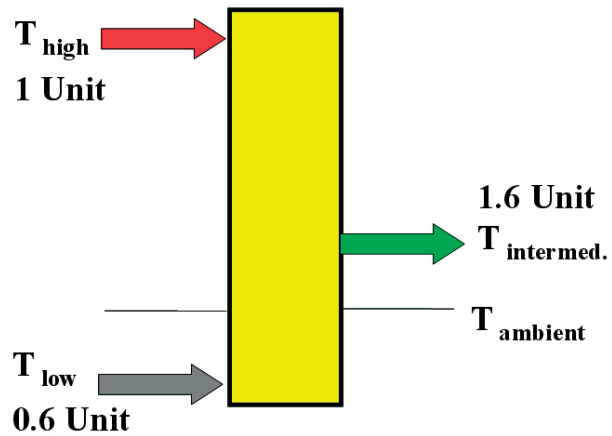

Figure 1. Tritherm Thermally Powered Heat Pump/Chiller

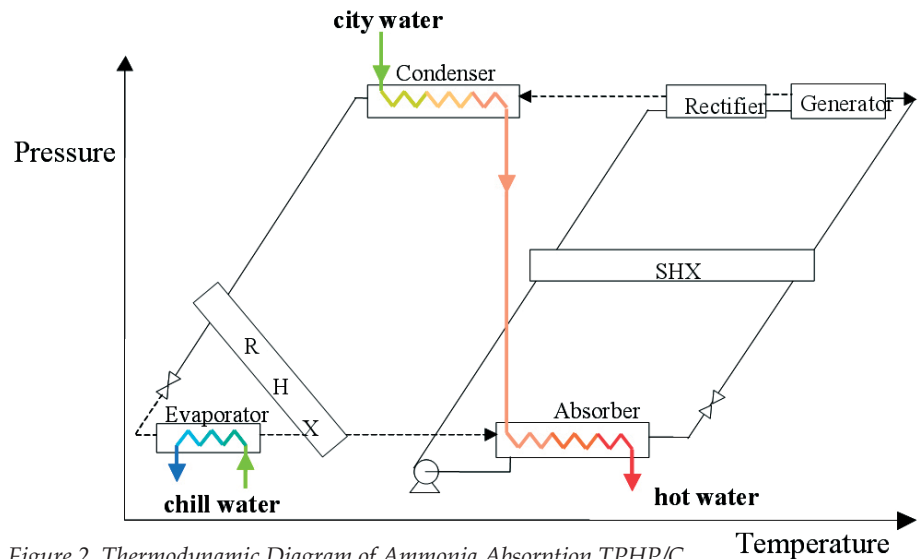

Figure 2. Thermodynamic Diagram of Ammonia Absorption TPHP/C

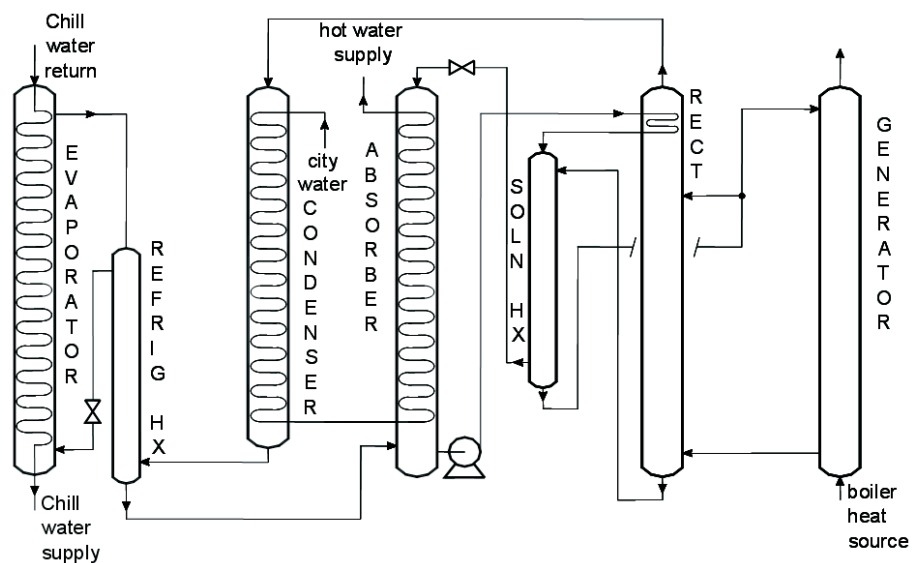

Figure 3. TPHP/C Flowsheet



from a single heat source. It is powered by the same steam which otherwise would make the hot water, but with two important differences. First, instead of the 98% efficiency of a steam hot water heater, the TPHP/C achieves 156% efficiency in converting steam to hot water, due to the heat pumping action. Second, the chilled water is produced as a by-product of the hot water production, eliminating the need for a separate chiller or any additional energy to supply the chilled water.

Table 1 illustrates this particular demand for hot water and chilled water (processing 50,000 chickens per hour), and how the TPHP/C reduces the natural gas requirement from 97 therms per hour to 61, and reduces the electric demand from 242 kW to 12. Table 2 tabulates the corresponding savings. The utility bill is reduced by \$276K per year, i.e. to less than half the current cost. Based upon the typical installed cost for an 875 kW chilling capacity TPHP/C of \$500K, the payback is 1.8 years. There is a corresponding large reduction in CO2 emissions – 1,800 tons per year reduction.

Field demonstration results

In view of this promising economic projection, a demonstration was commenced at no cost to the host site. A unit was designed to supply 350 kW of chilling and 930 kW of hot water simultaneously, from 580 kW of 630 kPa steam. It was installed at a poultry-processing plant, where it pre-chills the cold water for the continuous chiller, and pre-heats the hot water for the continuous scalding. Connections were made to the steam service, the condensate return system, city water supply, chill water supply, and hot water supply. The system was automated by installing level switches in the existing hot water storage tank and chill water storage tank. A full signal from either tank stops the TPHP/C, and both tanks must be below full for it to start. It was also found necessary to install a water booster pump on the

- Continuous scalding and chiller: 50,000 birds/hour and 0.94 liter/bird = 785 liters/minute
- Hot water heating requirement: 785 lpm from 16°C to 57°C = 2,258 kW (97 therm/hr)
- Chill water refrigeration requirement: 785 lpm from 16°C to 0.5°C = 242 tons (displaces 242 kWe)
- THERMOSORBER:

Table 1. Poultry Processing Example (TS250)

• HOURLY SAVINGS		
– 36 therms @ \$0.90/therm	\$32.40/hour	
– 230 kWh @ \$0.09/kWh	\$20.70/hour	
	\$53.10/hour	
• ANNUAL SAVINGS (for 20/5 operation)		
– 5200 HOURS @ \$53.10	\$276,120/year	
• INSTALLED COST	\$500,000	
• PAYBACK	1.8 Years	
• AVOIDED CO2 EMISSIONS	1800 tons/year	

Table 2. Economics of Poultry Processing Application (TS250)



- Delivers up to 350 kW chilling and 930 kW heat pumped hot water from 580 kW steam.
- Saves 30% of water heating and 90% of chilling energy.
- 5°C chill water and 58°C hot water
- Automated, unattended operation, 20 hours/5 days per week

Figure 4. TPHP/C for Large Poultry Processor

city water supply since the supply pressure was highly variable. The respective chill water and hot water flow rates are the primary means of controlling chill water temperature and hot water temperature.

This demonstration TPHP/C operates during poultry processing (about 16 hours per day, five days per week) and also during the first four hours of clean-in-place, when there is a high demand for hot water and the chill water storage tank is being re-filled. For the first several months it was manually started and stopped each day. Then that was automated with level switches on the storage tanks. The next four months of operation were fully automatic.

As might be expected with any demonstration project, a few occurrences required manual intervention. The most troublesome was caused by a leaking solenoid valve. Two shutdown solenoid valves are provided, which close upon shutdown to keep the cycle fluids in the proper locations to facilitate the subsequent startup. One valve had a slight internal leak, which allowed the pump receiver level to slowly decrease. This was not a problem during the daily shutdown, which only lasted about four hours. However during the forty-hour weekend shutdown, the receiver level declined to where the pump lost suction and the TPHP/C would not start. This required that a bypass hose be manually connected to return the solution to the receiver. The immediate problem was fixed by replacing the solenoid valve. For the longer-term fix, recognizing that solenoids do sometimes leak, the TPHP/C will be made more fault-tolerant by installing a larger pump receiver and hard piping the bypass connection.

Table 3 provides snapshots of about a dozen discrete times where operating data was recorded and the cycle performance was analyzed. Since this demonstration TPHP/C only supplies about 40% of the total demand of this plant, the chill water and hot water flow rates are maintained at

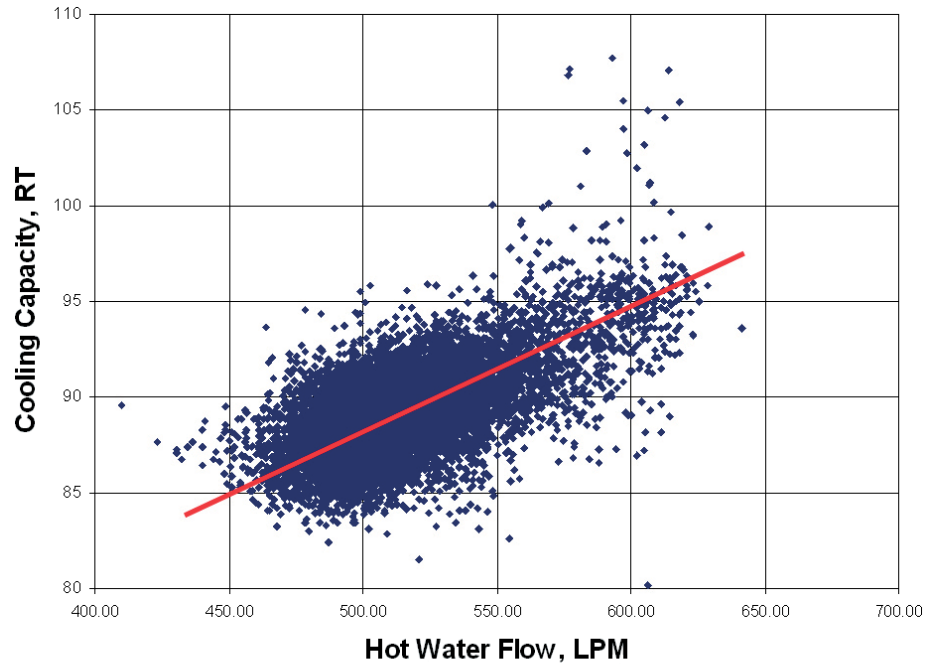

Figure 5. Water Flow Effect on TPHP/C Capacity



Figure 6. 175 kW ThermoSorber (TS50)

Date		040706	040806a	040806b	040806c	040806d	053106	060106	060607	061306	061406	080106	080206
Temp [C]	Steam	154.1	154.7	158.9	157.5	158.4	156.1	157.2	158.3	158.9	157.2	159.3	158.3
	Condensate	150.8	154.0	156.8	156.0	157.0	155.0	154.4	155.0	158.3	147.8	158.2	157.2
	City water	21.1	20.6	21.0	20.9	20.5	20.6	20.6	21.1	20.6	20.6	21.1	21.2
	Chill Water	10.8	10.1	10.1	10.9	10.6	11.1	11.1	11.1	10.6	11.1	11.0	11.5
	Hot Water	48.1	48.3	50.3	49.7	50.2	49.4	48.9	48.3	49.4	47.8	46.2	46.6
Flow Rate [lpm]	Sol-Pump	65.3	62.1	63.2	59.8	58.7	61.3	62.8	61.7	62.1	63.6	66.6	66.6
	Chill Water	444.7	444.7	444.7	444.7	444.7	450.4	450.4	458.0	446.6	465.6	469.3	469.3
	Hot Water	462.9	468.2	454.2	433.8	412.6	416.4	425.4	474.3	437.9	456.8	520.4	498.9
	Condensate	17.0	17.8	18.5	17.4	17.0	16.7	17.0	18.2	17.8	17.0	18.2	17.8
Pressure [bar]	HP	15.5	15.6	15.7	15.6	15.9	14.8	14.8	14.9	14.8	14.8	15.9	15.8
	LP	4.7	4.4	4.5	4.5	4.7	4.9	4.9	4.9	4.7	4.9	4.7	4.8
Performance	RT	90.6	92.6	96.0	87.7	87.2	84.1	84.1	90.5	88.3	86.9	93.8	89.7
	COP	0.586	0.570	0.576	0.557	0.567	0.551	0.548	0.553	0.548	0.550	0.574	0.560
Heat Duty [kW]	COND	358.6	382.0	394.5	372.6	365.3	360.3	358.4	389.7	382.6	370.5	379.4	365.0
	RHX	30.7	35.0	35.6	33.8	35.9	29.7	29.6	31.6	30.7	26.1	28.5	30.8
	EVAP	318.7	325.5	337.6	308.5	306.8	295.7	295.7	318.3	310.5	305.6	329.8	315.3
	HT-ABS	324.8	327.4	329.1	305.0	294.3	321.5	341.8	379.2	363.5	357.7	340.9	366.6
	LT-ABS	181.2	189.1	201.4	186.4	189.8	153.5	136.5	127.1	132.3	134.7	186.6	149.5
	SHX	105.8	114.5	115.7	107.9	104.0	118.3	121.6	120.9	125.5	123.4	130.7	128.8
	GHX	76.0	77.6	88.7	73.5	75.9	53.5	56.4	69.4	59.0	59.7	52.2	60.6
	GEN	544.2	571.5	585.9	554.1	541.2	536.8	539.2	575.9	566.1	555.5	575.0	563.5

Table 3. TPHP/C Demonstration Unit Results

high values. This increases the heat pumping capacity, to above 315 kW. Figure 5 illustrates that effect.

When both water flows were slowed to achieve higher temperature lift (e.g. 5°C chill water and 55°C hot water), the capacity declined to about 230 kW.

Other applications

This appliance finds application anywhere that heating temperatures in the range of 45°C to 70°C, plus some chilling, are required. Examples include:

- domestic hot water heating
- space heating
- commercial, industrial drying
- food processing

The TPHP/C is being developed with the brand name “ThermoSorber”. Standard design ThermoSorbers are available ranging from 240 kW water heating (90 kW chilling) to 1800 kW water heating (700 kW chilling). They can be powered by steam, natural gas, propane, fuel oil, solar heat, or waste heat (e.g. engine or boiler exhaust heat). The

TS50 model shown in Figure 6 (175 kW chilling) will save a medium-size hospital or hotel over \$100,000 per year in energy utilities. The installed cost is about \$150,000. This size ThermoSorber reduces CO2 emissions by 395 tons per year. Custom units are available for any capacity. It is also planned to scale the ThermoSorber down to residential size.

The United States Department of Energy National Energy Technology Laboratory sponsored early development of the ThermoSorber. Two field demonstrations have been underwritten by the California Energy Commission and Pacific Gas & Electric Company

Conclusions

This demonstration has verified the record-setting efficiency of the TPHP/C. It has also shown that a steam-fired (or fuel-fired) TPHP/C can have exceptionally good economics with a reasonable utilization factor – about 62% utilization in this case.

References

1. “Prototype Commercial Hot Water Gas Heat Pump (CHWGHP) - Design and Performance” Erickson, D.C., Anand, G., Panchal, C.B., Mattingly, M. ASHRAE Transactions, 2002. Vol. 108 Pt. 1. pp. 792-798, January 2002
2. “Gas Fired Heat Pump for Heating and Refrigeration in Food and Beverage Industry” California Energy Commission Public Interest Energy Research Program, CEC500-5-094, April 2005
3. Mannapperuma, Jatal D., 2006, Watt Poultry USA, Energy-Saving Heat Pump Produces Scalding, Chilling Water, p. 18-20, December”. “Thermally Driven Heat Pump for Hot Water Heating and Chilling”

Donald C. Erickson
 Energy Concepts Co.
 Emerging Technologies
 Summit, Long Beach, CA, October 27, 2006



Coabsorbent heat pumps for the future

Mihail-Dan N. Staicovici

Based on the coabsorbent cycles, recently introduced by the author, a particular new technology can be developed for extremely efficient and feasible heat pumping applications. The paper presents model results of residential and district ammonia/water heating applications for coabsorbent hybrid and absorption heat pumps, supplied by different winter and summer heating and cooling pairs of sources. Among these applications, author's proposal of coupling the coabsorbent heat pumping plants with thermal power stations, is one of the most important, for effective district heating (besides thermofication) and/or cooling, and power plant global efficiency increase up to 90 percent.

Introduction

The coabsorbent cycles, recently introduced in previous works, (Staicovici, 2006a – 2007c), lay down the basis of a new emerging technology with high potential in efficient and feasible heat pumping applications. This paper presents model results of some winter and summer coabsorbent applications for hybrid and absorption heat pumps, operated by the ammonia/water, which this excellent working combination qualities of are best put in opera with coabsorbent cycles only.

Basic, nontruncated heating and cooling coabsorbent cycles

For the sake of completeness, the basic ideas of the coabsorbent cycles are remembered first. So far, the absorbent administration in an absorption cycle, including two or more subcycles (interconnected by mass and/or heat transfer), bases on a common, known practice that, in short, could be expressed by "a separate absorbent flow in each individual subcycle". In a previous work, a recent research begun by the author (Staicovici, 2006a) is proposing a new type of absorption cycles, with a different absorbent administration, and named "with co-absorbent", or simpler, coabsorbent cycles. In this way, all condensation and resorption cycle problems (e.g. reduced solubility field, rectification need, ab-

sorbent migration, or cycle complexity increase with COP improvement) could be avoided, if coabsorbent cycle were used. The coabsorbent cycle is built up by joining the resorption cycle subcycles along a common isostere ($x=1$), so that the opposed pair processes, of generation and resorption, and of absorption and desorption, are isobar and in mass (vapor) and heat exchange, and the subcycles separate absorbents have a common point " x_m " (mixing point), where are mixing and cyclic regenerate the absorbent mean concentration. By joining upon temperature decrease two cooling + heating type subcycles, it is obtained a nontruncated cooling coabsorbent cycle, Figure 1a, and by joining upon temperature decrease two heating + cooling type subcycles, it is obtained a nontruncated heating (heat transformer) coabsorbent cycle, Figure 1b, (Staicovici, 2006a). The nontruncated coabsorbent cycles are new, individual basic thermodynamic absorption cycles, and have particular flow and heat properties. Each coabsorbent

cycle must be separately thermally analyzed. However, their COP is generally favoured, as compared to that of the condensation and resorption ones, because they completely eliminate vapour rectification, and have gliding heat exchange with sources. Additionally, due to the large concentration intervals which the opposite absorption/desorption processes are operating with their temperatures are frequently overlapping, so that the GAX effect can be used. Also, internal recovery heat exchange of solution/solution and solution/gas types is mandatory for COP increase. Starting from the nontruncated coabsorbent cycles, countless coabsorbent cycles can be conceived. This is the reason why their selection is mandatory. The simplest coabsorbent cycles are derived by composing the nontruncated and truncated ones (Staicovici, 2006f, 2006g, 2007b). The truncation requires a special technique, (Staicovici, 2006d, 2006g), which enables a better cycle source-task match. The truncated and nontruncated cycles

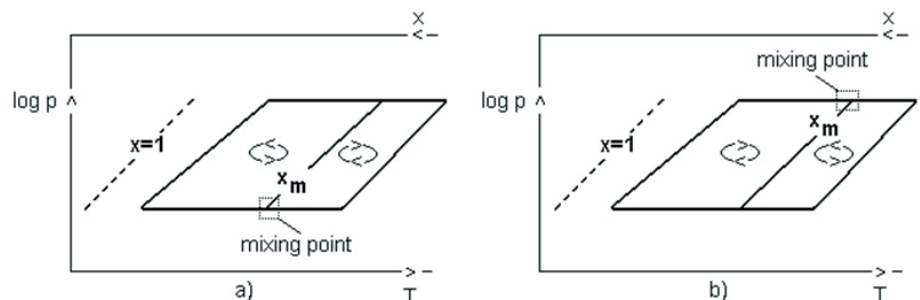

Figure 1. Cooling (a), and heating (b) nontruncated coabsorbent cycles.

are intrinsic related one to each other from the topologic and absorbent flow point of view, and this makes them to behave as fractals, wherefrom, nontruncated coabsorbent cycles are termed cooling and heating fractals, (Staicovici, 2006g).

Coabsorbent heat pumps applications

Next, we shall give a few results of coabsorbent heat pumps applications, having absorption and hybrid operation.

Coabsorbent Cycle Hybrid Heat Pump

We start with the coabsorbent cycle hybrid heat pump, (Staicovici, 2006a, 2006b), Figure 2. The heat pump can work as a hybrid coabsorbent cycle, when the four devices, R, G, A, and D (see Figure 2) are implied, or as a wet resorption hybrid (Osenbrück) cycle, with R and D devices, only. The heat pump COP, $COP_{hp} = q_R / (W_c + W_p)$, was modelled, where q_R , W_c and W_p are the resorber useful heat, the compression and pumping works, respectively. The compression work has been considered adiabatic and was assessed according to (Kirilin, 1985):

$$W_c = (n/(n-1))RT_{G,vap}((p_R/p_G)^{(n-1)/n} - 1)$$

where n , R , $T_{G,vap}$, p_R and p_G hold for adiabatic exponent ($n=1,31$), gas constant, generator vapour mean temperature, resorber and generator pressure, respectively. COP values (mechanical efficiency of 0.9 included), given in Figure 3 against resorber inlet temperature, with ($\Delta T =$ desorber inlet max. temperature-absorber min. temperature=10; 12.5; 15; 17.5; 20, 22.5; 25; 27.5 and 30 C) as parameter, are by 2.5 to 3 times higher than those of the usual vapour compression heat pumps, encouraging its use in medium and large capacity heating applications. Truncation enables to obtain much higher COP values, but at the expense of a gradual complexity and sources capacity increase, leaving the heat pump engineer the freedom to choose an optimum design for a given application.

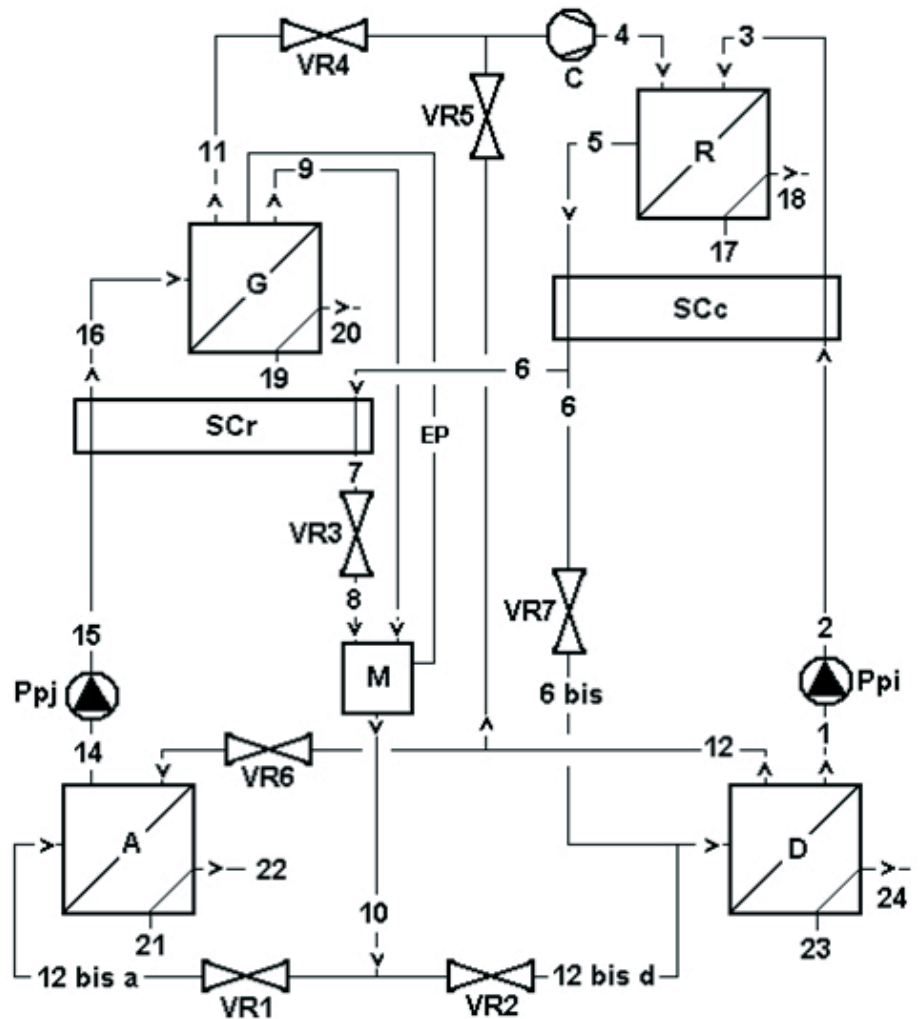

Figure 2. Nontruncated coabsorbent hybrid heat pump (hybrid heating fractal): Resorber (R), Generator (G), Absorber (A), Desorber (D), SC=HE, Mixer, Pump, Compressor, VR=valve.

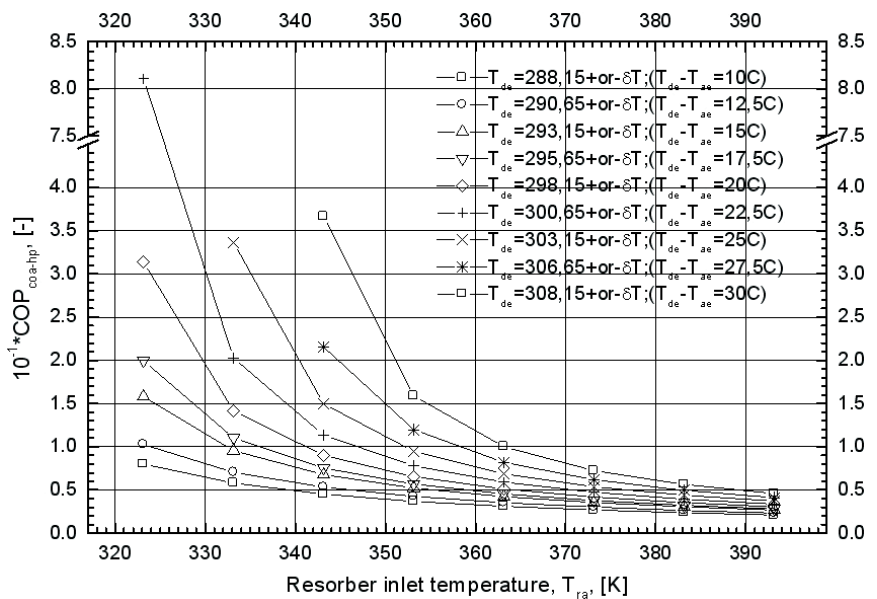

Figure 3. NH_3/H_2O coabsorbent hybrid heat pump COP vs. resorber maximum temperature T_{ra} . Modelling conditions: adiabatical single-stage vapor compression; mechanical efficiency = 0.9; resorber maximum temperature: $T_{ra} = (323.15 \text{ to } 393.15) - \text{or } + \Delta T$, where $\Delta T = 0$ to $10 \text{ } ^\circ\text{C}$; absorber minimum temperature: $T_{de} = 278.15 + \text{or } -$; mixer concentration: $y_{mix} = 0.7$; absorber outlet concentration: $y_{mix} + 0.05$

Coabsorbent Cycle -Thermal Power Plants Coupling For District Heating And Cooling

Thermofication is a very efficient way to deliver heat to district heat systems, sacrificing a small amount of electrical power, only. Due to its high efficiency potential, the coabsorbent cycle technology offers the opportunity to couple the coabsorbent heat pumping plants with thermal power stations for district heating and cooling, increasing the thermal power plant global efficiency, for environment, electrical power producers and heat and cooling transport, distribution and consumption benefit. The technical solution, given in Figure 4, (Staicovici, 2006e, 2006f, 2007b, 2007c), is based in principle on a known heat pump,

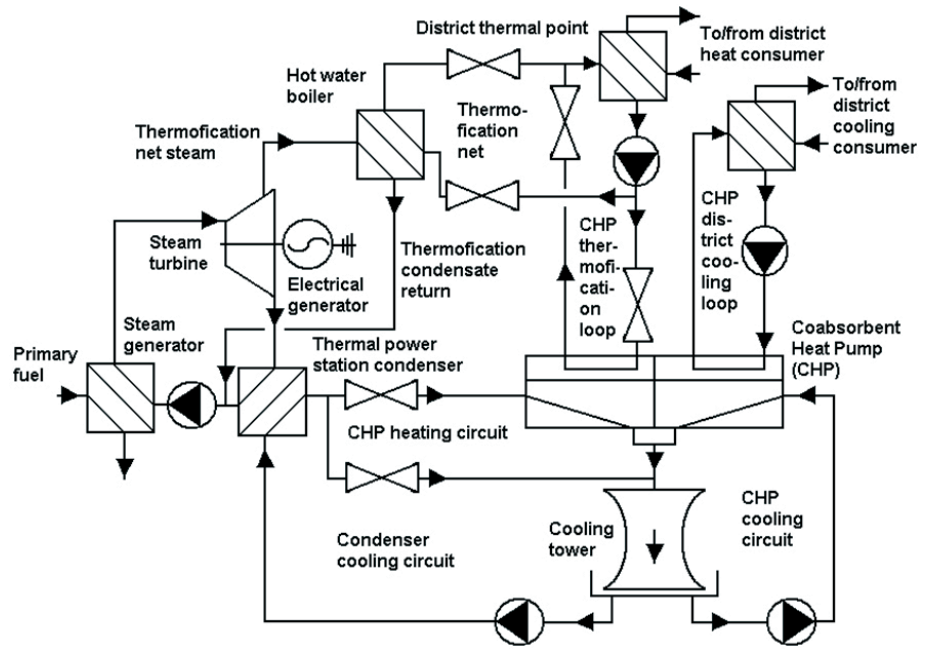

Fig. 4. District heating and/or cooling flow chart using a coabsorbent heat pumping plant-thermal power station coupling.

Table 1. Hybrid heating fractal and truncated heating fractal coabsorbent heat pumps operation data for summer-winter and several (heating + cooling) pairs of sources and useful heat temperatures.

Year period	Heating source / Cooling source		Sources temperatures (C)	Useful heat (task) temperature (C)	Application	Mean heating COP	Capacity (useful heat units / heating source heat units)
				HHF* - THF**			
1	2	3	4	5	6	7	
Winter	Ground	(+5) - (+7)	62 - 62	Residential	3.82 - 5.2***	0.49 - 0.33	
	Ambient air	(-20) - (-4)					
	Underground water	(+12) - (+14)	67 - 67	Residential	4.74 - 208	0.48 - 0.21	
	Ambient air	(-20) - (-4)					
	Thermopower station condenser cooling water	(+40) - (+55)	117 - 117	District	4.68 - 57	0.45 - 0.17	
	Tower cooled water	(+10) - (+15)					
	Thermopower station condenser cooling water	(+40) - (+55)	117 - 132	District	5.69 - 27.5	0.45 - 0.14	
Ocean (sea) water	(+5) - (+8)						
Thermopower station condenser cooling water	(+40) - (+55)	117 - 117	District	15.75 - 180	0.46 - 0.33		
Ambient air	(-20) - (-4)						
Summer	Ambient air, waste heat	(+30) - (+40)	67 - 96	Residential	10.69 - 92.16	0.45 - 0.19	
	Ground	(+5) - (+8)					
	Ambient air, waste heat	(+30) - (+40)	62 - 76	Residential	7.97 - 80.86	0.45 - 0.23	
	Underground water	(+12) - (+14)					
	Solar energy	(+25) - (+35)	67 - 75	Residential	7.3 - 92.65	0.46 - 0.22	
	Ground	(+5) - (+8)					
	Solar energy	(+25) - (+35)	62 -	Residential	7.62 -	0.48 -	
	Underground water	(+12) - (+14)					
	Thermopower station condenser cooling water	(+40) - (+55)	77 - 90	District	8.38 - 55.52	0.47 - 0.24	
	Tower cooled water	(+25) - (+35)					
Thermopower station condenser cooling water	(+40) - (+55)	77 - 122	District	22.77 - 73.93	0.47 - 0.17		
Ocean (sea) water	(+10) - (+20)						



used in condensation turbine power plants (Radenco et al., 1985), which couldn't be effectively applied so far, especially in Romania, because of the low heat pumps COP and power station electrical efficiency. According to author's solution, a fraction of the free low grade condenser heat, at 40 to 55 °C, is powering the coabsorbent plant generation + desorption devices, on one side, and a fraction of the tower cooled condenser cooling water, at 10 to 30 °C, is cooling the absorption coabsorbent plant device, on the other side. In this way, the heat pump is delivering heat at 80-160 °C, extending the thermofication process. Similarly, a coabsorbent hybrid refrigeration plant can be coupled with the thermal power station, Figure 4, in order to deliver most efficient cooling (-60 to +10 °C). The coabsorbent heat pumping plants - thermal power station coupling might increase the global power station efficiency (electrical + heat and/or cooling) to about 90 percent.

3.3. Coabsorbent Heat Pumps Operation COP For Several (Heating+Cooling) Pairs Of Sources

The coabsorbent heat pumps, of hybrid heating fractal and truncated heating fractal type, have been modelled for summer - winter operation, different (heating+cooling) pairs of sources and useful heat temperatures, in case of residential and district heating applications. In our study we used simple to quadruple truncated columns (Staicovici, 2006d). The model input data and results are given in Table 1. Heating and cooling sources and their probable temperature variation range are indicated in columns 2 and 3, respectively. All heating source temperatures are specific to a waste (low grade) heat use. The task temperature, column 4, is differing from the source (resorber inlet (highest) temperature) by $\Delta t = 3C$. Mean heating COP, column 6, show several to hundred times higher values as compared to those of the compression heat pumps for each application. However, heat pumps capacity (last column), defined as (useful heat units / heating source

heat units), indicate that about 1/2 to 1/6 of the heating source becomes useful only, so a designer has to find the heat pump optimal configuration and thermal performance, taking into account sources availability, as well.

Conclusions

This work presents NH₃/H₂O coabsorbent heat pumps applications for different operating conditions. The model heating COP varies between several times and hundred times, as compared to the compression heat pumps COP. However, the higher the COP, the higher the heat pump complexity and sources capacity. Despite these, their high theoretical efficiency strongly recommend coabsorbent heat pumps use in middle and large heating capacity applications, such as district heating, besides thermofication, by coupling them with the condensing turbine thermal power stations.

References

1. Staicovici M.D. 2006a, Coabsorbent cycles, Proc. Gustav Lorentzen Natural Working Fluids International Conference, IIF/IIR: 219-222.
2. Staicovici M.D. 2006b, Heat pump (in Romanian), Romanian patent file deposition No. A /00135 /02.03.2006.
3. Staicovici M.D. 2006c, Coabsorbent hybride cooling plant (in Romanian), Romanian patent file deposition No. A /00588 /24.07.2006.
4. Staicovici M.D. 2006d, Truncated coabsorbent cycle cooling method and application plant (in Romanian), Romanian patent file deposition No. A /00748/26.09.2006.
5. Staicovici M.D. 2006e, Information and cooperation proposals letters sent by the author to the Bucharest Mayorality, RADET, Electrocentrale-Bucharest, and FAPR-Bucharest.
6. Staicovici M.D. 2006f, The coabsorbent cycle technology for heat pumping applications, Proc. UTCB Conference "Confort, Ef-

iciency, Energy Conservation And Environment Protection" (in Romanian), Technical Civil Engineering University of Bucharest (UTCB), 29-30 November, Bucharest, Romania.

7. Staicovici M.D. 2006g, Coabsorbent cycles. Part one: Theory, Sent for publication in the Int. J. of Thermal Sciences.
8. Staicovici M.D. 2007a, Coabsorbent cycles. Part II: Applications. To be sent for publication.
9. Kirilin V.A., Sicev V. and Seindlin A.E. 1985, Thermodynamics (in Romanian), Scientific and Encyclopedic Publishing House, Bucharest, 541 p.
10. Radenco V. et al., 1985, Heat pump installations (in Romanian), Technical Publishing House, Bucharest, 384 p.
11. Staicovici M.D. 2007b, Coabsorbent cycle technology for ammonia/water heat pumping applications, Proc. IIR/IIF Conference "Ammonia Refrigeration Technology for Today and Tomorrow", Ohrid2007, April 19-21, Macedonia.
12. Staicovici M.D. 2007c, Coabsorbent heat pumping method by coupling with a thermal power station and application plant (in Romanian), Romanian patent file deposition No. A /00134 /22.02.2007.



IPCC/TEAP Special Report. Safeguarding the ozone layer and the global climate system: issues related to hydrofluorocarbons and perfluorocarbons.

This report was produced by the Intergovernmental Panel on Climate Change (IPCC) and the Technology and Economic Assessment Panel (TEAP) on the invitation of the UN Framework Convention on Climate Change and the Montreal Protocol. It provides a balanced scientific, technical and policy-related assessment that will assist all concerned in taking decisions when considering alternatives to ozone-depleting substances. The report is published in one full version which can be ordered from Cambridge University Press or downloaded from the IPCC web site. Available from the web site are also a summary for policy makers and a technical summary, both are available in different languages.

More information about this very important report can be found at www.ipcc.ch

Bibliography on CO₂: 2004-2006 references and abstracts

This CD-ROM contains the bibliographical references of over 200 scientific and technical articles on CO₂ and its applications in the fields of refrigeration, air conditioning and heat pumps. The full papers can in many cases be ordered directly from the IIR.

*The bibliography can be ordered from the IIR at www.iifir.org
Price: 16 Euro*

1st international conference on magnetic refrigeration at room temperature

These proceedings contain 39 papers in the field of magnetic refrigeration, covering both materials and systems. Material topics covered are gadolinium and its alloys, manganite materials, thermodynamic models for magnetic materials etc. Systems issues covered are performance and modelling of regenerative room-temperature magnetic refrigeration cycles, optimisation of magnetic refrigerators at room temperature for

air-cooling systems, design and performance aspects, and a reciprocating magnetic refrigerator and much more.

*The bibliography can be ordered from the IIR at www.iifir.org
Price: 35 Euro*

Commercial refrigeration and thermophysical properties and transfer processes of refrigerants

These proceedings contain 134 papers presented at the two conferences held in August 2005. Topics covered are display cabinets, energy simulations, absorption and adsorption, CO₂, refrigerants and secondary refrigerants, control, natural fluids, ice slurries, boiling and evaporation, micro- and minichannels and more.

*The bibliography can be ordered from the IIR at www.iifir.org
Price: 80 Euro*

New publication released by the International Energy Agency:

Climate Policy Uncertainty and Investment Risk

Our climate is changing. This is certain. Less certain, however, is the timing and magnitude of climate change, and the cost of transition to a low-carbon world. Many policies and programmes are therefore still at a formative stage, and policy uncertainty is very high.

This book identifies how climate change policy uncertainty may affect investment behaviour in the power sector. For power companies, where capital stock is intensive and long-lived, those risks rank among the biggest and can create an incentive to delay investment. Our analysis results show that the risk premiums of climate change uncertainty can add 40 % of construction costs of the plant for power investors, and 10 % of price surcharges for electricity end users. Climate Policy Uncertainty and Investment Risk tells what can be done in policy design to reduce these costs.

Energy policies of IEA countries - 2006 review

What are the latest developments in energy policy and markets in the 26 member countries of the International Energy Agency and other key non-member countries such as China, India and Russia? This compilation contains a broad analysis of recent trends and an easily accessible overview of energy policy during the last twelve months.

The overview section of the 2006 edition examines trends in energy markets, including an analysis of energy demand and supply, energy prices and energy-related CO₂ emissions. It highlights key policy trends across member and non-member countries on energy security, energy market reform, climate change mitigation, energy efficiency, renewables and energy R&D. The report contains a special chapter on energy efficiency, which compares the most successful efficiency policies of member countries on the basis of in-depth review findings of the past three years. It also presents the major findings of the World Energy Outlook 2006, key statistical information and brief summaries of major IEA publications released during the past year.

2007

30 May-1 June
European Geothermal Congress
Unterhaching, Germany
www.egc2007.de

8-9 June
Technological innovations in air conditioning and refrigeration industry
XII European Conference
 Milan, Italy
 UNEP, Associazione Tecnici del Freddo, Centro Studi Galileo Industria & Formazione
<http://www.centrogalileo.it/milano/CONGRESSODIMILANO2007english.html>

10-14 June
CLIMA 2007
 9th REHVA World Congress, endorsed by ASHRAE
 Helsinki, Finland
 E-mail: [info @ clima2007.org](mailto:info@clima2007.org)
<http://www.ashrae.org/clima2007>

10-13 June
Energy Efficiency in Motor Driven Systems
 Beijing, China
[eemods07 @ copper.org.cn](mailto:eemods07@copper.org.cn)
<http://www.eemods.cn/>

23 - 27 June
ASHRAE Annual Meeting
 Long Beach, California, USA
<http://www.ashrae.org/>

21 – 26 August
22nd IIR International Congress of Refrigeration (ICR2007)
 Beijing, China
 Contact: Qiu Zhongyue
 Tel: +86 10 6843 4683
 Fax: +86 10 6843 4679
 E-mail: [icr2007 @ car.org.cn](mailto:icr2007@car.org.cn)
<http://www.icr2007.org>
<http://www.iifir.org>

3 – 6 September
10th International Building Performance Simulation Association Conference and Exhibition
 E-mail: [bs2007 @ tsinghua.edu.cn](mailto:bs2007@tsinghua.edu.cn)
<http://www.bs2007.org.cn/>

12 – 14 September
Sustainable building 2007
 Lisbon, Portugal
<http://www.portugalsb07.org/>

17 – 19 September
Fan Noise 2007
 E-mail: [info @ fannoise2007.org](mailto:info@fannoise2007.org)
<http://www.fannoise2007.org/>

16 – 21 September
Sixth International Conference on Enhanced, Compact and Ultra-Compact Heat Exchangers: Science, Engineering and Technology
 Potsdam, Germany

27 – 29 September
28th AVIC Conference
BUILDING LOW ENERGY COOLING AND ADVANCED VENTILATION TECHNOLOGIES IN THE 21ST CENTURY
 Crete Island, Greece
<http://palenc2007.conferences.gr/>

6 - 9 October
HARDI Annual Fall Conference
 Orlando, Florida, USA
<http://www.hardinet.org/>

9 - 10 October
3rd Annual European Energy Policy Conference
 Brussels, Belgium
<http://guest.cvent.com/EVENTS/Info/Summary.aspx?e=455c0ca8-3464-4a45-9181-2c24fb62ff74>

15 - 17 October
ASHRAE's IAQ 2007 - Healthy & Sustainable Buildings
 Baltimore, Maryland, USA
<http://www.ashrae.org/publications/detail/15187>

18 - 19 October
2nd International Conference SOLAR AIR-CONDITIONING
 Tarragona, Costa Dorada, Spain
 Organisation Committee:
 Das Ostbayerische Technologie-Transfer-Institut (OTTI e.V.)
 Regensburg, Germany
 Tel: +49 941 29688-29/-37
 Fax +49 941 29688-17
 E-mail: [gabriele.struthoff-mueller @ otti.de](mailto:gabriele.struthoff-mueller@otti.de)
[britta.haseneder @ otti.de](mailto:britta.haseneder@otti.de)

21 - 25 October
SMACNA Annual Convention
 Las Vegas, Nevada, USA
<http://www.smacna.org/>

28 - 31 October
The 6th International Conference on Indoor Air Quality, Ventilation & Energy Conservation in Buildings - IAQVEC 2007
 Sendai, Japan
[iaqvec2007 @ sabine.pln.archi.tohoku.ac.jp](mailto:iaqvec2007@sabine.pln.archi.tohoku.ac.jp)
www.iaqvec2007.org

7 - 9 November
New Ventures in Freeze-drying
[l.rey @ aerial-crt.com](mailto:l.rey@aerial-crt.com)
 Fax: +33 (0)3 8819 1520
<http://www.aerial-crt.com>

In the next Issue
Mobile Air Conditioning (MAC)

Volume 25 - No. 2/2007





International Energy Agency

The International Energy Agency (IEA) was established in 1974 within the framework of the Organisation for Economic Co-operation and Development (OECD) to implement an International Energy Programme. A basic aim of the IEA is to foster co-operation among its participating countries, to increase energy security through energy conservation, development of alternative energy sources, new energy technology and research and development.

IEA Heat Pump Programme

International collaboration for energy efficient heating, refrigeration and air-conditioning

Vision

The Programme is the foremost world-wide source of independent information & expertise on heat pump, refrigeration and air-conditioning systems for buildings, commerce and industry. Its international collaborative activities to improve energy efficiency and minimise adverse environmental impact are highly valued by stakeholders.

Mission

The Programme serves the needs of policy makers, national and international energy & environmental agencies, utilities, manufacturers, designers & researchers. It also works through national agencies to influence installers and end-users. The Programme develops and disseminates factual, balanced information to achieve environmental and energy efficiency benefit through deployment of appropriate high quality heat pump, refrigeration & air-conditioning technologies.

IEA Heat Pump Centre

A central role within the programme is played by the IEA Heat Pump Centre (HPC). The HPC contributes to the general aim of the IEA Heat Pump Programme, through information exchange and promotion. In the member countries (see right), activities are coordinated by National Teams. For further information on HPC products and activities, or for general enquiries on heat pumps and the IEA Heat Pump Programme, contact your National Team or the address below.

The IEA Heat Pump Centre is operated by



SP Technical Research
Institute of Sweden

IEA Heat Pump Centre
SP Swedish National Testing
and Research Institute
P.O. Box 857
SE-501 15 Borås
Sweden
Tel: +46 10 516 50 00
Fax: +46 33 13 19 79
E-mail: hpc@heatpumpcentre.org
Internet: <http://www.heatpumpcentre.org>



National team contacts

AUSTRIA

Prof. Hermann Halozan
Technical University of Graz
Innfeldgasse 25
A-8010 Graz
Tel.: +43-316-8737303
Fax: +43-316-8737305
Email: halozan@tugraz.at

CANADA

Dr Sophie Hosatte
Natural Resources Canada
CETC – Varennes
1615 Bd Lionel Boulet
P.O. Box 4800
Varennes
J3X 1S6 Québec
Tel.: +1 450 652 5331
E-mail: sophie.hosatte@nrcan.gc.ca

FRANCE

Mr Etienne Merlin
ADEME/DIAE
27 rue Louis Vicat
75737 Paris Cedex 15
Tel.: +33 1 47 65 21 01
E-mail: Etienne.Merlin@ademe.fr

GERMANY

Prof. Dr.-Ing. Dr. h.c. Horst Kruse
Informationszentrum Wärmepumpen und
Kältetechnik - IZW e.V.
c/o FKW GmbH
D-30167 Hannover
Tel. +49-(0)511-16 74 75-0
Fax +49-(0)511-16 74 75-25
E-mail: email@izw-online.de

Prof. Dr.-Ing. H.J. Laue - Alternate
Informationszentrum Wärmepumpen und
Kältetechnik - IZW e.V.
Unterreut 6
D-76 135 Karlsruhe
Tel.: +49 721 9862 856
Fax: +49 721 9862 857
E-mail: IZWeV.Laue@t-online.de

JAPAN

Mr Takeshi Yoshii
HPTCJ
Kakigara-cho, F Building (6F)
1-28-5 Nihonbashi, Kakigara-cho
Chuo-ku, Tokyo 103-0014
Tel.: +81-3-5643 2404
Fax: +81-3-5641 4501
Email: yoshii@hptcj.or.jp

NETHERLANDS

Mr Onno Kleefkens
SenterNovem
P.O. Box 8242
3503 RE Utrecht
Tel.: +31-30-2393449
Fax: +31-30-2316491
Email: o.kleefkens@senternovem.nl

NORWAY

Mr Bård Baardsen
NOVAP
P.O. Box 6734, Rodeløkka
N-0503 Oslo
Tel. +47 22 80 5006
Fax: +47 22 80 5050
E-mail: baard.baardsen@rembra.no

SWEDEN

Mr Mattias Ceder (Team leader)
Swedish Energy Agency
Energy Technology Department
Electricity production and Energy Use Unit
Kungsgatan 43
PO Box 310
SE-631 04 Eskilstuna
Tel.: +46 16 544 2169
Fax: +46 16 544 2099
mattias.ceder@energimyndigheten.se

SWITZERLAND

Dr Thomas Kopp
Hochschule Rapperswil
On behalf of the
Swiss Federal Office of Energy
Energy Renewable Division
Oberseestrasse 10
8640 Rapperswil
Tel.: +41 55 222 4923
E-mail: tkopp@hsr.ch

UNITED KINGDOM

Dr Sandra Gómez
BRE Sustainable Energy Centre (BRESEC)
Garston, Watford WD25 9XX
Tel.: 01923 66 47 44
Fax: 01923 66 40 87
E-mail: gomez@bre.co.uk

USA

Ms Melissa Voss Lapsa
Oak Ridge National Laboratory
Engineering Science and Technology Division
Bethel Valley Road
PO Box 2008
Oak Ridge, TN 37831-6183
Tel.: +1-865-576-8620
Fax: +1-865-574-9331
Email: lapsamv@ornl.gov