

Fifth-generation thermal grids and heat pumps

A pilot project in Leuven, Belgium

Ir. P. Pattijn, Alex Baumans - Belgium

Belgium, the country of beer, fries and chocolate. But what energy sources are used? We have a large amount of nuclear power and a wide-spread gas network. Regarding power generation, wind power and solar power are taking up. But what are the alternatives to gas heating, considering the use of local energy sources and considering that the cooling demand will increase with respect to the heating demand? In this article we present an energy cocktail of a low temperature thermal grid of the fifth generation combined with ground sources, river energy and heat pump technology.



Download and share this article

Introduction

Thermal grids are receiving renewed interest thanks to a number of technical developments. On the user side, the heat demand of a modern home has reduced significantly, so that one can wonder if it is still useful to place individual, gas-fired heating units in each home. On the supply side, thermal grids offer the opportunity to make use of renewable energy or waste heat. Such systems can work with far lower temperatures than traditional district heating networks. The next step is to make the thermal grids interactive, so that users can extract both heat and cold from them. In the new residential project Janseniushof in Leuven, Belgium, a pilot installation is being built with this technology.

From Hertogensite to Janseniushof

This project is related to a large masterplan for urban renewal in the centre of Leuven. The district is called Hertogensite and is based on the renovation of the former St.-Rafaël - St.-Pieter hospital campus in the heart of Leuven. See Figure 1. Real estate developer Resiterra is building a new, sustainable, multifunctional urban development, a combination of new construction and deep renovation, on the 68 000 m² terrain. Since sustainability was paramount, it was decided to make use of a combination of renewable energy sources and two thermal energy networks: a local low-temperature energy grid with cold and heat storage (geothermal) in aquifers for the new buildings (heat requirement



Figure 1. Hertogensite and Janseniushof project development at Leuven.



Figure 2. Janseniushof development.

< 25 kWh/m² per annum) and a local district heating network at higher temperatures (90/70 °C) for the existing buildings (heat requirement < 70 kWh/m² per annum).

However, before the concept is applied on a large scale at the Hertogensite, it will first be put into practice in a smaller project nearby: the Janseniushof, see Figure 2. In this way, experience can be gained with a smaller project. The Janseniushof covers 25000 m² and is the redevelopment of the former car park of the hospital campus. The project comprises 206 housing units in 4 construction phases. The last two of these phases serve as the pilot for the Aquifer Thermal Energy System (ATES) and low-temperature energy network. It concerns 76 new apartments, 13 family homes and 13 service flats.

Fifth generation thermal grid

In several cities district heating has become an alternative heat supply system for gas boilers in new and existing buildings. District heating connected to homes with radiator heating have a supply temperature of 90 °C or 70 °C. They are referred to as third or fourth generation district heating grids.

However, fifth-generation thermal grids operate with low-temperature heating regimes, with a supply temperature of 40 °C or less. Depending on the application, the thermal grid can then directly supply a

low-temperature delivery system, such as floor heating. The primary temperature can also be increased by means of a decentralised heat pump. The advantage of this approach is that many more diverse types of low-temperature heat sources can be connected to the thermal grid, for example solar collectors, condensers of chillers and intercoolers of combined heat and power (CHP) installations, or industrial waste heat.

For the Janseniushof, we opted for a variant: the thermal grid is connected directly to the geothermal wells and acts as a heat source for the heat pumps in the homes. This gives the energy system an additional function: the network can also be used to cool. In summer, the homes have the possibility of free cooling via the floor heating system. This results in a pleasant indoor climate and has the additional advantage that the source can be recharged. The nearby river Dijle offers an extra possibility for recharging the source. If the source temperature drops too far at the end of the heating season, then in summer heat can be extracted from the river Dijle to recharge the heat source, see Figure 3 and Figure 4. In summer, river water at 20 °C is ideal for this. By extracting heat from the river, the urban heat island effect can locally be reduced.

In heating mode, the geothermal circuit has a supply temperature of 14 °C and a return temperature of 8 °C,



Figure 3. Janseniushof construction site and river Dijle

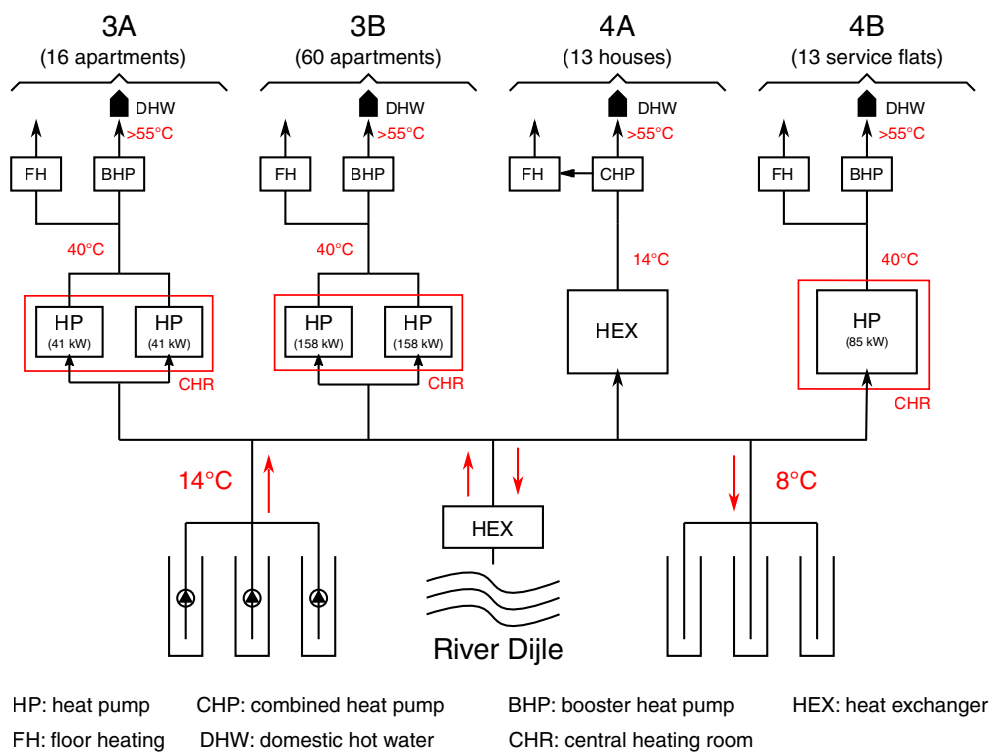

Figure 4. Overview of the thermal grid in Janseniushof.

as is shown in Figure 4. The advantage is that barely no heat is lost to the soil during transport. As a result the buried pipes do not have to be insulated. This saves a lot of time, money and effort.

Smart heat-pump system

Water to water heat pumps are applied to get the water in the primary circuit to the operating temperature. We opted for different configurations of heat pumps, depending on the type of home. See Figure 4. The apartments and service flats have a central heating room, where the heat pump heats the water to 40 °C, which is sufficient for the floor heating. For domestic hot water, each apartment has a buffer tank with a small booster heat pump that heats the water of the secondary circuit to 55 °C (with the possibility of higher temperatures depending on comfort and Legionella requirements). The central heat is produced and distributed at low temperature. This reduces the heat loss of circulating hot water and contributes to the energy efficiency of the system. The system can also react smoothly to a fluctuating demand for domestic hot water.

On the other hand, the houses each have their own combined heat pump for both space heating and domestic hot water production. A central heating room is less suitable here, for financial and practical reasons.

In summer, the flow of the geothermal system is reversed and the water of the primary circuit cools the building mass through the floor heating. There is a separate bypass installed for the bathrooms as residents do not appreciate cooling this space. In cooling mode, the water is pumped from the source at 9 °C and returned at 16 °C (not shown in the figure). As mentioned above, the return temperature can be increased further by using the river Dijle as a heat source.

Organisation and business model

An innovative technology such as a low-temperature geothermal energy network can only break through successfully with a viable business model. Such a system transcends the management of a traditional association of co-owners, and requires an energy manager. This role is taken up by the company IFTech. This company takes care of the detailed design, the execution, management, supply and the invoicing. In addition, they also take the role of investor of the low-temperature energy system. So, it functions as an Energy Service Company (ESCO).

The end customers pay a fixed contribution as a share in the operation of the geothermal energy system. The sharing of the individual costs depends on the configuration. In the homes which have their own heat pump installation, everything simply is paid via the electricity bill. The apartments, on the other hand, pay a share of the consumption of the central heat pump, whilst the consumption of the booster pump is for their own account. As a basic principle, the heating costs

should not be higher than those of a traditional system with gas boilers. A supply contract between ESCO and end customers was defined by the legal adviser.

The option of cooling is proposed and perceived as a significant added value and a commercial strength. The cooling consumption will not be charged, but is offered as an additional free thermal summer comfort. For a balanced operation of the system, as much cooling as possible is desired, for optimum recharging of the heat source. Offering the cooling function for free encourages the residents to use it.

The geothermal system has three doublets, each consisting of two wells (as a source of heat and cold). The sources have been executed redundantly (N+1). No backup operating on gas or any other heating technology has been installed. It was a deliberate choice by Ingenium. The option to use only electricity might entail a risk with regard to the development of energy prices. On the other hand, we are convinced that a ground source energy system completely driven by heat pumps offers the most ecological advantages.

Technical specifications

The geothermal energy network supplies four heating plants (see Figure 4):

- Building 3A (16 apartments) with two 41 kW heat pumps, supplemented by booster heat pumps for domestic hot water in the individual apartments.
- Building 3B (60 apartments) with two 158 kW heat pumps, also supplemented by booster heat pumps for domestic hot water.
- Building 4A (13 homes) each with an individual 8.9 kW combined heat pump, with an electric back-up.
- Building 4B (13 service flats) with an 85 kW heat pump, supplemented by booster heat pumps.

The choice of a double heat pump in the central heating room is based on the same concern for reliability as for the geothermal sources. As described above, there is no additional backup boiler and then it is safer to spread the capacity over two devices. Another reason for double heat pumps is related to the energy-efficiency at partial-load operation. The heat demand is defined for the most unfavourable conditions, which means that the installation works in partial load mode for most part of the year.

Conclusions

We believe that low temperature thermal grids using local energy sources in combination with heat pumps are the new alternatives to be used instead of gas fired boilers. A correct design and a feasible business case and business model headed by an energy service company (ESCO) are important key elements in the final result of high energy-efficiency, low CO₂ emissions, and a win-win for all stakeholders.

References

Baumans, A., *Warmtenetten van de vijfde generatie*, De Onderneming 941, June 2017, p 35-37.

ALEX BAUMANS

Distrigraph

Belgium

a.baumans@distrigraph.com

PEDRO PATTIJN

Business Unit Manager energy & sustainability

Ingenium

Belgium

pedro.pattijn@ingenium.be

ANNOUNCEMENT: European Heat Pump Summit 2017



Source: NürnbergMesse

The heat pump world meets in Nuremberg from 24 - 25 October 2017, where international experts discuss the European heat pump market, technology and application trends.

Product presentations at the Foyer-Expo supplement the variety of information provided by the speakers. The European Heat Pump Summit (EHPS) as a platform for specialists is intended for heat pump and component manufacturers, especially experts from science, research and development, and for planners, energy consultants, plant assemblers, and operators of local authority, commercial and industrial property.

With the two-day European Heat Pump Summit 2017, Nuremberg is offering the professional community an unique European platform for exchanging information and experiences. Now that the energy transition in Germany is being referred to all the time, the efficient utilisation of primary energy for heating and cooling is becoming more and more important. Heat pumps with innovative and impressive solutions can make a decisive contribution to sustainable energy systems here.

In the Congress during the EHPS, a number of interesting presentations are given. These include several presentations of Annexes within the HPT TCP, by their Operating Agents. In addition, the HPT TCP National Experts' meeting is being held on the day after the EHPS, Thursday, October 26.

<https://www.hp-summit.de/en>

Order Full Papers from the 12th IEA Heat Pump Conference

You can now order **all** Conference Proceedings (Full Papers) from the 12th IEA Heat Pump Conference in Rotterdam.
Price: 300 €

The Conference Proceedings (Full Papers) will be delivered on a USB flash drive (USB memory stick), after your payment is done.

[Link to the ordering form](#)