

COMPRESSION HEAT PUMP IN LEHEN - AUSTRIA

Kompressionswärmepumpe in Lehen



Fig 1: Residential complex Lehen [Salzburg AG]

Summary of the project

In Salzburg within the district "Lehen" apartment buildings with 287 apartments, a kindergarden, a student residence with 96 rooms, office and commercial space with an overall floor area of about 38 000 m² was built. This area and further existing buildings are supplied with heat via a micro district heating network.

The heat is supplied by a solar thermal system with a collector area of about 2 048 m² located at the roof of the buildings. Furthermore, a thermal storage of 200 m³ and a compression heat pump with a heating capacity of about 160 kW are installed. As additional heating system, a heat exchanger to supply auxiliary heat from an existing district heating network is installed. The flow temperature of the micro district heating network is about 65 °C and the return temperature varies between 35 °C and 45 °C.

The heat pump is connected via the condenser and evaporator to the thermal storage due to temperature stratification the lower part of the storage can be cooled

” THE SOLAR THERMAL SYSTEM IS THE MAIN HEAT SUPPLIER FOR A MICRO DISTRICT HEATING SYSTEM, DUE TO THE ADDITIONAL INSTALLATION OF A HEAT PUMP THE SOLAR YIELD IS INCREASED BY APPROXIMATELY 15-20 % ”

by the evaporator and the upper part of the storage can be heated by the condenser. Lower temperature at the bottom of the storage leads to lower return temperatures for the solar thermal system and thus to a higher solar yield.

The heat pump operates in two modes depending on the storage temperatures. In summer the heat pump supplies heat with a condenser outlet temperature of about 65 °C, which can be directly used within the micro



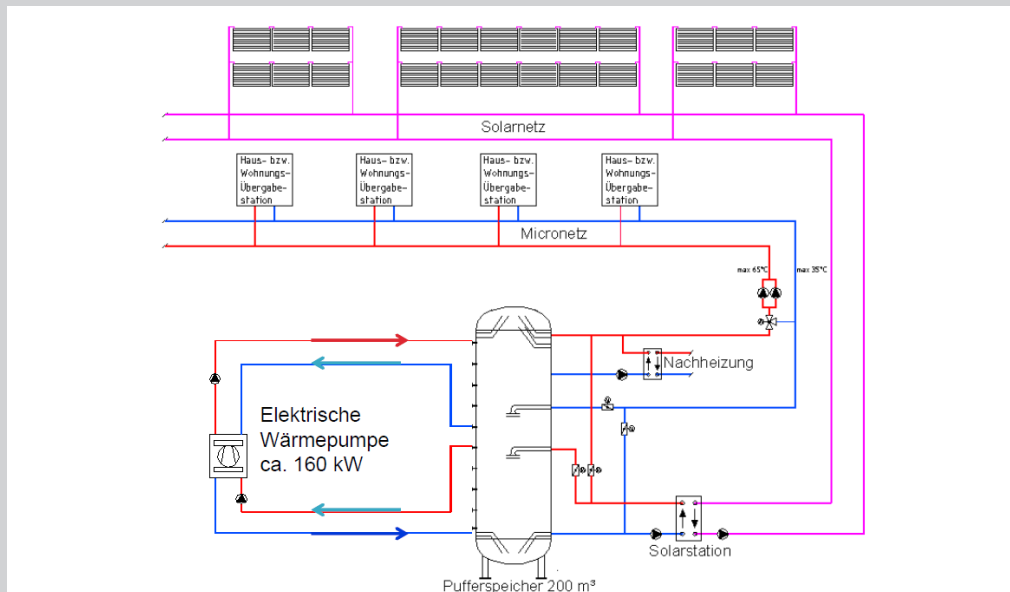

Fig 2: Hydraulic connections of the solar thermal system, heat pump, additional heating, thermal storage and micro district heating grid [Mahler, 2013]

district heating grid. The evaporator inlet temperature is about 37 °C. At these temperatures a COP_H of about 4.2 is reached.

In winter the condenser outlet temperature is about 45 °C to 55 °C. Due to the low condenser outlet temperature of the heat pump a further heating with the auxiliary heat exchanger is necessary. The evaporator inlet temperature is about 20 °C in winter. At these temperatures a COP_H between 4.4 and 5 is reached.

The heat pump (PWWHP180-WW) was manufactured by Meier Tobler AG and uses the refrigerant R134a.

Results

- The seasonal performance factor reached during the monitoring period a value of 4.6 and thus was higher than expected.
- The size of the thermal storage allows a temperature stratification of about 50 K.
- The solar yield of a solar thermal system is increased.
- The handling of high condenser inlet temperatures is a challenge especially at low volume flow rates.

References

Fink et al., 2016

Fink, C., Knabl, S., Wagner, W., Stelzer, R., Windholz, B., Helming, F., 2016, Wissenschaftliche Begleitforschung zum Förderprogramm "Solarthermie – Solare Großanlagen 2011"

Mahler, 2013

Mahler, B., 2013, STADT:WERK:LEHEN – Stadtteil-Revitalisierung mit optimierter solarer Nahwärme, Steinbeis-Transferzentrum für Energie-, Gebäude- und Solartechnik, Stuttgart

FACTS ABOUT THIS PROJECT

Building type: Residential buildings (300 apartments), office and commercial space

Heated floor area [m²]: 38 000

Installed heat capacity [kW]: 160

Heat source: Solar energy with thermal storage (200 m³)

Investment cost: 1 660 000 EUR (solar thermal system, micro district heating grid, thermal storage, heating center)

Participating countries: Austria

Time frame: In operation since 2013

Project organisation: Steinbeis-Transferzentrum für Energie, Gebäude- und Solartechnik, Landeswohnbaufonds Salzburg, Salzburg AG

Link to web page or report:

http://www.solare-grossanlagen.at/files/pdf/Endbericht_Begleitforschung_Solare_Gro%C3%9Fanlagen_2011_compressed.pdf
(in German)

Contact information

Sebastian Schuller, Salzburg AG

+43 662 8884 8916

sebastian.schuller@salzburg-ag.at

File compiled by Arnitz, A., Rieberer, R., Institute of Thermal Engineering, Graz University of Technology, 18.01.2018



IEA Technology Collaboration Programme on Heat Pumping Technologies (HPT TCP)