

WASTE HEAT RECOVERY AT THE STEEL AND ROLLING MILL MARIENHÜTTE GMBH, GRAZ (AUSTRIA)



Fig. 1: Heat pump at the location of the „Marienhütte“ (Götzhaber et al., 2017)

Summary of the project

A long-standing cooperation between the two companies, the energy service provider and district heating network operator Energie Graz GmbH & Co KG and the steel and rolling mill Marienhütte GmbH, has resulted in a project that is economically viable for both partners and ecologically valuable for the Graz region. The core of this cooperation is the use of process waste heat from the steel and rolling mill “Marienhütte” for district heating purposes.

Energie Graz GmbH & Co KG (“Energie Graz”) operates the district heating network in Graz and supplies around 65,000 households with a heating demand of about 1,200 GWh and a maximum heating capacity of 455 MW in the year 2017. The existing district heating network has a pipe length of about 790 km and is operated with a supply temperature in the range from 75 °C to 120 °C depending on the ambient temperature. The return temperature fluctuates between 55 °C in winter and 65 °C in summer, with an additional temperature fluctuation of up to 3 K during a day.

Furthermore, the apartments which will be built in the next years for about 12,000 inhabitants as part of the “Reininghaus” district development project will be supplied with heat from a new district heating network. This new district heating network will be operated with a supply temperature of about 70 °C

“DUE TO THE INSTALLATION OF TWO HIGHLY EFFICIENT LARGE HEAT PUMPS, PROCESS WASTE HEAT FROM THE STEEL AND ROLLING MILL MARIENHÜTTE GMBH CAN BE USED TO DELIVER ENVIRONMENTALLY FRIENDLY HEAT”

and a return temperature of about 40 °C and will be “physically” decoupled from the existing district heating network. The required heat for this new district heating network will be provided mainly by the heat pumps commissioned at the central energy station in 2016. The modular, expandable thermal water storage tanks are used to bridge downtimes of the heat pumps. Furthermore, a heat exchanger is installed as a backup system to transfer heat from the existing district heating network to the new district heating network.

The hydraulic connection of the heat pumps

Fig. 2 shows a simplified scheme of the hydraulic connection of the heat pumps to the heat source and sink. The heat pumps use process waste heat from the rolling mill water management (WaWi) circuit as a heat source. The



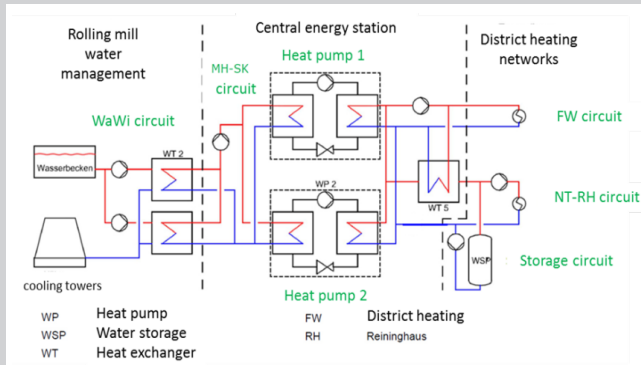

Fig. 2: Hydraulic connection of the heat pumps to the WaWi cooling circuit of the steel and rolling mill and the connection to the existing and the new district heating network (simplified illustration) (Unger, 2018)

connection to the evaporators of the heat pumps is realized using an additional circuit (MH-SK circuit) which is separated from the WaWi circuit with two heat exchangers (WT2). The water of the existing district heating network (FW circuit) or the water of the new low-temperature district heating network (NT-RH circuit) flows directly through the condensers of the heat pumps. In addition, the storage circuit and the heat exchanger (WT5) for the transfer of heat from the existing district heating network to the new low-temperature district heating network are shown.

The evaporators of the two heat pumps are arranged in parallel and are supplied with heat via two heat exchangers (2 x 3.9 MW) which are also arranged in parallel. The evaporator inlet temperatures are between 32 – 35 °C and the evaporator outlet temperatures are between 25 – 29 °C. The circulating pumps and a mixing valve can be used to control the temperature in the evaporator circuit.

The heat pumps

The installed heat pumps are two large heat pumps of the type Unitop produced by the company Friotherm. The dimensions of one heat pump are 8.2/3.7/3.3 m (L/W/H). One heat pump has a weight of about 30 tons and is filled with about 2 tons of the refrigerant R1234ze (GWP value lower than 1; see Bitzer, 2018). In each heat pump two turbo compressors are installed which can be operated in parallel or serial. A switching between parallel and serial operation is only possible during standstill. The maximum useful water temperature at the condenser outlet is 95 °C and can be reached in serial operation of the turbo compressors. In serial operation of the turbo compressors and temperatures at the condenser inlet/outlet of about 63/90 °C, a heating capacity of 3.3 MW per heat pump can be reached. In parallel operation of the turbo compressors and temperatures at the condenser inlet/outlet of about 43/69 °C, the maximum heating capacity increases to 5.75 MW per heat pump. The design temperatures at the evaporator inlet/outlet are about 33.8/29 °C in serial operation and about 33/25 °C in parallel operation. The heat pumps can also be used as cooling machines to supply an optional cooling network (which is not realized yet).

References:

- Kältemittel-Report 20, https://www.bitzer.de/shared_media/documentation/a-500-20.pdf, 15.11.2018
- Götzhaber, W., Meißner, E., Moravi, G., Prutsch, W., Schlemmer, P., Schmied, R., Slivnik, E., Zimmel, M., 2017, Wärmeversorgung Graz 2020/2030 – Wärmebereitstellung für die fernwärmeversorgten Objekte im Großraum Graz – Statusbericht 2017, Grazer Energieagentur Ges.m.b.H.
- Marienhütte, 2018, <https://www.marienhuetten.at/technologie/herstellungsprozess/>, 05.03.2018
- Schlemmer, P., 2017, Energiemodell „Graz Reininghaus“, Präsentation, Fernwärmetage in Loipersdorf 09.03.2017.
- Unger, H., 2018, Energiemodell Reininghaus – Abwärmeauskopplung Marienhütte durch Energie Graz, Technischer Kurzbericht

File compiled by Arnitz, A., Rieberer, R., Institute of Thermal Engineering, Graz University of Technology, www.tugraz.at, 15.11.2018

FACTS ABOUT THIS PROJECT

Building type: Residential and commercial buildings

Heated floor area: In total 11 000 buildings (30 % with hot water preparation) are supplied by the district heating network in Graz.

Installed heat capacity [kW]: 2x 5.750 (max.)

Heat source: Industrial waste heat

Participating countries: Austria

Time frame: Commissioning May 2016 (Heat delivery since 11/2016)

Project organisation: Energie Graz GmbH & Co KG

Link to web page or reports:

<https://www.youtube.com/watch?v=XSQGAPda0RU>

Contact information

Dipl.-WI (FH) Peter Schlemmer
Energie Graz GmbH & Co KG
☎ +43 (316) 8057 1630
✉ p.schlemmer@energie-graz.at

Dipl.-Ing. (FH) Helmut Unger
Energie Graz GmbH & Co KG
☎ +43 (316) 8057 1632
✉ h.unger@energie-graz.at



IEA Technology Collaboration Programme on
Heat Pumping Technologies (HPT TCP)