



13th IEA Heat Pump Conference
April 26-29, 2021 Jeju, Korea

PVT Geo Coupled Air to Water Heat Pump System Twin Test Cell Experimental Study

Euy-Joon Lee^{a,b,*}, Kwang-Seob Lee^{a,b}, Eun-Chul Kang^b, Yu-Jin Kim^{a,b}, Entchev Evgueniy^c, Libing Yang^c

^aKorea Institute of Energy Research, 152 Gajeong-ro, Yuseong-gu, Daejeon 34129, Korea

^bUniversity of Science and Technology, Korea, 217 Gajeong-ro, Yuseong-gu, Daejeon 34113, Korea

^cCanmetENERGY Research Centre, Ottawa, ON K1A 1M1, Canada

Abstract

A new PVT (Photovoltaic-Thermal) and ground coupled AHP (Air to Water Heat Pump) system has been developed and verified with a TTC (Twin Test Cell) in Korea. This renewable energy hybrid system technology could support Korea government's energy policies about RE3020(20% by renewable energy in 2030) and the zero energy building policy for the public sector in 2020 and the private sector in 2030. In this paper, a photovoltaic-thermal and ground air heat exchanger hybrid technology will be introduced for local and global energy issues. SET (Separate Effect Test) models have been developed to verify PVT, GAHX and AHP units performance. And also IET (Integral Effect Test) model with TTC has been developed to validate PVT-GAHX hybrid system performance. Initial commissioning of TTC both were matched in 99%. Seasonal test of heating and cooling weeks will be performed and introduced in terms of primary energy savings.

© HPC2020.

Selection and/or peer-review under responsibility of the organizers of the 13th IEA Heat Pump Conference 2020.

Keywords: Photovoltaic-Thermal(PVT), Ground Air Heat Exchanger(GAHX), AHP hybrid, Twin Test Cell(TTC), Demonstration, Primary Energy Saving

1. Introduction

Photovoltaic-thermal (PVT) and ground air heat exchanger (GAHX) hybrid system is a combined one with photovoltaic, solar thermal and geothermal technologies. The dual functions of the PVT system result in a higher overall solar conversion rate than that of solely photovoltaic or solar collectors and thus enable a more effective use of solar energy. GAHX system takes advantage of constant ground temperatures to precondition incoming fresh air hence reducing the heating and cooling loads. In this study, PVT and GAHX hybrid system were combined with air to water heat pump (AHP). The concept and the TTC site of hybrid system are shown as Fig. 1.

* Corresponding author. Tel.: +82-42-860-3514;
E-mail address: ejlee@kier.re.kr

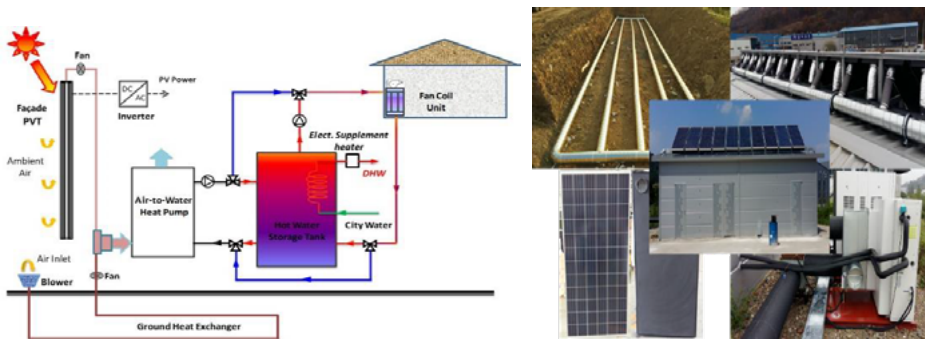

Fig. 1. PVT and ground coupled AWHP system (left) / IET TTC test site (right)

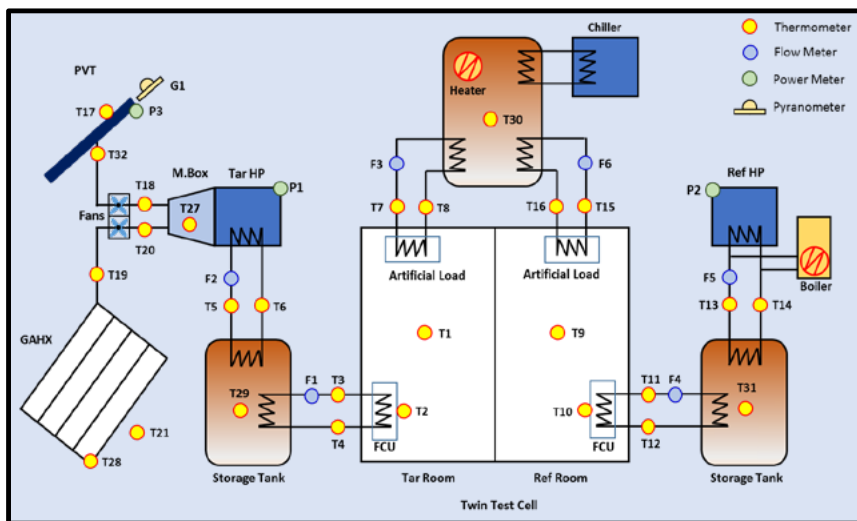

Fig. 2. TTC demonstration system schematic

2. PVT-GAHX Hybrid System TTC Study

The Twin-Test-Cell (TTC) facility (shown as Fig. 1) in Korea has been used as a testbed for HVAC components and systems testing and evaluation under real-life conditions. The Twin-Test-Cell consists of two identical rectangular-shaped rooms each with a dimension of 4m by 5m. Between the two test cells, there is an engineering room (3m by 5m) for locating the HVAC systems to be tested and compared. The horizontal ground-to-air heat exchanger is buried around the perimeter of the twin-test-cell and PVT panels are installed on the roof of the twin-cell.

The hybrid system to be installed at TTC is designed for an average detached house with the peak heating and cooling demand of 9 kW and 6 kW respectively. 10 PVT panels with a system power of 3.1 kW total have been installed power capacity and 40% of thermal efficiency and 200 m GAHX duct were installed in the ground and it is steel spiral type duct of 250 mm diameter. As the TTC (shown as Fig. 2) has the area of just 20 m² and a volume of 54 m³ and 32 temperature sensors, 6 flow meters, 3 power meters and 1 pyranometer.

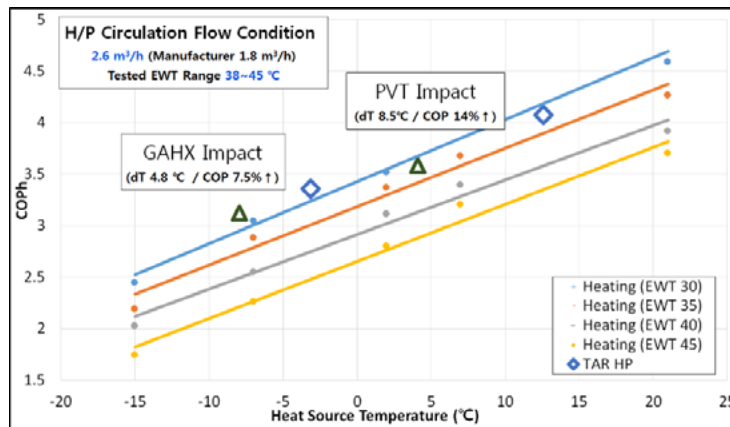

Fig. 3. AWP SET/IET performance data mapping

The AWP has 9.5 kWt heating capacity and its performance data are presented shown as Fig. 3. PVT and GAHX's contribution are described on Fig.3. Heating week test (2018.02.15~2018.02.22) was conducted target system (PVT-GAHX hybrid H.P.) and reference system (conventional H.P.) at the same time for a week. The target AWP COP was 4.0 while the reference was 3.4. The hybrid system's COP increase due to source temperature increase (Shown in Fig. 3) and it is about 15% performance improvement from the coupling of the PVT and ground heat exchanger system.

3. Conclusion

PVT and ground coupled TTC system has been introduced and developed to justify the IET model by comparing the reference and the target system with the solar and geothermal component. Twin test cell with the hybrid system was installed in a local actual site and initial commissioning test has been performed with a good accuracy more than 99%. The hybrid system's COP increase due to the source temperature advantage was consistent and justified with IET and SET. GAHX impact 4.8°C on source temperature, contributed 7.5% COP and PVT impact 8.5°C on source temperature, contributed 14% COP improve. For the heating season week performance comparison test, the target system with PVT-GAHX hybrid system showed a 15% energy saving of the target system in the location and the test cell conditions. In addition, the system achieves lower primary energy consumption in comparison to the Reference boiler-chiller system. The annual primary energy saving expected as 45% in Korea by yearly simulation methodology. The system components' contributions to these saving vary during the seasons but in general are due to the multipurpose renewable utilization and high heat pump COP. For the future work, a shoulder month week and cooling month week test will be conducted for a seasonal and yearly performance data improved justification.

Acknowledgements

This work was supported by the Korea Institute of Energy Technology Evaluation and Planning(KETEP) and the Ministry of Trade, Industry & Energy(MOTIE) of the Republic of Korea (No. 20188550000430).

References

- [1] Eugeni Entchev., et. al., 2017, "CO2 free heating, cooling and power trigeneration system joint research 2nd year report"
- [2] E. J. Lee, et. al., 2017, "Smart Hybrid Renewable Microgeneration System for Residential Applications", Int. J. of Global Warming. <https://doi.org/10.1504/IJGW.2017.087212>
- [3] Anil Kumar, Prashant Baredar, Uzma Qureshi, 2015. "Historical and recent development of photovoltaic thermal (PVT) technologies", Renewable and Sustainable Energy Reviews 42, 1428-1436. DOI: 10.1016/j.rser.2014.11.044

- [4] Chow T.T., 2010. "A review on photovoltaic/thermal hybrid solar technology", *Applied Energy* 87, 365-379. DOI : 10.1016
- [5] Abdeen Mustafa Omer, 2008. "Ground-source heat pumps systems and applications", *Renew Sustain Energy Rev* 12 344-371. DOI: 10.1016