



13th IEA Heat Pump Conference  
April 26-29, 2021 Jeju, Korea

## Combined Heating and Cooling in District solutions

Jussi Alpua\*, Martti Kukkola

Oilon Oy, Niittytie 25 A, Vantaa 01300, Finland

### Abstract

Energy companies can now produce energy efficient cooling with heat pumps outside of the traditional district cooling network. Property-specific heat pumps can be used to provide cooling services to customers within the energy company's district heating network. This concept makes it possible to offer energy efficient cooling services to customers without having to build a district cooling network. In property-specific cooling, the heat pumps are installed in the customer's property produces cooling and transfer the generated heat into the district heating network. The cooling service offered to the customer acts as decentralized heat source for the district heating network. In this Combined Heating and Cooling (CHC) concept, energy is not wasted. In many commercial and office buildings, hospital, datacenter as well as apartment buildings can be changed environment friendly cooling in future.

© HPC2020.

Selection and/or peer-review under responsibility of the organizers of the 13th IEA Heat Pump Conference 2020.

*Keywords: heat pump; district cooling; district heating; combined heating and cooling; CHC*

### 1. Introduction

The low carbon roadmap published by the European Commission in December 2011 aims at a near-zero emission energy system by 2050. For example, Finland's long-term goal is to reduce greenhouse gas emissions by 80 % by 2050. These more stringent political climate goals, increasingly volatile and lower wholesale electricity prices, and customer awareness of the need for renewable energy production forms to combat climate change are driving district heating companies to look for new energy sources and heat production forms. The use of heat pumps in a district heating system enables the utilization of a wide variety of different heat sources and increases the flexibility of the district heating system and the share of renewable energy production. According to the study, heat pumps could produce between 3 to 4 terawatt hours (TWh) of district heat per year, which would represent 9-13 percent of the annual sales of district heat in Finland. Current district heat production from heat pumps in Finland is about 0.6 TWh, which is around 1.7 percent of the total district heat production. In Sweden, for example, about 7.4 % (4.0 TWh) of district heat is generated by heat pumps [1].

This article looks at property cooling solutions implemented with heat pumps. In the implemented solutions, the cooling energy (cold water) required by the property is produced by heat pumps and the condensate energy generated in the production of cooling energy is transferred to the district heating network for further utilization of thermal energy. Typically, the cooling of the real estates is implemented with a cooling solution, in which the condensate energy generated during the cooling is not utilized and condensate energy is lost through outdoor condensers to the air.

\* Corresponding author. Tel.: +358-44-337-4475; fax: +358-3-857-6239.  
E-mail address: jussi.alpua@oilon.com .

The implemented solution can be applied and is sensible to apply to large properties that require cooling and are not able to be connected to the district cooling network and have been connected or will be connected to the district heating network. A large property here refers to a property with a design cooling power greater than ~ 30 kW.

**2. The principle of cooling the property by heat pump**

Figure 1 presents a cooling solution to a property, in which the condensate heat generated during cooling is transferred to the district heating network by use of a heat pump (lower example). Figure 1 also shows a conventional cooling solution in which condensate energy generated during cooling is transferred to the outdoor air via a heat transfer fluid (upper example). Heat pump and water chiller unit share similar operation principles. The temperature level of the water/liquid leaving from heat pump is high enough to utilize the condensate energy to the heat sink. For example in this figure 1 only adding 100 kW of electricity, there can be heat recover 600 kW high temperature water, instead of losing 500 kW to the air with chiller.

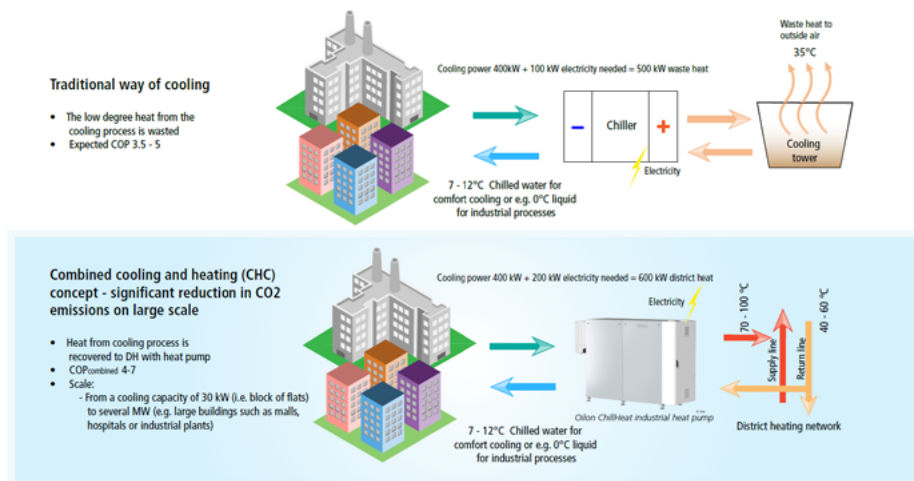

Fig. 1. Above is a traditional cooling solution in which condensate energy produced by cooling is transferred to the outdoor air via a heat transfer fluid. Below is a real estate cooling solution with a heat pump, where the condensate heat generated during cooling is transferred to the district heating network

The combined heating and cooling (CHC) system is not tied to any specific constant temperature like district cooling networks are. For example, the system can produce cooling liquid of -5 °C while recovering heat to the district heating network. In addition, the system can be installed in a small space. This is an advantage when operating normally on the client's existing premises.

Heat pump energy balance is:

$$Q_H = Q_c + P_e - Q_q \tag{1}$$

where

- Q<sub>c</sub> = cooling energy of the heat pump (kWh)
- P<sub>e</sub> = electric energy consumed by the heat pump compressor(s) (kWh)
- Q<sub>H</sub> = condensate energy of the heat pump (kWh)
- Q<sub>q</sub> = heat losses of the heat pump to the environment (kWh)

The heat losses of the heat pump to the environment (engine room) are typically about 3 % of the electric energy with compressors equipped with semi-hermetic frequency converters.

The energy efficiency of cooling processes can be examined with the so called cooling efficiency factor ( $\epsilon$ ), defined by the formula:

$$\epsilon = \frac{Q_c}{P_e} \quad (2)$$

The cooling efficiency of the cooling process depends on the temperature of the water (liquid) leaving the evaporator and condenser. The larger this temperature difference, the worse the cooling efficiency of the cooling process. The so called overall efficiency of the process can be determined to the cooling process, in which the condensate energy can be utilized:

$$\varphi_{tot} = \frac{Q_c + Q_H}{P_e} \quad (3)$$

If all the condensate energy generated by the cooling process is utilized, the overall efficiency as a function of the cooling efficiency is:

$$\varphi_{tot} = 2\epsilon + 1 \quad (4)$$

### 3. The cooling solution for the property with a heat pump implemented in 2017

In 2017, a heat pump system was delivered for cooling the property, in which the condensate energy generated during cooling is transferred to the district heating network for further utilization according to the principle shown in the figure 1 (lower example). The design cooling capacity of the property to be cooled was calculated to be approximately 500 kW. Cooling water is utilized for cooling the property during warm periods and for condensate heat recovery of the year-round commercial refrigeration.

Two serial connected Oilon ChillHeat heat pumps were selected, based on the design cooling capacity of the property. Figure 2 shows the performance of the selected heat pump. Cooling water outlet is 10 °C and heating side outlet is 80 °C. Calculated total COP is 5.4. The heat pump performance is calculated using the Oilon Selection Tool program developed by Oilon Oy.

The selected heat pumps each have three piston compressors. In one heat pump two compressors are equipped with frequency drives (VFDx2). The six compressors in total achieve stepless cooling capacity control in the range of 8 %...100 %. Due to the control method of the heat pump, the efficiency of the heat pump remains almost constant throughout the power control range. In the implemented project, the heat pump and the cooling system require good adjustability, since the need for the cooling capacity of the property varies greatly e.g. depending on the outdoor temperature.

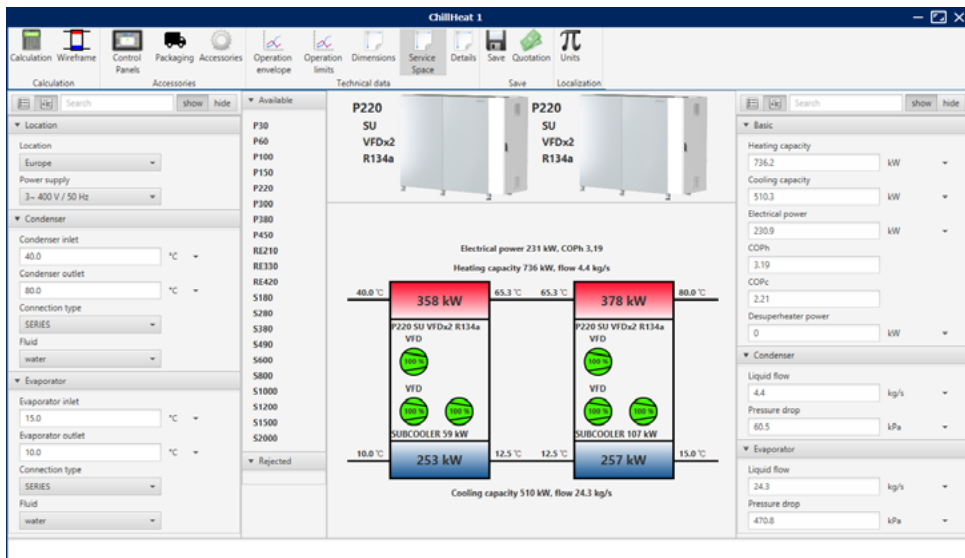

Fig. 2. Design information for the heat pump. The heat pump performance is calculated using the Oilon Selection Tool program

3.1. System description

The principle PI diagram of the system is presented in the figure 3. The system consists of the following main components:

- heat pump and automation (1)
- storage tank for the cooling circuit (2)
- cooling circuit circulation pump with a frequency converter (3)
- energy metering of the cooling circuit (4)
- district heating circuit pump with a frequency converter (5)
- district heating energy metering (6)
- district heating circuit 2-way control valve (7)
- district heating circuit check valve (8)
- filters (9)
- Electrical cabinet (10)

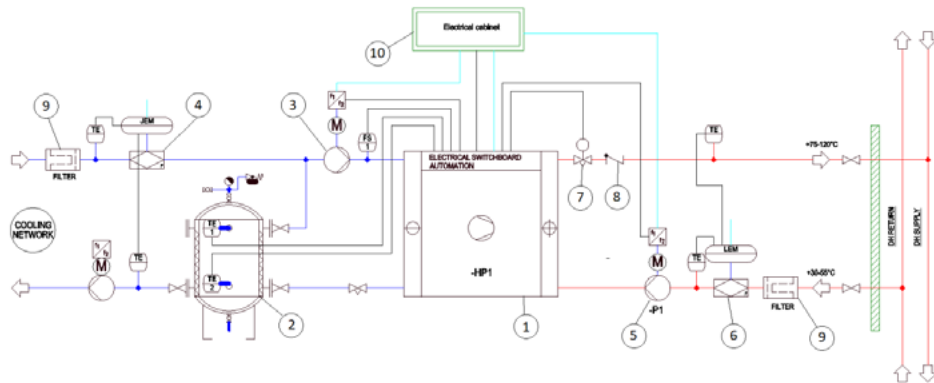

Fig. 3. Principal PI diagram for combined heating and cooling solution

The system does not need external control or automation to operate. The heat pump receives a running permission according to the lower temperature of the cooling accumulator. First, the circulation pumps (3 & 5) are started, both in the cooling and heating circuit. The cooling circuit is equipped with a flow switch (FS1) which detects the flow. When the flow is detected, the heat pump (1) can start.

The cooling power is controlled by adjusting the heat pump power, (1) and the temperature to the cooling network is controlled by changing the flow rate of the circulation pump (3). A set value for the outgoing water in the heating circuit is also set to the heat pump automation. This temperature is controlled by changing the flow rate with the frequency controlled pump (5) and the control valve (7). The control valve control is used when the circulation pump control range runs out. This ensures that the water entering the network is at the set point temperature. The heat pump will shut down after a delay when the power requirement is so low that it does not correspond to the minimum load on the unit.

3.2. Implemented system running in year 2019

This implemented solution was producing cooling approximately 850 MWh in year 2019. Heat pumps were consuming electricity 373,8 MWh and 80 °C hot water were produced 1 224 MWh. Total COP was 5,55. So the COP is higher than calculated COP. Note that this COP doesn't include circulation pumps electric consumption.

The system is owned by an energy company. Energy company is responsible for the running costs electricity and maintenance. Customer pays for the cooling energy. They also receive a compensation for the recovered heat. The energy company has not announced the price of sold cooling energy. Electricity price in Finland is typically 80-100 €/MWh without taxation. This size CHC solution installation costs are typically 450-480 €/kW (cooling). This price doesn't include pipe work from district heating network to machine room.

#### 4. CHC in the future

The future looks bright for the CHC solutions. Last two years Oilon has supplied more than 20 CHC solutions in Nordic countries. This is just a start. For example energy companies in Finland have begun to open district heating networks, so that third party can access networks if the agreements can be settled.

Moving to 4<sup>th</sup> generation district heating networks give also more advance to CHC solution. In 4<sup>th</sup> generation district heating networks supplied water temperature will be low as 70 °C and even lower. Decentralized large scale heat pump systems are named one of the heat sources to the 4<sup>th</sup> generation district heating networks. Heat pumps can produce heating to the buildings as well as they can be used for 2-way district heating as CHC is. [2]

Lower network temperature will increase the CHC system efficiency and decrease the capital costs. Also lower temperature gives better possibility to use CHC solution storage tanks as heat storage when cooling is not needed. This of course needs some modification for the current system piping.

Maybe the best efficient way to use CHC is 5<sup>th</sup> generation district heat networks. This generation is using heat sharing networks where the temperature is near ambient ground temperature. Heat pumps are installed in customer buildings, as in CHC concept. Heat sharing networks can be used as heat source for the heating as well as for rejecting the heat to the network when a building needs cooling. This increases the CHC efficiency, because the heat pump condensing temperature can be much lower. [3]

#### 5. Summary

The low carbon roadmap published by the European Commission in December 2011 aims at a near-zero emission energy system by 2050. Finland's long-term target is to reduce greenhouse gas emissions by 80% by 2050. Cooling large buildings with heat pumps enables the condensate energy generated by cooling to be utilized in the district heating network, which reduces the amount of district heat produced by fossil fuels in the district heating network.

Combined Heating and Cooling solution (CHC) is simple, functional and effective system. Heat pump total COP can be over 5,5 when producing 10 °C cooling and 80 °C hot water. These systems can be implemented in new and existing properties.

CHC potential can be seen to increase in future. District heating companies are more and more opening the networks to third parties. Also moving forward to use 4<sup>th</sup> and 5<sup>th</sup> generation district heating networks increases the use of CHC's. Lower network temperature, decentralized sources and 2-way network will increase the benefits of using heat pump systems like CHC.

#### References

- [1] Passi, Pekka et al. 2016. Suuret lämpöpumput kaukolämpöjärjestelmässä. The final report on August 29, 2016. Finnish Energy. PDF publication of 50 pages. Available: [http://energia.fi/files/993/Suuret\\_lampopumput\\_kaukolampojarjestelmassa\\_Loppuraportti\\_290816\\_pai\\_vitetty.pdf](http://energia.fi/files/993/Suuret_lampopumput_kaukolampojarjestelmassa_Loppuraportti_290816_pai_vitetty.pdf)
- [2] H. Lund et al., "4th Generation District Heating (4GDH) Integrating smart thermal grids into future sustainable energy systems," Energy, vol. 68, pp. 1–11, Apr. 2014.

- [3] S. Buffa, M. Cozzini, M. D'Antoni, M. Baratieri, and R. Fedrizzi, "5th generation district heating and cooling systems: A review of existing cases in Europe," *Renew. Sustain. Energy Rev.*, vol. 104, pp. 504–522, 2019;