

# Heat Pump System Improved High-Temperature Borehole Thermal Energy Storage Efficiency

Olof Andersson, Geostrata HB Sweden  
Leif Rydell, Reikab AB Sweden  
Niklas Håkansson, Xylem Sweden

In 2010 Xylem, in Emmaboda, Sweden, installed a High-Temperature Borehole Thermal Energy Storage (HT-BTES). The idea was to store waste heat in the summer season to use later for space heating in the winter. The system worked adequately for charging the storage, but turned out to be much less effective for extracting the stored heat. By installing a heat pump system to support heat extraction, the system now works properly both ways. This article presents the energy performance and economics of such a system.

## Introduction

In 2010 an HT-BTES was put into operation at Xylem factories in Emmaboda. The storage was designed for charging 3.6 GWh of waste heat in summer, of which 2.6 GWh was estimated to be recovered for space heating the winter. In this way, a significant amount of purchased district heating was expected to be replaced (Figure 1).

Until 2014 the storage was heated to around 40°C. However, during this period the storage acted perfectly as a relief for the cooling tower. Some heat was recovered during the following years, but much less than expected. To improve the recovery, a heat pump system was installed in 2018. The reconstructed system is now being used for performance measurements and evaluation in IEA HPT Annex 52 (Long term performance measurement of GSHP systems), and this article summarizes the findings after three seasons.

## System description

The storage consists of 140 boreholes, 150 m deep and with a borehole distance of 4 m. It is located just outside the factory area and has a rectangular shape measuring 60 x 40 m. On top there is a layer of sand, foam glass, and humic soil as insulation.

A coaxial type heat exchanger was developed as borehole heat exchanger (BHE). It consists of two pipes with intermediate insulation by unmovable water. A helical spacer was placed in each joint. An advantage of using this type of BHE is that it enables bidirectional flow. Thus, the highest storage temperature can always be at the bottom of the storage. The use of coaxial BHE means that the heat carrier is in direct contact with the groundwater in the bedrock, approximately 3.5 m below the surface. This also means that the heat carrier must be circulated under vacuum pressure (35 kPa) in the storage. The

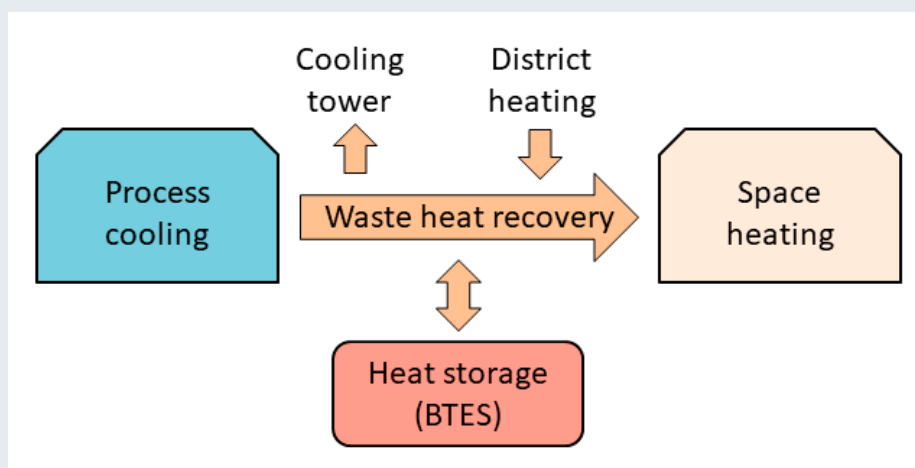

Figure 1.

Xylem's system for heat recovery from process cooling, including BTES heat storage for seasonal storage of waste heat. This reduces energy losses through the cooling tower for cooling and purchased district heat for space heating.

vacuum created problems with cavitation of the circulation pump during the first years of operation, as well as problems with degassing the fluid. These problems, and how they were solved, are described in reference [1].

The borehole field is divided into seven sections with 20 holes in each. The three inner sections form an “inner core” intended to have the highest temperature, and the four outer sections form a “buffer zone” with a slightly lower temperature. The idea behind this design is simply to have demand-adapted temperatures at charging and discharging modes. This function is achieved by using control valves for each section, as shown in Figure 2.

The storage is connected to the main technical central by a 200 m long steel culvert in which the heat carrier is circulated by using a frequency-controlled circulation pump. The pump is designed for a maximum flow rate of 21 l/s. Heat is stored into, or extracted from, the storage through a large heat exchanger. The system has sensors for instantaneous recording of temperatures, flow rate and pressure. Furthermore, the rock temperature in the storage (MW-1) and just outside is measured in two monitoring boreholes (MW-2). Also, the function of the insulation on top of the storage is measured by three temperature sensors, see Figure 2.

**Operational results**

During the first years of operation, the expected amount of waste heat with a high enough temperature was found to be insufficient. Therefore, a number of measures were taken to capture low-value heat sources by using heat pumps. A heat pump was installed to extract heat from the foundry's ventilation system. As a bonus, this solution also provides air conditioning for this otherwise “hot” workplace.

During 2014-2015, the storage temperature was stabilized to be approximately 40-45°C even though the availa-

bility of waste heat remained high. It became more and more obvious that instead of an increased temperature, a lateral growth of the storage took place. Hence, the storage temperature was not high enough for heat recovery by direct heat exchange only. Actually only some 10-15% of the stored heat could be recovered this way during 2015-2017.

To achieve an enhanced withdrawal of heat, a heat pump system [1] was recommended. It was also recommended to lower the working temperature of storage to a working temperature of 40/20°C. In this way, the thermal gradient should be turned towards the storage during the winter season and thus the spread sideways would cease. At the same time, the capacity using the storage for cooling would be increased by the reduced temperature.

In the autumn of 2018, the heat pump system shown in Figure 2 was put into operation. The system consists of 8 parallel-connected aggregates (NIBE F1345-60). The evaporator side connects to the storage and the condenser side to the internal heating network. The evaporator side works at the temperature 26/20°C, while the condenser side delivers a temperature up to 55°C. The system covers the heat demand down to an outdoor temperature of about -5 degrees. At lower temperatures, the external district heating is used as backup. The high temperature of the evaporator side allows the system to deliver a condenser capacity up to 800 kW. This is significantly higher than the nominal, 480 kW.

As shown in Figure 3, the heat pump system has provided a drastically increased recovery from the storage since the start in September 2018. Consequently the storage temperature has been gradually lowered. At the end of April 2021, it was down to 28°C and still leaves a large portion of earlier stored heat to be recovered from the sides of the storage.

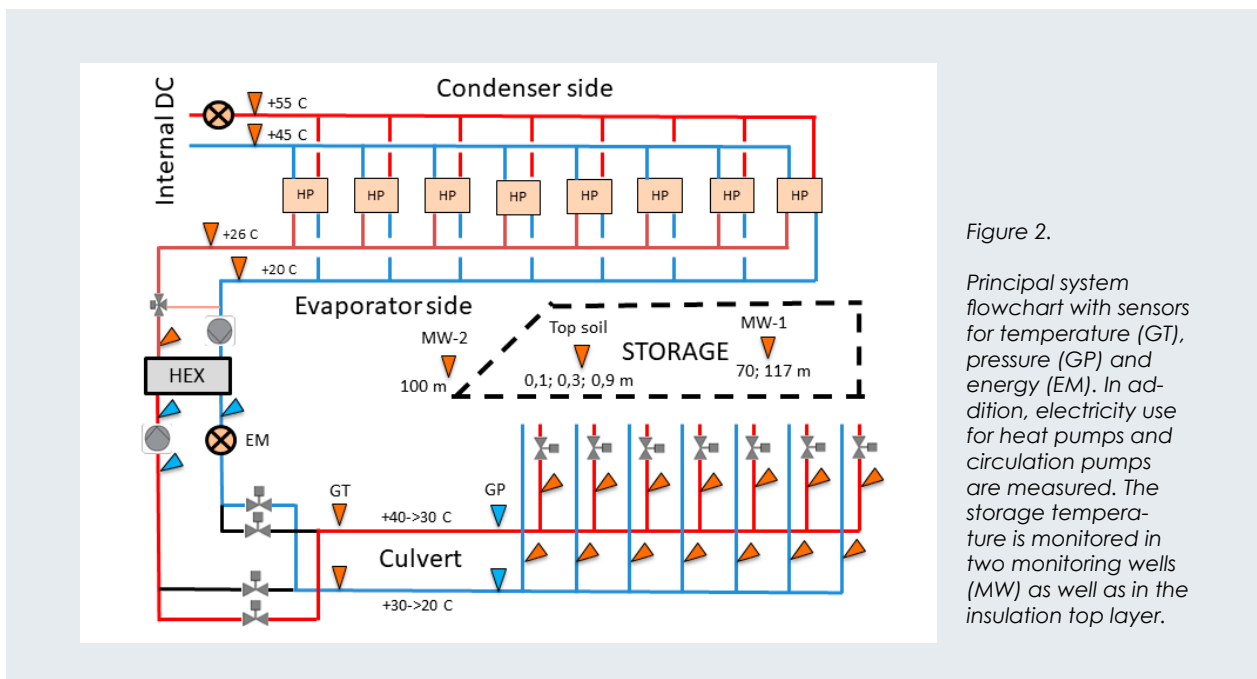

Figure 2. Principal system flowchart with sensors for temperature (GT), pressure (GP) and energy (EM). In addition, electricity use for heat pumps and circulation pumps are measured. The storage temperature is monitored in two monitoring wells (MW) as well as in the insulation top layer.

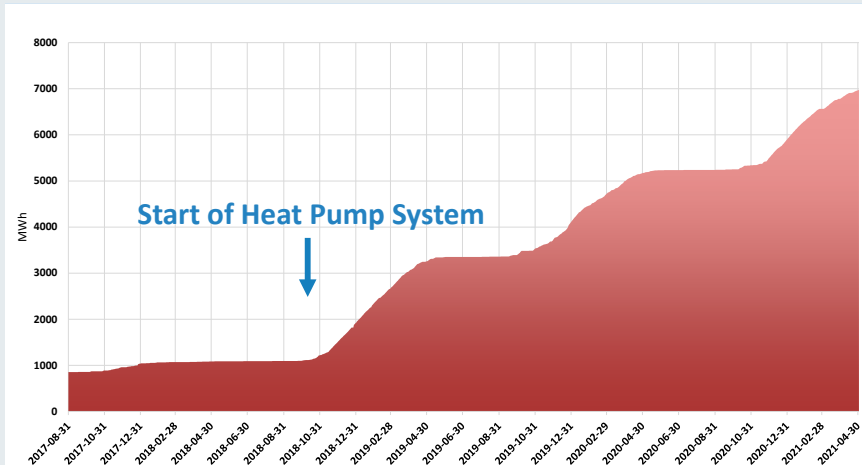

Figure 3.

Accumulated heat recovery from the storage over the last five years.

Heat from BTES (MWh)	Produced by HP (MWh)	Electricity used (MWh)	SPF (-)
5 060	6 500	1 440	4.5

Table 1. Production of heat from the heat pumps and the system performance factor (SPF), electricity for circulation pumps included, for the heating seasons 2018/19-2020/21.

The lowered storage temperature also brings several other advantages:

- » Significantly higher cooling capacity during the summer, which in turn means less use of the cooling tower and a higher COP for low-grade waste heat capture by the heat pumps.
- » Reduced heat losses, modeled to be on the order of 20-30% less [1].
- » Reduced cavitation risk of the storage circulation pump that works under vacuum pressure and less need for degassing the heat carrier fluid.

### Economics and efficiency

The investment cost of the BTES system in 2010 was approximately SEK 12 million. By replacing 2000 MWh/year of district heating, the investment payback period was calculated as 5-6 years. However, only some 1200 MWh was recovered by the spring of 2017. This was a disappointing result. On the other hand, the investment in the storage concept led to an enhanced recovery of low-grade heat by using heat pumps. These installations were in themselves profitable by increasing the direct heat recovery to increase from 2000 up to 7000 MWh the last winter. Thus, the BTES system became a profitable investment, even without the anticipated extraction of stored heat.

Other not priced advantages have been noted. For example, the foundry got “free” climate cooling, the amount of city water for cooling in test pools declined significantly, and the operating and maintenance costs of the cooling tower decreased.

The additional investment in the new heat pump system 2018 totaled SEK 2.5 million. The system has delivered 6500 MWh to the heat network during the first three winter seasons. The electricity used for the heat pumps and the circulation pumps was 1440 MWh. This means

a system performance factor of 4.5 and a net saving of 5060 MWh, (78%). For Xylem this is worth about SEK 3.8 million, which means that the additional investment payback took place after just 2 years.

### Conclusions

The HT-BTES case at Xylem showed that a heat pump system for heat recovery is needed for full recovery of stored heat. It also serves as proof that such a system in itself is highly profitable and can be operated at a high system performance factor, in this case a SPF of 4.5. The additional investment was paid off in less than three years. Hence, it is highly recommended for similar projects to consider using heat pumps for heat extraction already from the start.

The use of high-efficiency borehole heat exchangers with double flow direction has not helped to obtain a long-lasting high temperature upon recovery. Such a type of BHE may instead create technical problems, such as cavitation and striping of gas, as has been experienced in Emmaboda. Using conventional collectors (U-pipes) is therefore recommended in order to avoid such problems.

### References

- [1] Nordell, B., Liuzzo Scorpio, A., Andersson, O. Rydell, L., Carlsson, B. 2016. “The HT BTES plant in Emmaboda. Operation and experiences 2010-2015”. Div. of Architecture and Water, Luleå University of Technology, January 2016.

**OLOF ANDERSSON**

**Geostrata HB**

Sweden

[olle.geothermal@hotmail.com](mailto:olle.geothermal@hotmail.com)

<https://doi.org/10.23697/b8tt-8130>