



14th IEA Heat Pump Conference
15-18 May 2023, Chicago, Illinois

Development of a gas absorption heat pump for residential applications

Tommaso Toppi^{a*}, Lorenzo Pistocchini^a, Marco Guerra^a, Luigi Tischer^b, Pietro Brevi^b

^aPolitecnico di Milano, via G. La Masa 34, 20156 Milano, Italy

^bAriston Group, Via della Vignolina 2, 20864 Agrate Brianza (MB), Italy

Abstract

Thermally Driven Heat Pumps represent an option to reduce the energy consumption for space heating and domestic hot water in hard-to-decarbonize buildings without impacting the electrical grid and utilizing the current and future gaseous energy vectors with high efficiency. Ariston Group and Politecnico di Milano developed a gas absorption heat pump for the residential market, exploiting design and manufacturing solutions to enable large-scale production and introducing technical features to assure high performance over the entire working range.

In particular, the use of a variable restrictor setup coupled with a patented solution, called “booster”, can reduce the temperature of the generator at high load and high lift conditions, enabling the heat pump to provide the nominal capacity from -22 °C to +40 °C of outdoor air temperature, with supply temperature up to 70 °C. Moreover, coupled with a specifically designed combustion system, the heat pump can modulate at 1:6 ratio of its nominal capacity. This feature makes it possible to maintain high efficiency also at part load conditions, avoiding the on-off operation and making redundant the installation of inertial buffer.

Additionally, an innovative strategy to perform the defrosting of the air-sourced heat exchanger without the need of acting on the thermodynamic cycle has been developed. This allows defrosting operations extremely fast, while offering an almost negligible effect on the heat pump performance and substantially no interruption to the heating service and contributing to the elimination of the need to install an inertial buffer.

The thermodynamic core of the appliance was built targeting large scale production. It allows for high specific capacity (kg/kW) and a small footprint (m²/kW) with the ability to serve nominal capacities ranging from 8 to 15 kW based on the configurations. Laboratory test to assess the performances based on the European Standard EN 12309 returned a seasonal gas utilization efficiency on the net calorific of 1.50, a seasonal primary energy ratio of 1.27, and extremely low electrical consumption for the auxiliaries.

© HPC2023.

Selection and/or peer-review under the responsibility of the organizers of the 14th IEA Heat Pump Conference 2023.

Keywords: gas absorption heat pump; residential application; seasonal efficiency; defrosting.

1. Introduction

Many authors have already highlighted the importance of the climatization of the building stock toward the reduction of the primary energy consumption and CO₂ emissions. The built environment, particularly in western world, is characterized by several aspects:

- limited presence of high efficiency buildings, i.e. buildings with heat demand lower than 25 kWh/(m² year)
- large presence of existing buildings with energy consumption above 150 kWh/(m² year)
- low replacement rate, with less than 1% of building stock replaced annually by new buildings [1]
- presence in existing buildings of high temperature emitters, in particular radiators in Europe and heat exchangers for air ducted systems in North America.

* Corresponding author. Tel.: +39 02 2399 3964
E-mail address: tommaso.toppi@polimi.it

To achieve a substantial reduction in primary energy consumption and in CO₂ emissions, a solution that could deliver substantial savings in the retrofit of existing buildings is needed. Indeed, the distinction between the new buildings and the existing buildings is pivotal to ensure that the reduction of emissions is achieved in the shortest possible time. While new buildings enjoy access to state-of-the-art construction technology, and large degrees of freedom in terms of architectural decisions (surface-to-volume ratio, orientation, size and position of windows, etc.), the retrofit of existing buildings has to face a high number of constraints including a limited budget and often the presence of the landlord during the retrofit (existing buildings cannot be easily vacated). Nevertheless, the large number of existing buildings with large yearly energy needs for space heating and the extremely high heat demand of these buildings make this challenge the most relevant and crucially important to address the overall challenge of reducing emissions.

To facilitate the adoption in the existing buildings the optimal solution needs to minimize the installation hurdles, i.e. not requiring changes to the existing emission systems in the building (radiators and diameter of piping). This requirement implies working with high output temperatures (up to 70 °C) and the limited flow rates typically used in systems designed for boilers that often do not exceed 1000 l/hour. Moreover, limited requirements for auxiliary equipment (inertial buffer, etc.) and the possibility to leverage the skills and competence already available in the installer base by avoiding forcing them toward new certification are crucial. At the same time, the proposed technology would need to meet the following requirements:

- Lower operating costs than state of the art (usually a direct combustion system).
- Low noise level to minimize the possible impact on outdoor quietness, in compliance with local legislation, even in presence of limited distance from the neighborhood's property.
- Ability to deliver heat with constant power output particularly in high thermal lift conditions, typical of the most demanding climates of the North European and North American regions.
- Ability to serve both the space heating and the domestic hot water function to maximize the benefits to the overall heat demand of the building.
- Environmental benefits in terms of reduced global warming emissions (CO₂, F-Gas), reduced ozone depletion emissions (F-Gas) and reduced human health hazardous emissions (PMs, NO_x, OGCV).

In addition, a solution that could be rapidly adopted will need to be compatible with the energy system in place and the one prospected in the future. Therefore, the reduced electrical load (not to rely on an already overloaded grid) and the ability to work with green gases (bio-methane, bio-LPG, hydrogen blends) is required.

Gas driven heat pumps meet these requirements, since they can be designed to work at high temperature, matching the needs of high temperature heating systems, and rely on an already existing and high-capacity gas network. Compared with existing fuel driven heating systems, as boilers, gas heat pump provide a substantial reduction of the gas consumption with a minor increase of the electricity needs. In [2] two prototypes with a nominal capacity of 23.5 kW have been tested and a seasonal gas utilization efficiency of 1.36 (based on gross calorific value) has been achieved, considering the climate region IV of the American and Canadian Standard. A value of about 1.25 has been found in [3] from numerical simulations on the use of gas heat pumps in various residential buildings in the average European climate. Looking at the comparison from a life cycle assessment prospective [4], in renovated buildings and with the 2020 European energy mix, the weighted environmental impact of a gas absorption heat pump results about 25% lower than the one of a condensing boiler and about 50% lower than the one of electrical driven heat pumps.

In this work, the development of a gas driven absorption heat pump (GAHP) is presented, with a focus on the innovative solutions adopted to meet the goal of efficient and safe operation over the entire working range. Three technical solutions are presented, i.e., the so-called "booster" function, the use of a double restrictor in the solution branch and the use of an innovative approach to defrosting.

Gas fired absorption heat pumps experience an increase of the temperature of the generator when the thermal lift (difference between source and supply water temperatures) and the capacity increases. Thus, traditionally, the thermodynamic cycle is designed to have the maximum temperature at the generator at the lowest outdoor air temperature, higher supply temperature and design capacity. Consequently, when the working conditions become more favorable, i.e., at lower lift and lower capacity, the temperature of the generator decreases. This has two main consequences. The first is that at very low load conditions the temperature of the generator may become sub-optimal or even decrease below the cut-off limit [5]. The second is that at mild conditions the heat pump results strongly oversized, leading to a poor efficiency and unfavorable weight to power ratio. To overcome these issues the innovative solutions have been implemented. The booster is a patented [6] solution, which allows to reduce the generator temperature at high capacity and high thermal lift. This permits a design of the cycle with a more favorable weight to power ratio, keeping the capability to provide the nominal capacity at design conditions, while maximizing the efficiency at intermediate lift and capacity, i.e., in those conditions when most of the yearly energy is delivered.

The use of a double restrictor allows a better tuning of the generator temperature across the working range, with further benefits on the efficiency.

The third innovative solution introduced in the heat pump concerns the defrosting operation, required to remove the ice layer which builds up on the air-sourced evaporator of all heat pumps. While in vapor compression heat pumps this is usually done by inverting the thermodynamic cycle and operating the evaporator as a condenser, allowing the hot refrigerant to melt the ice, in absorption heat pump the most common solution relies on a bypass of hot refrigerant from the generator to the evaporator, skipping the condenser. The cycle inversion of Vapor Compression HPs has a significant impact on the thermodynamic cycle and on the continuity of the power delivered to the user. The bypass of refrigerant usually implemented in GAHPs is less impacting but affects for a certain period the operation of the cycle and require a fine design of the internal volumes. For the developed heat pump an alternative approach has been selected, taking advantage of the use of an indirect evaporator: a heat exchanger is used to heat up the secondary fluid which circulates in the air-sourced heat exchanger using the supply water. In this work this system is described and details about its operation are provided.

2. Concept description

The Ariston Group initiative on Thermally Driven Heat Pumps focused on a common thermodynamic design that could serve a range of products to accommodate the need of the different local market in which the Group is commercially active. The design of the technological solution was therefore targeted to support different capacity ranges and aeraulic design and installation configurations.

First of all, the thermodynamic design was conceived in order to incorporate products with different capacity range. Indeed, the destination markets include different heat loads due to the different size and different insulation characteristics of the buildings. Therefore, to cover the largest possible portion of the European residential market, the sealed circuit was designed to be able to accommodate an output power in the range from 8 kW to 15 kW measured at air temperature of -22 °C and supply water of 70 °C.

Similarly, the different local market features and the different requirements in terms of expectation for quietness (with the associated legislation) resulted in product design solutions to be customized for such markets. Indeed, in several countries the noise limits are differentiated between day and night, with expectations for extremely low noise performance at night and in proximity to the fence or window of the neighborhood. Therefore, two different aeraulic designs, depicted in Figure 1, have been developed to accommodate the most differentiated acoustic emission targets and the requirements of markets where the form factor and total volume were highly valued. This mass customization approach was implemented in a platform design of the thermodynamics and in two set of aeraulic configurations (horizontal and vertical air flow) with substantially differentiated fans and air heat exchangers.



Fig. 1 – The two aeraulic configuration developed to meet the requirements of the different European markets.

Finally, the specific requirements of the local European market were translated in several options for possible installation configurations. Indeed, the compactness, local regulation on exhaust flue gas, resilience to extreme weather conditions generated different evaporator designs. In details, Ariston developed a technology platform where several features could be incorporated to maximize the customization to the

different markets. Among others, this approach included several unique features for a thermally driven heat pump as described in the following.

- Air sourced design with indirect evaporator: the evaporation of the refrigerant happens in a heat exchanger with a water-glycol mixture. This fluid is then used to exchange with outdoor air by means of an air coil. This design allows lower ammonia content, and an almost transparent defrosting cycle actuation.
- Combustion system designed and tested to comply with both current gases and expected new green gases (Bio LPG, Bio-methane, H₂ blend). This feature allows the end-user to perceive the investment in the TDHP technology as something already designed for the future gases that will be injected in the grid.
- Design solutions for industrialization of pumping system, heat exchangers and solution desorber to allow high quality and high-volume manufacturing.

Similarly, the control architecture was developed to include:

- a sophisticated on-board controller able to control the appliance safety and efficient heat generation function,
- a plant controller to control most possible installation schematics used in the destination markets,
- remote access, and connectivity functions to allow functionality and performance monitoring,
- access to the entire ecosystem of accessories that the Ariston Group offers.

In this section, the technological features which have been incorporated in the heat pump to meet the mentioned level of flexibility, efficiency and quietness will be presented.

2.1. Booster

Heat pumps usually experience a performance reduction at high thermal lift, i.e. when the outdoor air temperature is low and when the supply water temperature is high. Therefore, heat pumps result undersized when the heating demand of the building is higher and require a backup system (electrical resistance or gas boiler) which increases the system complexity and cost and reduces the overall efficiency. Alternatively, if the heat pump is sized to handle the full load at design condition, it results largely oversized when the load is lower, i.e. for most of the heating season, again with negative impact on the costs and on the efficiency.

To overcome this issue, the booster concept [6] is aimed at allowing a gas input above the nominal value, while keeping the generator temperature below the maximum value, usually set at 180-200 °C for corrosion control reasons. The booster concept relies on two splits on the solution and the refrigerant circuit aimed at modifying the magnitude of the internal heat recoveries, with the purpose of lowering the temperature and increasing the ammonia mass fraction of the rich solution entering the generator. This has the effect of reducing the temperature in the generator and increasing the maximum amount of gas input.

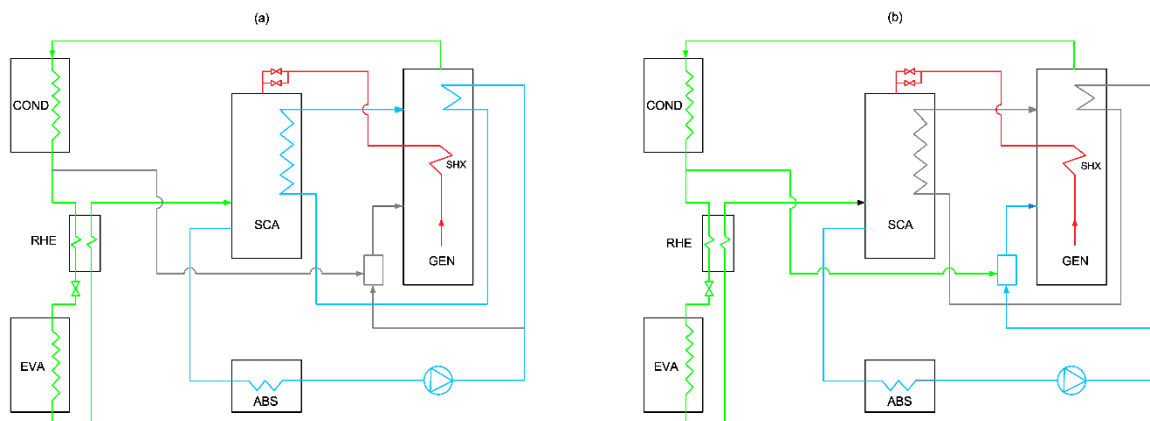

Fig. 2 – scheme of the heat pump cycle during normal operation (a) and with activated booster function (b).

With reference to Figure 2, where the cycle layout is presented both under normal operation (a) and in booster mode (b), the solution which normally flows through the Solution Cooled Absorber (SCA) is deviated and directly sent to the generator, disabling the heat recovery given by the GAX (Generator Absorber heat eXchange) effect. Moreover, making use of a venturi tube, part of the refrigerant leaving the condenser is injected in the rich solution, increasing its ammonia mass fraction. This increases the mass fraction in the generator and its capability to generate vapor, transferring the extra gas input into latent energy. The possibility

to increase the gas input up to 50% more than the design value permits to reach the maximum heating capacity even when the thermal lift is high. Thus, the thermodynamic cycle can be sized to operate with the maximum efficiency in the most frequent conditions, i.e., intermediate thermal lift and load, while keeping the possibility to meet the maximum capacity without the need of auxiliary systems.

A further effect of the activation of the booster is the reduction of the high pressure of the cycle. In fact, when the rich solution is directly routed towards the generator, the rectifier is not cooled anymore. This results in a lower mass fraction of the refrigerant leaving the generator, which causes a reduction of the condensation temperature. This is often beneficial since the booster is usually activated at high supply temperatures, which are also associated to high pressures. Thus, the booster can be used not only to deliver the required capacity without exceeding the maximum temperature at the generator, but also to increase the supply water temperature while keeping the maximum pressure within the design limits.

2.2. Two-stage restrictor

To further extend the capability of the heat pump to operate efficiently in all the loads and thermal lifts, a double stage restrictor has been used on the poor solution branch. The control of the flow rate on the solution branch consent to deal with two well-known correlated issues related to part load operation of gas driven heat pumps, i.e., the reduction of the temperature in the generator and a sub-optimal ammonia mass fraction in the circuit. In fact, gas driven heat pumps deal with part load by reducing the gas input. This automatically translate in a reduction of the generator temperature and a consequent increase of the ammonia mass fraction of the solution contained in the generator volume. These changes have various effects: they reduce the concentration spread between the rich and poor solutions (which impacts on the GAX effect in the SCA) and reduce the amount of ammonia available for the other components. The first issue has a direct impact on the efficiency of the heat pump and can even lead to cut-off conditions when the generator temperature decreases too much, forcing the control system to run the machine in an inefficient on-off operation. The second issue has an impact on the low pressure, which tends to decrease when the amount of ammonia available in the circuit is not sufficient, with a negative impact on the efficiency of the heat pump, which operates in an unnecessary artificially high thermal lift.

The use of a variable solution flow rate to maintain the generator temperature in its optimal value and to maximize the heat pump efficiencies in all the thermal lift and load condition has been proved numerically [5]. In this work, the concept has been deployed in the developed heat pump, opting for a two-stage restrictor instead of a continuously adjustable one to keep the cost and control complexity low. However, through a proper selection of the characteristic of the two restriction stages and in combination with the booster, it has been possible to maintain a high efficiency in the entire range of operating conditions.

2.3. Defrosting

The choice of an indirect evaporation allowed the design of an innovative approach to defrosting operation.

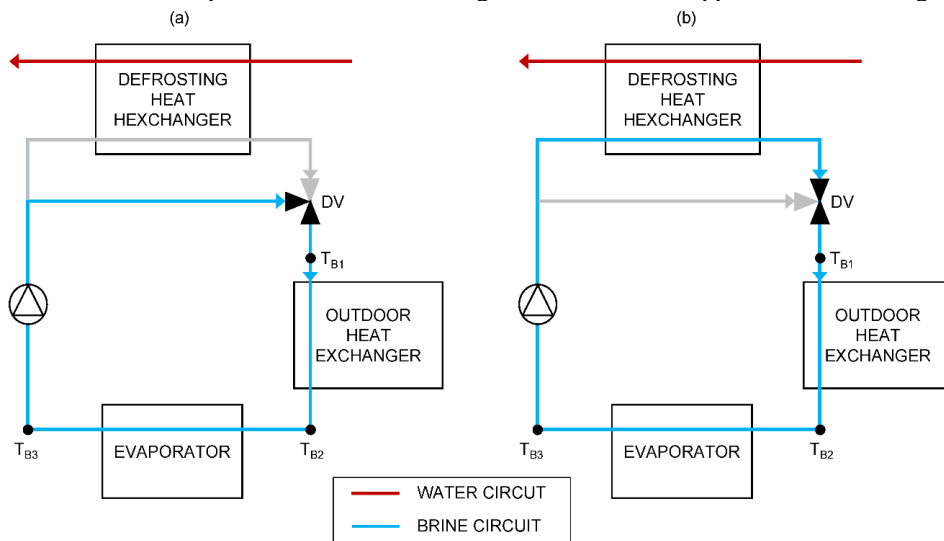

Fig. 3. Schematic representation of the defrosting system during normal operation (a) and defrosting operation (b).

With this system, which schematic operation is reported in Figure 3, the defrosting process is done by heating up the brine in the secondary circuit by means of a heat exchanger, called defrosting heat exchanger, paced in series with the supply water outlet. During normal operation (Figure 3a) the three-way valve DV allows the brine to circulate between the evaporator and the outdoor air heat exchanger, skipping the defrosting heat exchanger through the brine bypass. During defrosting operation (Figure 3b) the valve switches, closing the brine bypass and circulating the brine through the defrosting heat exchanger. Here the brine is heated up by the supply water, reaching a temperature warm enough to defrost the air-sourced heat exchanger.

3. Performances

In this section the measured performances of an initial prototype of a heat pump are presented. A first defrosting operation is reported to prove the effectiveness of the developed solution. Then, the effects of the booster and of the double restrictor on the thermodynamic cycle are showed with reference to some specific tests. Finally, the seasonal performance according to the European Standard EN 12309 and the representation of the operating range of a prototype of a heat pump incorporating the described solutions are reported.

3.1. Defrosting

The relevant temperatures useful to analyze a defrosting operation are reported in Figure 4. In particular, the black line indicates when the defrosting valve DV is opened (at time 18:42) and closed (at about 18:45). In the first part of the chart, the temperatures of the brine entering (T_{B1}) and leaving (T_{B2}) the outdoor air sourced heat exchanger are about $-10\text{ }^{\circ}\text{C}$ and $-13\text{ }^{\circ}\text{C}$, significantly lower than the air temperature ($0\text{ }^{\circ}\text{C}$) due to the presence of frost, while the supply water temperature is stable at $55\text{ }^{\circ}\text{C}$. When the defrosting operation starts, the brine passes through the defrosting heat exchanger and meets the warm water leaving the heat pump. As a result, the temperature of the brine entering the outdoor air heat exchanger (T_{B1}) increases up to a level sufficient to melt the ice. The increase of the temperature of the brine leaving the outdoor air heat exchanger (T_{B2}) is slower due to the intense heat transfer taking place during the melting process. When the process is concluded by the return of the defrosting valve to its initial position, the supply water temperature reaches immediately the original value of $55\text{ }^{\circ}\text{C}$. The brine temperatures decrease more slowly due to the capacity of the circuit and of the outdoor heat exchanger, meaning that part of the sensible energy used to heat up the system at the beginning of the defrosting process is recovered. After the transient, the brine temperature stabilize few degrees below the air temperature, at the typical value associated to a frost-free heat exchanger.

The entire process lasts about 3 minutes and does not have any impact on the thermodynamic cycle. This makes the operation very efficient and allows to restore the supply temperature to its set value immediately. The basic principle herein described is subject to further improvements and it is associated to control features covered by industrial intellectual property of Ariston Group that include additional function for the management of the indirect evaporation and the defrosting.

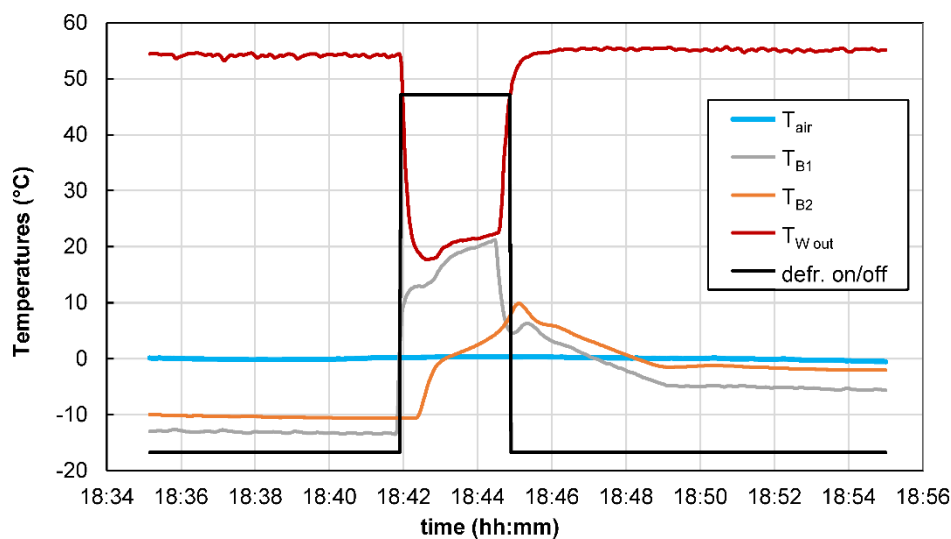

Fig. 4. Trend of the relevant variables of the brine circuit during a defrosting operation

3.2. Effects of the booster

As mentioned in the previous section, the booster can be used for two different purposes, i.e., limiting the generator temperature at high capacity and high thermal lift or limiting the high pressure at high supply temperature. In the chart in Figure 5 the effect of the booster on the cycle when it is used to limit the high pressure can be observed. The test was run at 20 °C of air temperature, while the water inlet/outlet temperature was 50/70 °C. Under this condition the high pressure was the limiting factor to the delivered capacity, which was about 3.6 kW (green line). To increase the heating power without a further increase of the high pressure, the booster was activated at 15:28. As a result, the generator temperature (red line) dropped from 143 °C to 133 °C and the high pressure (blue line) from 25 bar to 22 bar, creating some space for an increase of the gas input and of the delivered capacity. From the chart it is also possible to see that even if the activation of the booster introduces significant variations on the operation of the cycle, the transition is very smooth and does not impact the heat pump stability.

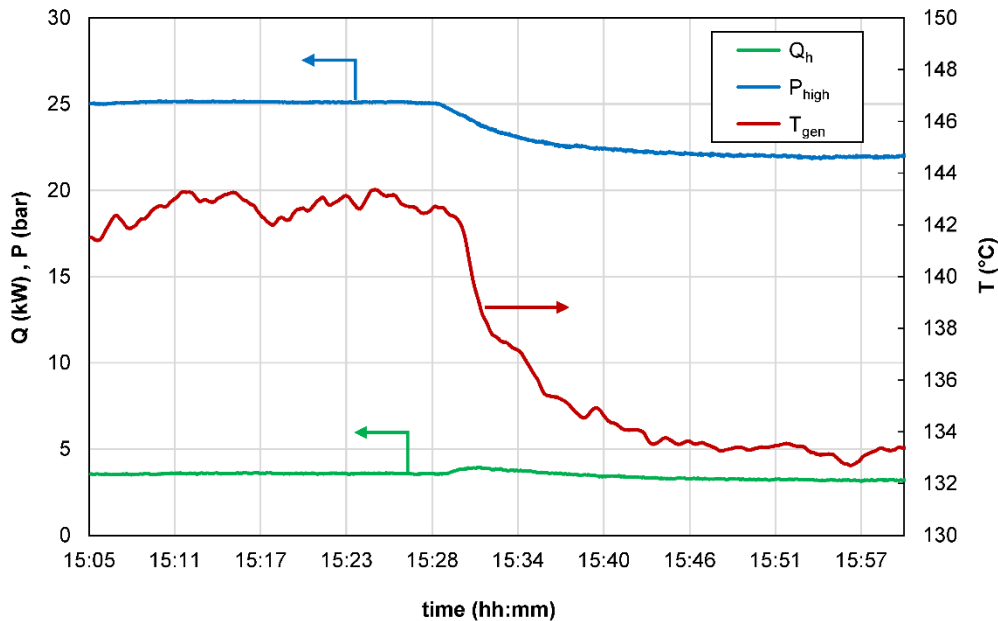

Fig. 5. Effect of the activation of the booster on the generator temperature and

3.3. Effects of the double restrictor

Providing a complete picture about the use of the double restrictor in combination with the booster is complex and would require the disclosure of control strategies that have been specifically developed to maximize the benefits of these solutions and are considered confidential. However, in this section the impact on the thermodynamic cycle of the switch between the two restrictors configurations is described showing the variation of some relevant quantities. In Table 1 the two pressure levels of the cycle, the temperature in the generator, the gas input, the delivered heating capacity and the resulting GUE are reported for the operation with slow and fast restrictor, for two operating conditions. Of the two reported conditions, the first, with air at 0 °C and water temperature of 40/55 °C, has been selected because it shows an efficiency independent on the type of restrictor used. On the other hand, for the second conditions, characterized by a lower thermal lift, a higher efficiency is found with the slow restrictor, which allows for a higher generator temperature.

The two reported conditions allow the use of both the restrictors because they are characterized by an intermediate heating capacity (about 63% of the nominal capacity) and intermediate thermal lift. As the capacity and the lift increase, the fast restrictor becomes the only option available since the slow restrictor would lead to excessively high temperatures in the generator. On the other hand, at lower capacities and lower thermal lift, the slow restrictor is the only available alternative because with the fast restrictor the temperature of the generator would drop and lead to very low efficiency or even to cut-off conditions.

Table 1. Impact of the type of restrictor on the thermodynamic cycle

		$T_{\text{air}} = 0 \text{ }^\circ\text{C}, T_w = 40/55 \text{ }^\circ\text{C}$		$T_{\text{air}} = 7 \text{ }^\circ\text{C}, T_w = 40/55 \text{ }^\circ\text{C}$	
		Slow restrictor	Fast restrictor	Slow restrictor	Fast restrictor
high pressure	bar	15.8	16.4	19.2	19.5
low pressure	bar	2.7	2.5	4.2	4.3
generator temperature	$^\circ\text{C}$	169.3	144.6	172.0	137.9
Q_{gas}	kW	5.24	5.47	4.32	4.43
Q_h	kW	6.33	6.63	6.26	6.27
GUE	-	1.21	1.21	1.45	1.42

3.4. SPER based on the EN 12309

The efficiency of a prototype of such a heat pump has been measured in a certified laboratory at Politecnico di Milano premises following the procedure proposed by the European Standard EN12309 [7]. The Standard gives the possibility to calculate the Seasonal Gas Utilization Efficiency (SGUE) for three different outdoor design temperatures (2 $^\circ\text{C}$, -10 $^\circ\text{C}$, and -22 $^\circ\text{C}$) corresponding to the three reference European climates warmer, average, and colder respectively. Moreover, for each climate, four different climatic curves are available, corresponding to different requirements of the emission system. For the present work, a design supply temperature of 55 $^\circ\text{C}$, corresponding to the high temperature application, has been selected and the results for the average climate conditions are presented.

To calculate the SGUE, the Standard approach considers the GUE, i.e., the ratio between the heating capacity of the heat pump and the gas input, at different load ratios. The Part Load Ratio (PLR), i.e. the ratio between the design and the actual building loads, is calculated as a function of the outdoor design temperature and the actual outdoor air temperature, under the assumption that the building load is proportional to the difference between the indoor and the outdoor temperature and becomes zero at 16 $^\circ\text{C}$.

The SGUE is calculated using the bin method as in Equation 1. The Standard prescribes to measure the GUE under the working conditions reported in Table 2 and to derive the values of GUE for the remaining air temperatures by interpolation. Since the performances of the GAHP are also affected by the return water temperature, the Standard allows a maximum temperature difference between supply and return temperature (ΔT_{max} in Equation 2), function of the outlet water temperature ($T_{w \text{ out}}$).

Besides the GUE, Table 2 reports the Auxiliary Energy Factor (AEF) for each measured condition, i.e., the ratio between the heating capacity and the electrical power required for the auxiliaries of the heat pump, namely electronics, blower, fan, water pump and solution pump. These values are used to calculate the Seasonal Auxiliary Energy Factor when the appliance is running (SAEF_{ON}) in a similar way as the one described to calculate the SGUE from the GUE. Adding the electrical consumption in standby mode (E_{SB}) and thermostat off mode (E_{TO}), equal to 6 W and 0 W respectively, the SAEF is obtained. As last step, weighing the GUE and the SAEF with their corresponding primary energy factors ($f_{\text{EL}} = 2.5$ and $F_{\text{GAS}} = 1$), the Seasonal Primary Energy Ratio is calculated as in Eq. 3.

The following seasonal figures have been obtained for the developed heat pump:

- GUE_{NCV}: 1.50
- SAEF: 55.9
- SPER: 1.27

$$SGUE = \frac{\sum_{j=1}^N h_j \cdot \dot{Q}_h(T_j)}{\sum_{j=1}^N h_j \cdot \frac{\dot{Q}_h(T_j)}{GUE(T_j)}} \quad (1)$$

$$\Delta T_{\text{max}} = 7 + \frac{T_{w, \text{out}} - 35}{3} \quad (2)$$

$$SPER = \frac{1}{\frac{f_{\text{GAS}}}{SGUE} + \frac{f_{\text{EL}}}{SAEF}} \quad (3)$$

Table 2. Test conditions and measured GUE and AEF.

part load ratio	T_{air} (°C)	T_{air}^{WB} (°C)	$T_{w out}$ (°C)	$T_{w in}$ (°C)	GUE_{NCV}	AEF
100%	-10	-11	55.0	41.4	1.26	50.0
88%	-7	-8	52.0	39.4	1.33	53.0
54%	2	1	42.0	32.7	1.53	61.1
35%	7	6	36.0	28.7	1.61	59.8
15%	12	11	30.0	24.7	1.38	35.3

It must be mentioned that the test conditions reported in Table 2 have been run without activating the booster. This is due to the design choices, which aimed at delivering the design power at the design condition without the need of activating the booster, with the scope of assuring high efficiency over the space heating conditions. However, the booster can be activated when the outdoor temperature drops below the design conditions or when high water temperatures are required (e.g., during the domestic hot water preparation). Additionally, the booster operation is also influenced by the gas input, which impacts on the generator temperature. In the following section a rough indication about the conditions when the booster is needed is presented.

3.5. Operating range

Gas absorption heat pump is a technology which could be asked to operate over a very wide range of operating conditions. In fact, being the existing building its more natural application, the type of emission system and capacity requirements can differ significantly from case to case. Additionally, existing buildings can present high load and the need for high supply temperature in all type of climate conditions. The innovations described in the previous sections, beside enabling high performances, were introduced also to extend the operating range of the heat pump, to maximize the possible application that can be addressed with the same design. As a result, the described heat pump prototype can provide 70 °C of supply water with air temperature from -22 °C, i.e., the design condition of the reference European colder climate conditions to above 30 °C, typical of the summer season when domestic hot water production is still required. As reported in Figure 6, when the design capacity is required, supply temperatures above 55 °C and air temperatures below -15 °C require the activation of the booster. This region becomes smaller at the minimum capacity, where only the upper part of the supply temperature range requires the activation of the booster. The limitation existing at the combination of high air temperature and high supply temperature is given by the high pressure, which would exceed the design values.

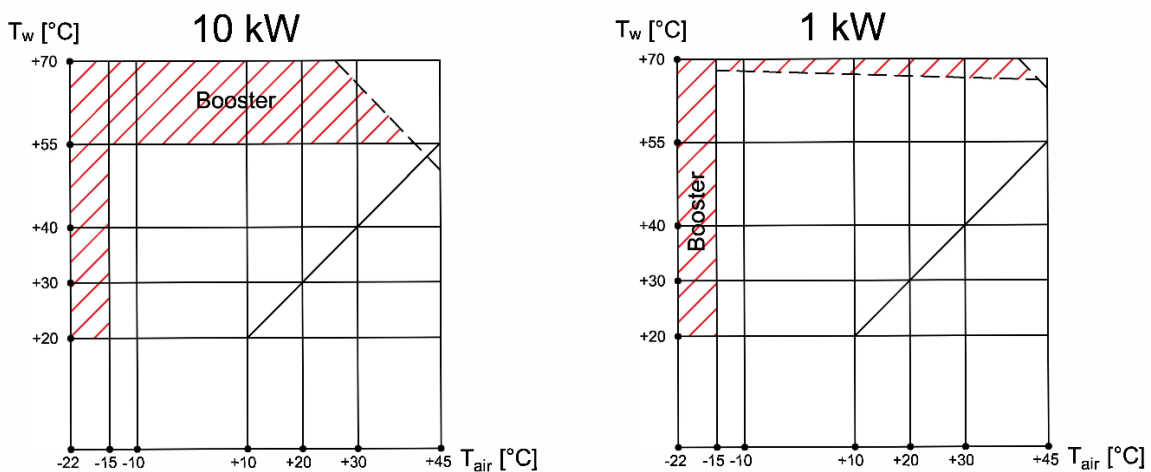

Fig. 6. Graphical representation of the operating range of a 10-kW heat pump at maximum and minimum capacity

1. Conclusions

In this work the development of a prototype of a new product platform of gas absorption heat pumps for residential application has been presented. The main innovations introduced, their motivation and their impact on the heat pump operation have been described.

An innovative defrosting system has been developed, taking advantage of the use of an indirect evaporation configuration, with a brine auxiliary circuit. This system resulted very effective and able to complete the defrosting operation in about three minutes, with minimal impact on the user and no influence on the thermodynamic cycle.

The combined use of the patented concept of the booster and of a double stage restrictor allows the heat pump to operate from -22 °C to more than 30 °C of air temperature, with maximum supply temperature of 70 °C. It also made it possible to design the thermodynamic cycle to reach the maximum efficiency in the most frequent operating conditions in the heating season and to avoid the oversizing of the heat pump, keeping the dimensions and the weight low. Moreover, these solutions enabled efficient operation over the entire operating range, which resulted in a Seasonal Primary Energy Ratio measured according to the European Standard EN 12309 of 1.27 and a Seasonal Auxiliary Energy Factor of 55.9.

From this initial development work, Ariston completed the design of a new platform of TDHP products further enhancing these results.

Acknowledgements

The development of the gas absorption heat pump presented in this work has been done within the i-GAP research project, supported under the Call “Agreements for Research and Innovation of the Lombardy Region” co-financed by the ERDF ROP 2014-2020 of the European Commission. Project ID: 241736. Moreover, the introduction of the double restrictor and the extension of the modulation range has been funded by Regione Lombardia under the LombHe@t Project - Call Hub Ricerca e Innovazione. These developments are therefore the basis of a scientific and technological work that Ariston Group has considered in preparing its new TDHP platform.

References

- [1] W. Eichhammer, T. Fleiter, B. Schlomann, S. Faberi, M. Fioretto, N. Piccioni, S. Lechtenböhrer, A. Schüring, V. Resch, *Study on the Energy Savings Potentials in EU Member States, Candidate Countries and EEA Countries*, Final report, 2009.
- [2] M. Garrabrant, R. Stout, C. Keinath, and P. Glanville, *Experimental Evaluation of Low-Cost Gas Heat Pump Prototypes for Building Space Heating*, 16th International Refrigeration and Air Conditioning Conference, Jun. 2016. [Online]. Available at: <http://docs.lib.purdue.edu/iracc/1573>
- [3] R. Scoccia, T. Toppi, M. Aprile, M. Motta, *Absorption and compression heat pump systems for space heating and DHW in European buildings: Energy, environmental and economic analysis*. *Journal of Building Engineering* 2018;16:94-105.
- [4] J. Famiglietti, T. Toppi, D. Bonalumi, M. Motta, *Heat pumps for space heating and domestic hot water production in residential buildings, an environmental comparison in a present and future scenario*, *Energy Conversion and Management*, 2023; 276: 116527.
- [6] Marco Guerra, *Absorption heat pump for overfeed generator operating conditions*, Patent application EP2372273B1/ US8950212B2, 2011.
- [5] Giorgio Villa, Tommaso Toppi, Marcello Aprile, Mario Motta, *Performance improvement of gas-driven absorption heat pumps by controlling the flow rate in the solution branch*, *International Journal of Refrigeration* 2023; 145:290-300.
- [7] European standard, *EN12309:2014, Gas-fired sorption appliances for heating and/or cooling with a net heat input not exceeding 70kW*.