



14th IEA Heat Pump Conference
15-18 May 2023, Chicago, Illinois

A novel oscillatory thermal response test for deep U-tube borehole heat exchanger: In situ data

Ahmed A. Serageldin^{a,b}, Nagano Katsunori^a

^aDivision of Human Environmental Systems, Faculty of Engineering, Hokkaido University, Sapporo, 060-8628, Japan

^bDepartment of Mechanical Engineering, Shoubra Faculty of Engineering, Benha University, Cairo, 11629, Egypt

Abstract

The current study proposed a novel thermal response test methodology to minimize the testing time, and save labor time and testing cost; it utilizes an oscillatory heat flux called OscTRT. The oscillating heating flux has the shape of a sinusoidal wave with a frequency of 1.74×10^{-3} Hz, an average value of 14 kW, and an amplitude of ± 6 kW. A new TRT machine is customized to control the heating injection pattern frequency and amplitude. Five OTRTs are conducted at sites with various geological and hydrological conditions with an apparent thermal conductivity range of 1.2 ~ 3.1 W/m.K. The sites are located in Sapporo city, Niseko city in Hokkaido prefecture, Miyoshi city in Hiroshima prefecture, Kai city in Yamanashi prefecture, and Tokyo city in Japan. All sites' borehole depths and diameters are 300 m and 250 mm. The fluid temperature and soil undisturbed temperature profiles are measured using optical fiber cables inserted inside the U-tube legs. While, A new analysis method is presented to filter, smooth, and fit the recorded data to find the response temperature amplitude at inlet and outlet to the borehole. The borehole and subsurface thermal response are analyzed to find the amplitude ratio, phase shift angle between inlet and outlet temperature responses, and effective thermal conductivity. The accuracy and validity of the proposed method are examined by comparing the output with the results from the conventional TRTs. Five OscTRTs are carried out for 24 hours, while the normal TRTs are conducted for 60 hours. The results show that the OscTRT shortened the time needed for TRT by 60% with high accuracy. Also, a linear relationship between the amplitude ratio and effective thermal conductivity is derived.

© HPC2023.

Selection and/or peer-review under the responsibility of the organizers of the 14th IEA Heat Pump Conference 2023.

Keywords: Thermal response test; Oscillatory thermal response test, Ground source heat pumps, Effective thermal conductivity ;

1. Introduction

Ground source heat pump systems (GSHPs) for subsurface heat utilization have recently developed due to their energy saving, high efficiency, and no pollutant emission[1]. The local soil's thermal parameters must be first known when designing GSHPs. The thermal conductivity of the ground (λ) and thermal resistance (R_b) of the ground heat exchanger (GHE) are the two most important design parameters for borehole thermal energy storage (BTES) systems[2]. An in-situ thermal response test (TRT) may determine these two parameters, which gives reliable design data. The common TRT includes boreholes, fluid circulation, temperature control devices, and data acquisition instruments. Temperature sensors are installed at the inlet and outlet of the GHE to measure the average temperature of the circulating fluid. Many portable test devices are small in size and easy to operate[3]. The first step of the test is to determine the undisturbed ground temperature, This is usually made by temperature logging in the borehole or by evaluating the fluid temperature of the circulating fluid before the heating/cooling is switched on. The fluid inlet and outlet temperatures are measured by Pt 100 sensors, while a magnetic flow meter measures the fluid flow rate. The flowing fluid is heated using an electrical heater with 5-10 kW. A data logger records all the data for 48 to 72 hours with a time interval of 30 seconds or 60 seconds[4]. Using the basic theory of heat transfer, the relationship between the average temperature of circulating fluid and the temperature of the borehole wall can be expressed as shown in Eq. (1):

$$q = \frac{\bar{T}(\tau) - T_b(\tau)}{R_b} \quad (1)$$

Where q is the heating injected heat per meter, W/m; \bar{T} is the average fluid temperature, K; T_b is the temperature of the borehole, K; τ is the test time, sec.; R_b is the borehole thermal resistance (m.K)/W; it includes the convection thermal resistance from the fluid to the inner tube surface ($R_{conv.}$), the conduction thermal resistance of the pipe material (R_p), and the conduction thermal resistance through the grouting material[5]. This equation is conditioned to the minimum test time to affirm the steady state of heat transfer inside the borehole and neglect the unsteady heat transfer period. Therefore, the test time $\tau > 10\tau_b$ [6] where τ_b is calculated according to Eq. (2)

$$\tau_b = \frac{r_b^2}{a_g} \quad (2)$$

Where r_b is the borehole radius, m, and a_g is the grouting material thermal diffusivity, m²/s. Due to the complexity of solving the theoretical basis for the heat transfer analysis outside the borehole, the Boltzmann transformation is used to obtain the mathematical expression of the approximate infinite line source (ILS) model. The average fluid temperature is expressed as indicated in Eq. (3)

$$\bar{T}(\tau) = \frac{q}{4\pi\lambda_s} \ln(\tau) + q \left[R_b + \frac{1}{4\pi\lambda_s} \left(\ln \frac{4a_s\tau}{r_b^2} - \gamma \right) \right] + T_g \quad (3)$$

where T_g is the undisturbed soil temperature, K, a_s is the thermal diffusivity of soil, m²/s; γ is the Euler's Constant (0.5772 [-]).

Ingerson et al., in 1984, developed the infinite cylindrical source model (ICS) to consider the radial heat transfer through the borehole. While many improved models were developed to describe the heat transfer process more accurately, like the finite line source (FLS) by Zeng et al. in 2002[7], the infinite moving line source model (MILS) [8] and moving finite line source model (MFLS)[9].

Based on the ILS model, the linear regression method takes advantage of the linear relationship between the average inlet and outlet temperature of GHE and the logarithm of test time. Soil thermal conductivity can be obtained according to the fitting curve's slope. The borehole's thermal resistance can be obtained according to the identified thermal conductivity, as calculated from Eq. (4) and Eq.(5).

$$\lambda_s = \frac{q}{4\pi k} \quad (4)$$

$$R_b = \frac{1}{4\pi\lambda_s} \left[\frac{\bar{T} - T_g}{k} - \ln \left(\frac{4a_s\tau}{r_b^2} \right) + \gamma \right] \quad (5)$$

Based on the literature, all the TRT tests considered a constant heat injection through the borehole heat exchangers, and the test lasted for four days of continuous operation. To the author's best knowledge, very few researchers conducted a TRT test with a variable heat injection. Oberdorfer [10] proposed oscillatory injection rates for a short period (OTRT) instead of a constant step; he expected that the new methods could:

- Control and limit the investigation area by adjusting the oscillatory signal frequency.
- Extract additional information about the borehole and subsurface properties.

The heat injection rate is supposed to be a sinusoidal function with the amplitude P_1 and the angular frequency ω_0 . And a constant heat rate P_0 , which is larger than the oscillation amplitude, is added to the sinusoidal signal, as shown in Eq. (6)

$$P(t) = P_0 + P_1 \cdot \sin(\omega_0 t), \quad |P_0| > |P_1| \quad (6)$$

After carefully scanning the literature, we found that the TRT using oscillatory heating is not comprehensively investigated and is not yet matured. Therefore the current study will focus on advancing this method to predict the subsurface thermophysical properties precisely within a short test time and present the mature version of this new method.

2. Field test set-up

2.1. Borehole construction

The experimental investigation is conducted in five cities to experience various geological and thermal conditions in Hokkaido, Hiroshima, Yamanashi, and Tokyo prefectures in Japan, as shown in Fig (1a). At each site, conventional TRT, which applied a constant heating rate for 60 hours, and OTRT with an oscillatory heating rate for 24 hours are conducted. Each test is followed by a recovery period to affirm the full recovery of the subsurface’s thermal condition before the next test. During the drilling, soil samples at various depths are collected and identified accordingly at each site. Fig. (1b) depicts the geological layers associated with depth. The site in Niseko city has volcanic ash at the shallow depth and shall and tuff at the deep layer. Furthermore, the Miyoshi site shows a different profile containing only two layers; conglomerate in the shallow depth, and rhyolite rock occupies the rest of the depth. At last, Kai city is located on almost three layers; gravel, tuff, and sandy clay. The average depth thermal conductivity is 1.4, 1.2, 3.1, 2.1, and 1.6 W/m.K in Sapporo, Niseko, Miyoshi, Kai, and Tokyo cities.

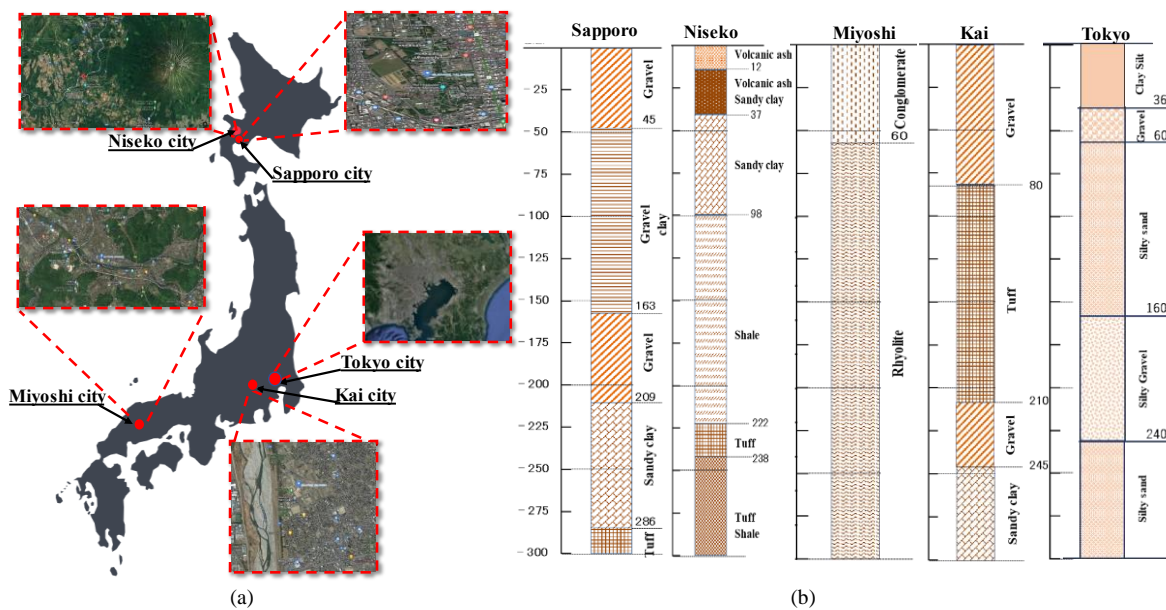

Fig. 1 Field study set-up, (a)Experimental sites locations, (b) Geological column in each site

Five boreholes with a depth of 300 m are drilled in 5 cities in Japan. Fluid based recirculatory method using mud rotary drilling with a rapid rotation speed is used in all sites except the Hiroshima site as shown in Fig(2a). A drilling head with a tricone bit with a diameter of 9” 7/8 inches is used to drill a borehole. While, In Hiroshima, downhole drilling with rotation and vibration is used because the geological column consists of only Rhyolit and Conglomerate rocks. Then A U-tube shown in Fig.(2b) is inserted in the borehole. The U-tube is made by the HakaGerodur company located in Switzerland. The U-tube is made of one unit of extruded Polyethylene PE100-RC (resistance to cracking) and polyamide PA12. Buckling pressure resistance is up to 43 bar, Probe lengths 200 to 410 m in rolls, as shown in Fig. (2b). The cross-section and specifications of the tube is shown in Fig.(2c) and listed in Table (1)

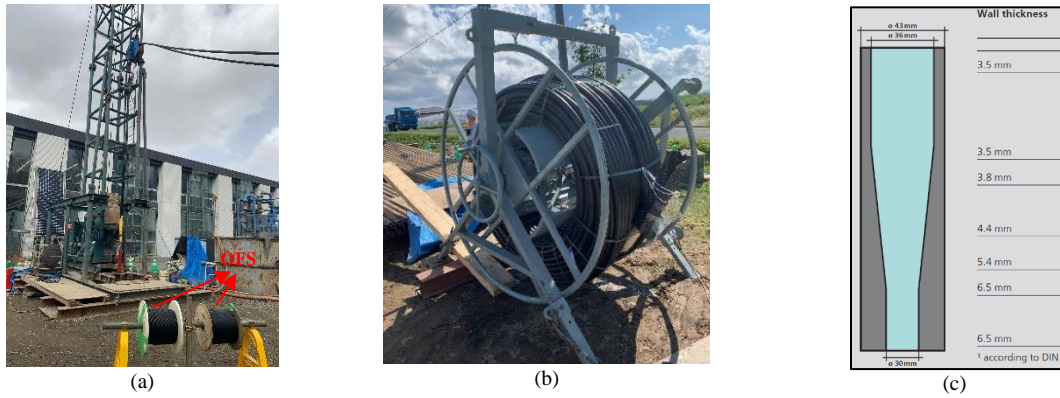

Fig. (2) Constructing the borehole heat exchanger steps (a) Drilling head, (b) U-tube heat exchanger, and (c) U-tube cross-section

Table (1) U-tube heat exchanger specifications

Parameter	Value	Units
Density	0.95-0.97	(g/cm ³)
Pipe roughness	0.03	(mm)
Thermal expansion	0.18	(mm/m.K)
Thermal conductivity	0.4	(W/m.K)
Specific thermal capacity	1.9	(J/g.K)

A pair of optical fiber sensors are inserted into the U-tube’s legs to measure the vertical temperature. Then the OFS is connected to the DTS instrument (made by Ap sensing in German). The temperatures are recorded every 0.5 m every 1 minute, and these results are used to calculate the heat transfer rate’s vertical profile and the vertical profile of the effective thermal conductivity. The specification of the DTS

2.2. Oscillatory Thermal Response Test Machine

A new TRT machine is customized and is equipped with a variable speed, three-phase, 200 V centrifugal pump with a power of 1.5 kW and a flow rate of 60 L/m (item No. 9) . Furthermore; the flow rate is controlled by changing the frequency via an inverter (item No. 11). The machine is also equipped with two single-phase electrical heaters connected in series with a total capacity of 20 kW (items No. 6 and 7) . Two three-phase thyristors power regulators control the electric energy supplied to these two heaters (items No. 12, 13). Moreover, a programmable adjusts the heating injection rate using the user interface and software (item No.

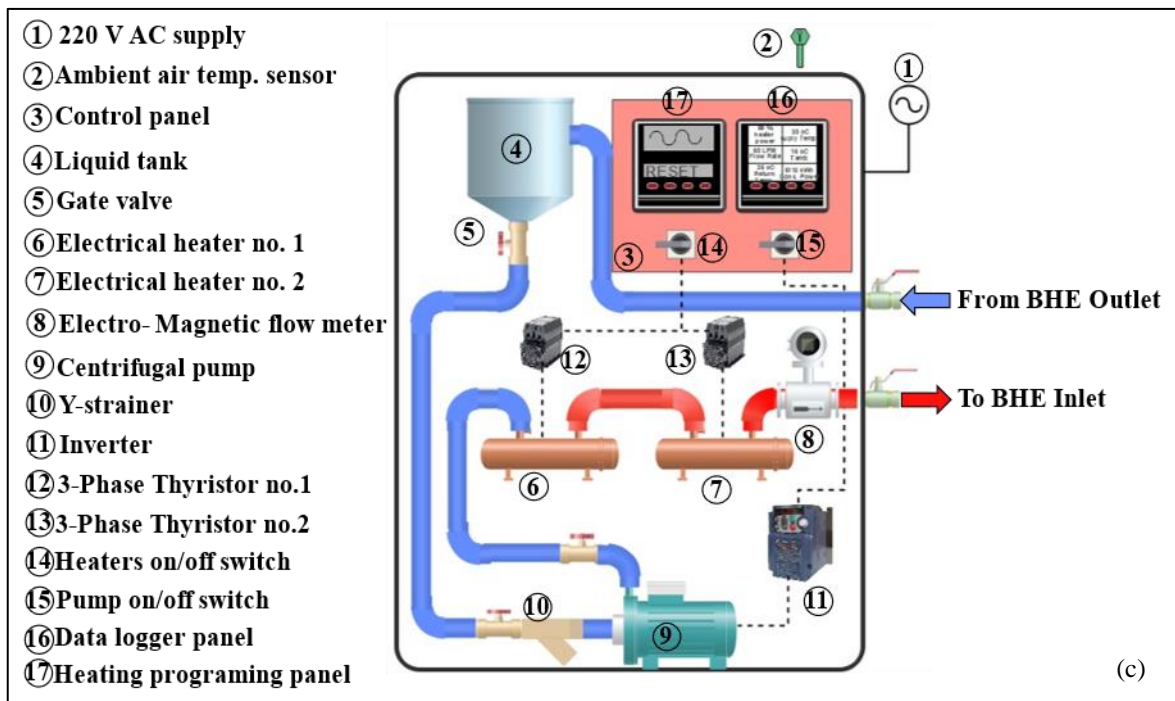

Fig. (3) left side shows The circuit diagram of the new TRT machine

17). An Electromagnetic flow meter is used to measure the fluid flow rate. A liquid tank (60 Litre) is used for liquid backup (item No. 4). These pieces of equipment are fixed inside a mobile carriage with dimensions of 930*1250*1580. Figure 3 illustrates the control panel and a mini data logger (item No. 16). This data logger records the fluid supply and returns temperatures, the ambient air temperature (item No. 2), fluid flow rate, heating power, and accumulated energy consumption. The schematic diagram presented in Fig. (3) explains the circuit diagram of the TRT machine.

2.3. Operation of the TRT test

After finalizing the set-up of the TRT machine, the operation procedure of the conventional TRT is summarized in the following steps:

- The pump is started to circulate the liquid (Ethylene glycol 40% in Sapporo and Niseko, and water in other locations) through the U-tube for 30 minutes to evacuate the air inside the U-tube.
- The flow rate measurement is observed to check the fluctuation until all the air inside the loop is expelled into the atmosphere. Once the flow rate becomes stable, this means the loop is free of any air bubbles and is ready to start heating and collecting the data.
- A constant heat rate of 20 kW(66 W/m) is injected into the BHE for 60 hours during the NTRT. While, The oscillatory heating wave is programmed by the software and transferred to the CHINO controller by means of a USB connection in the following form:

$$Q = q_{avg} + A \cdot \sin\left(\frac{2\pi t}{T}\right)$$
, as shown in Fig. (6b). The q_{avg} is 14 kW, the Amplitude A is ± 4 kW. and T is 1 hour.
- Supply and return fluid temperatures, flow rates, power injection, and fluid temperature distribution are instantly measured and recorded every 30 seconds.
- After the NTRT is continually operated for 60 hours and $O_{sc}TRT$ is continued for 24 hours, the heating and pumping are stopped,

while the soil temperature profile measurements are continued during the recovery period for two weeks

2.4. Analysis method

As explained earlier, the OscTRT is a superposition of constant heating and oscillatory heating with a certain amplitude and frequency. Therefore the new analysis method is proposed to decompose these two cycles and calculate the effective thermal conductivity from the constant heating part while calculating the amplitude ratio and phase shift from the oscillatory part.

The new analysis method includes two main steps; data processing and data analysis. The data processing steps are shown in Fig.(4). The steps are:

- 1- Inlet and outlet temperature measurements are filtered by using a Savitzky-Golay filter. And it is smoothed using a moving average of the elements using a fixed window length of 0.03 that is determined heuristically. The A Savitzky–Golay filter is a digital filter that can be applied to a set of digital data points to smooth the data.
- 2- Then the minimum and maximum peaks location and values of the filtered inlet and outlet temperatures data are determined and saved.
- 3- The average values of the maximum and minimum peaks are calculated.
- 4- The average values are subtracted from the filtered data to extract the oscillatory part.
- 5- The slope of the average values is calculated, then used to calculate the effective thermal (λ_{eff}) conductivity using Eq.(4)

The steps of data processing are summarized in Fig.(3)

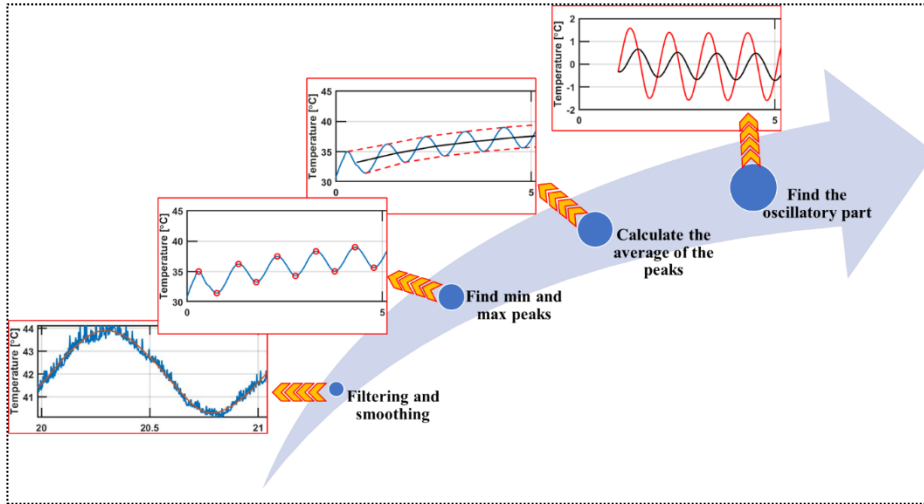

Fig.(4) workflow of data processing step

After the data is processed, the next step is data analysis to calculate the amplitude and phase shift angle of both inlet and outlet temperatures. The following procedure is proposed and depicted in Fig.(5):

- 1- Fitting the oscillatory part of the inlet and outlet temperature to the oscillatory function indicated in Eq.(7,8)

$$T_{in}(t) = A_{in,0} \cdot \sin(\omega_0 t + \varphi_{in}) \tag{7}$$

$$T_{out}(t) = A_{out,0} \cdot \sin(\omega_0 t + \varphi_{out}) \tag{8}$$

Where $A_{in,0}$, and $A_{out,0}$ are the amplitude of inlet and outlet temperatures (°C), ω_0 is the frequency (Hz), and φ_{in} and φ_{out} are the phase shift (sec).

- 2- Calculate the amplitude ratio between outlet and inlet temperature ($A_{out,0}/A_{in,0}$)
- 3- Calculate the phase shift lag between the outlet and inlet temperatures ($\varphi_{out} - \varphi_{in}$)
- 4- Find the relationship between the amplitude ratio ($A_{out,0}/A_{in,0}$) and the effective thermal conductivity (λ_{eff}). These steps are summarized in Fig.(8)

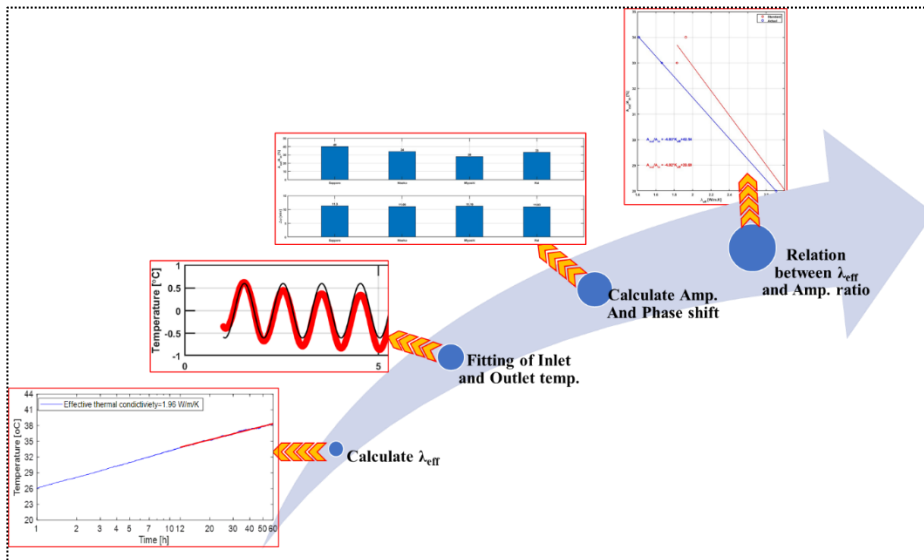

Fig. (5) Data analysis steps

3. Results and discussions

The following subsections indicate the results of the initial soil temperature profiles, the results of both the conventional TRT and OTRT, the fluid temperature profiles, the heat rate distribution profile, the effective thermal conductivity distribution profile, and the relationship between the amplitude ratio and the effective thermal conductivities.

3.1. Undisturbed soil temperature

The OFS measures the undisturbed soil temperature distribution profile before starting the TRT. It shows the natural soil temperature profile without any external disturbance. A comparison between these profiles is depicted in Fig. (6). Moreover, the soil surface temperature is affected by the energy balance on the soil surface at the test time. Generally, each profile also lists the temperature gradient for every 100 m. The Niseko site shows the highest temperature gradient of 10.9 °C /100 m, where the temperature reaches the value of 42 °C at the bottom of the borehole. This result shows a significant potential in this site which can be used for a direct heating system or hot spring applications. Meanwhile, the gradient is the lowest at the Tokyo site, with a value of 1.9 °C/100 m, where the temperature at the bottom of the borehole is 21 °C. Furthermore, the slope at Sapporo and Kai cities are similar, with values of 3.9 °C and 3.4 °C, respectively.

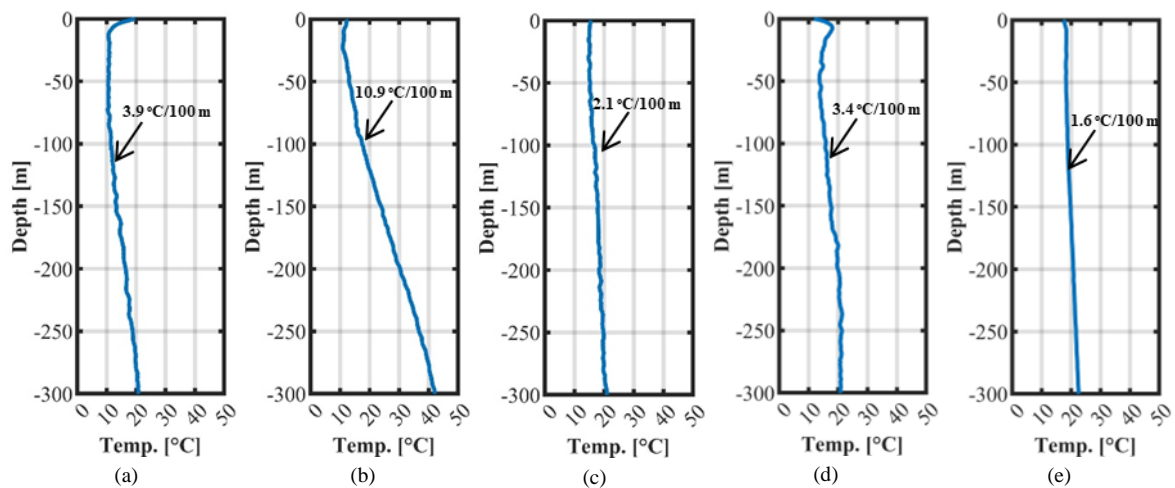

Fig.(6) Undisturbed soil temperature profile at a) Sapporo, b) Niseko, c) Miyoshi, d) Kai, and e) Tokyo cities

3.2. Conventional TRT

The inlet and outlet temperatures are recorded using PT100 sensors every two seconds. The flow rate and injected heat are recorded by the electromagnetic and power meters, respectively. The data are manipulated every 1 minute for 60 hours. The average fluid temperature is calculated, and the relation between the average fluid temperature and the logarithmic value of the time is depicted in Fig. (7). The figures indicate that the temperature increased with time, reaching a maximum value of 48 °C in Niseko city as shown in Fig. (7b). The heat transferred from the deep surrounding soil affects the fluid temperatures. The linear relationship through the period from 12~ 60 hours is developed. The slope of the linear relationship is used later to calculate the effective thermal conductivity in each city. The slope is varied from one city to another according to the geological and hydrological conditions in each site, the maximum slope in Niseko city reaches a value of 4.34 °C/hr and a minimum value of 1.79 °C/hr in Miyoshi city.

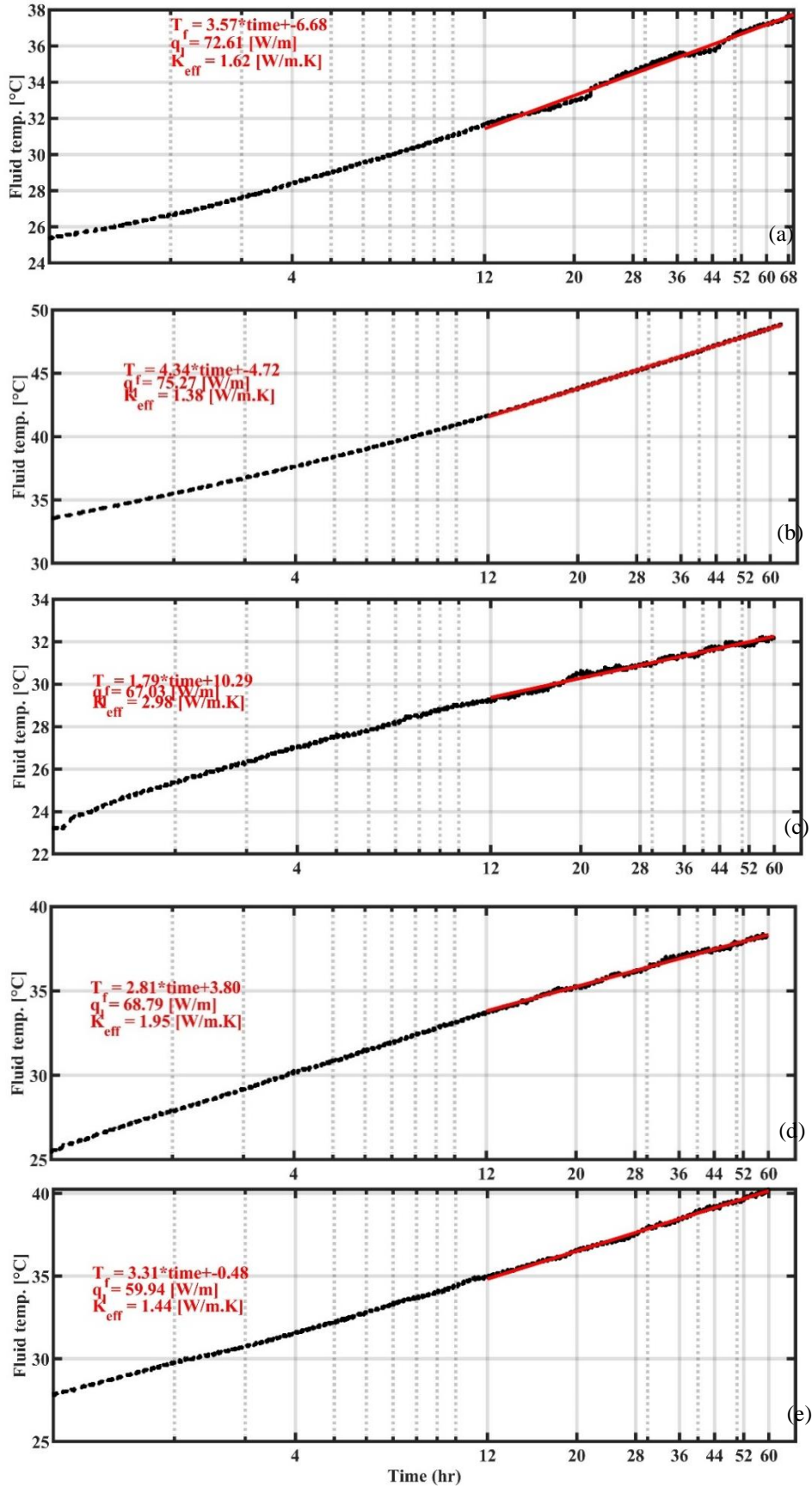

Fig. (7) The linear relationship between log time and T_f , (a) Sapporo, (b) Niseko, (b) Miyoshi, (c) Kai, (e) Tokyo cities

The calculated λ_{eff} are 1.62 W/m.K, 1.38 W/m.K, 2.98 W/m.K, 1.95 W/m.K, and 1.44 W/m.K in Sapporo, Niseko, Miyoshi, Kai, and Tokyo sites, respectively. Compared with the geological column, the error value is maximum in Kai city with a value of 50%, while the minimum value is achieved in Tokyo city. Therefore, these results show a possibility of groundwater flow impact on the measurement results in Kai city and need more investigation to assure this hypothesis.

Table (1) U-tube heat exchanger specifications

λ_{eff}	Sapporo	Niseko	Miyoshi	Kai	Tokyo
Geological column	1.4	1.2	3.1	1.3	1.46
NTRT	1.62	1.38	2.98	1.95	1.44
Error %	15.7	15	3.9	50	1.4

Two pairs of optical fiber sensors were inserted in each leg of the U-tube to measure the fluid temperature distribution every 0.5 m and record the measurements every minute, as depicted in Fig. (8). The results are reduced by averaging the temperature every 1 hour and 5 meters. Figure 8 depicts the fluid temperature profile every 10 hours. In Niseko city, the temperature at the bottom of the borehole has recorded the highest value of 47 °C. Also, the slope of the profile is almost straight through the depth of 180m to 300 m, because of the impact of the heat dissipated from the deep geothermal layer in this site. In comparison, Miyoshi shows the lowest temperature at the bottom edge of the borehole, with a temperature of 32 °C.

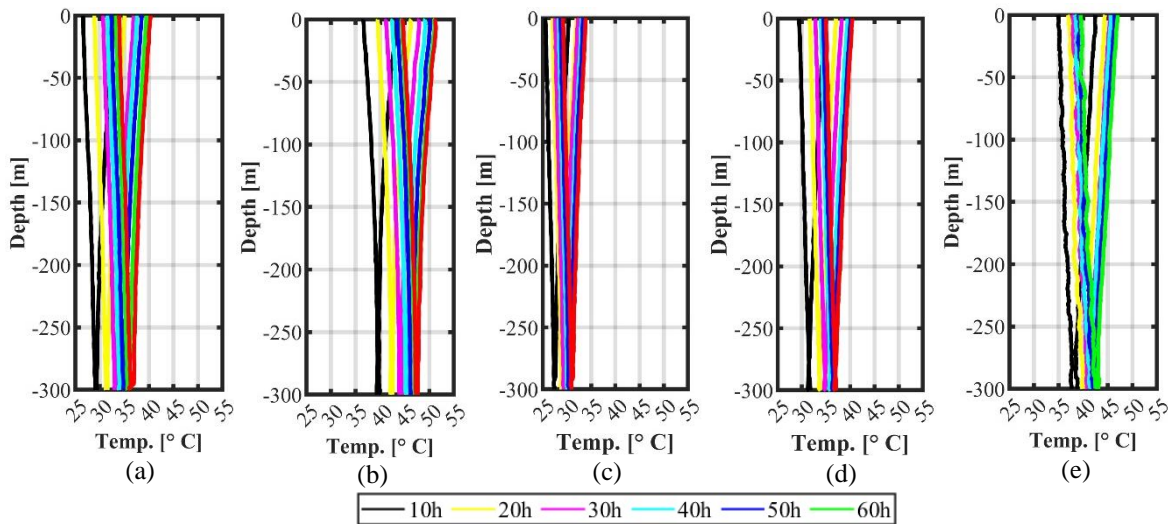
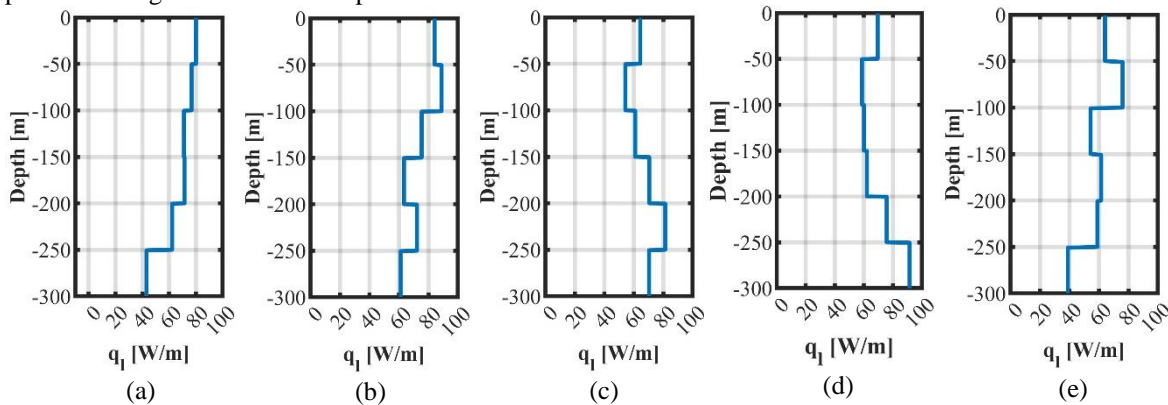

Fig.(8) Fluid temperature profile at a) Sapporo, b) Niseko, c) Miyoshi, d) Kai, and e) Tokyo cities at different time

Using the information of the flow rate and the temperature profile distribution in both DL and UL tubes, the vertical profile of the total heat transfer rate and effective thermal conductivity can be calculated, as shown in Fig. (9). Also, these results are represent the average values of 12 hr~ 60 hr. As a simplification, the depth is divided into 6 layers, but for more insight investigation, these results have to consider the precise calculation of the number of layers. Also, it is clear to define the layer with a potential of groundwater impact and further prediction of groundwater flow speed.



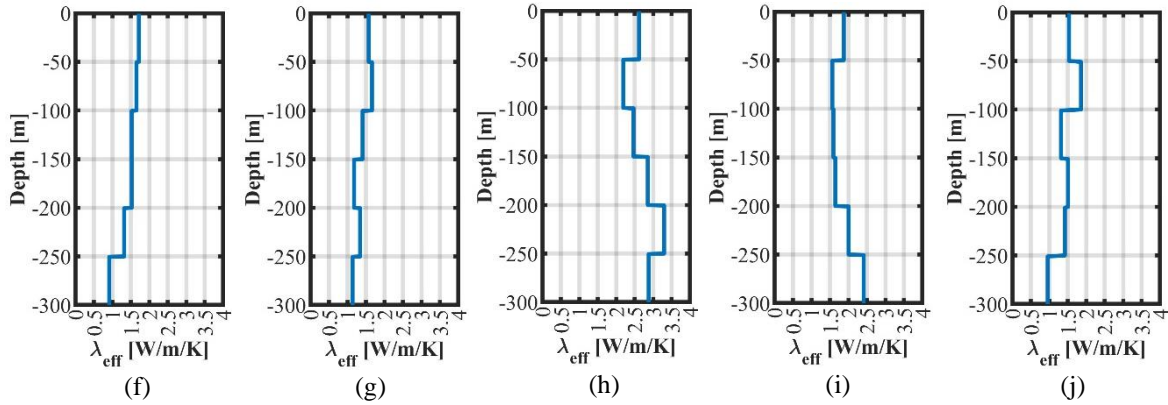

Fig.(7) Heat transfer rate profiles at a) Sapporo, b) Niseko, c) Miyoshi, d) Kai, and e) Tokyo cities, and thermal conductivity profile at f) Sapporo, g) Niseko, h) Miyoshi, i) Kai, and j) Tokyo cities

3.3. Oscillatory TRT

The inlet and outlet temperatures are recorded simultaneously with the flow rate measurement every two seconds. The measurements are filtered and smoothed, as shown in Fig.(A1a) in Appendix A. Then, the maximum and minimum peak location and values are determined, as shown in Fig.(A1b). Moreover, the average values of each inlet and outlet temperature, as well as the heating rate, are calculated as depicted in Fig. (A1c). The oscillating part of the signal is isolated by subtracting the average values from the original smoothed data, as indicated by Fig. (A1d). Finally, the slope of the linear relationship between the average value and logarithmic scale of the time is calculated and used to calculate then the effective thermal conductivity, as shown in Fig. (A1e). Figure A1 depicts the steps of the data processing steps for the test constructed in Kai city, while the same steps are applied for all tests in other sites.

These steps are followed by the data analysis steps, as explained in the previous sections. Figure (B1) in Appendix B depicts these steps for the data recorded in Kai city. The oscillatory part, which is extracted and shown in Fig.(A1d), is fitted with the values calculated from Eq.(7). The *fminsearch* function in Matlab is used to minimize the root mean square errors between the fitted and experimental data by changing the multi variables (Amplitude A , phase shift φ , and cycle time ω_0 in Eq.(7)). *fminsearch* uses the Nelder-Mead simplex algorithm; The algorithm first creates a simplex around the initial guess x_0 by adding 5% of each component of $x_0(i)$ to x_0 . Figures B1a, and b, depict the fitting functions for inlet and outlet temperatures.

Figure (8a, and b) depict λ_{eff} calculated from the NTRT and OscTRT in periods of 12~15 hr, 12~30 hr, and 12~60 hr in NTRT, respectively, while the periods are 12~15 hr, 12~20 hr, and 12~24 hr in OscTRT. The NTRT results show instability and differences between the three periods, with a maximum value of 0.54 W/m.K in Miyoshi. While the results of the OscTRT show more stability and robustness with a maximum difference of 0.04 W/m.K in Sapporo city. The NTRT is vulnerable and is affected strongly by the daily variation of the heat energy on the soil surface, while the OscTRT response shows more robustness. As the OscTRT follows the periodic heating pattern with maximum and minimum values of 20 kW and 8 kW with an average value of 14 kW, it absorbs the daily impact on the surface. Also, the same robustness can be noted in the amplitude ratio values in different periods of the OscTRT as shown in Fig. (8c).

These results concluded that the period of 14 hours of an OscTRT is enough to calculate the λ_{eff} with an accuracy of 98 % in three sites (Sapporo, Niseko, and Miyoshi), 87% in one site (Kai city) and 74% in one site (Tokyo city). Hence the OscTRT has a promising potential to save more than 77 % of the time needed for NTRT.

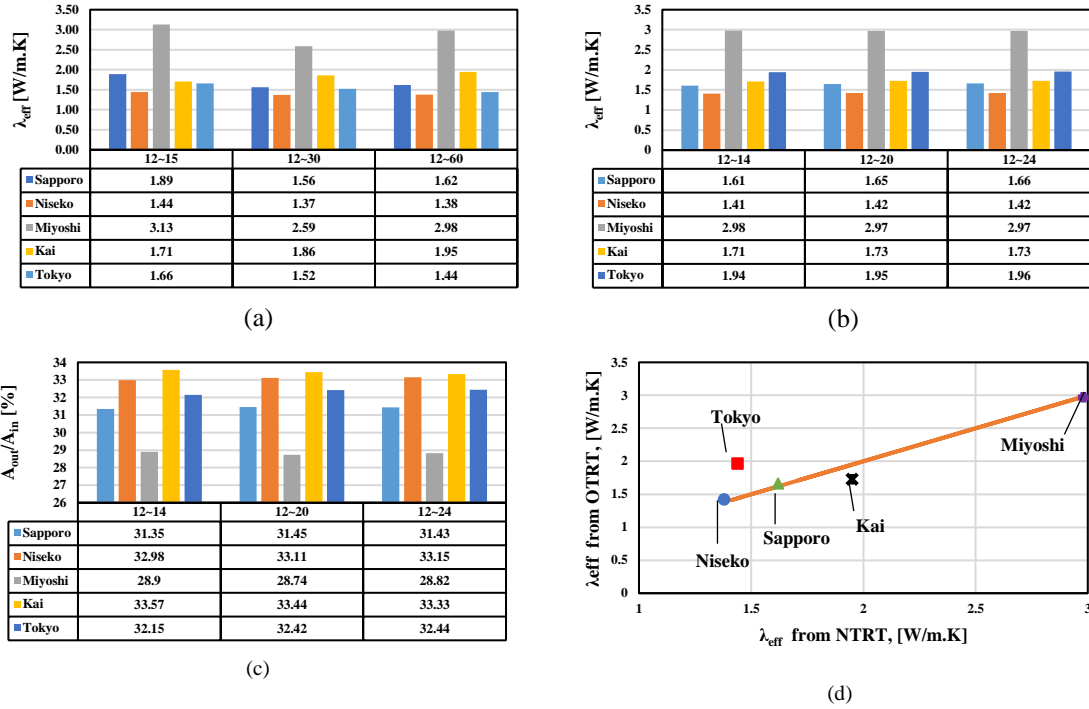

Fig. (8) Summary of the results, a) λ_{eff} from NRTR vs OTRT, b) Amp. Ratio vs λ_{eff}

3.4. Comparison between the NTRT and OscTRT

The comparison between the effective conductivity, which is calculated from the OscTRT and the NTRT, is indicated in Fig.(8d). The root means square error (RMSE) between the two results is 0.25 W/m.K with a square error maximum value of 0.27 w/m.K in Tokyo city. Be noted that the OscTRT is conducted for 24 hours compared to NTRT with more than 60 hours. The error values are -0.04,-0.04,+0.01,+0.22,and -0.52 W/m.K for Sapporo, Niseko, Kai, Miyoshi, and Tokyo cities. The error value includes the measurements error and operating errors. In addition, the error is maximum in Kai and Tokyo city, where we expected that the groundwater affects the underground’s thermal response.

Therefore, it is noteworthy that the relationship between the amplitude ratio of inlet and outlet temperatures and the effective conductivities which are calculated from the NTRT could be a rational alternative to predict the conductivity with the help of numerical simulations and artificial intelligence applications, as shown in Fig. (9). Although The three sites have distinct geological, hydrological, and thermal conditions, a linear relationship can be derived from Fig.(9).

On the other hand, we believe this method needs a comprehensive investigation to explore and clarify the impact of these parameters on the response and amplitude ratio. These goals are the main objectives of future studies using inclusive computational fluid dynamics simulations.

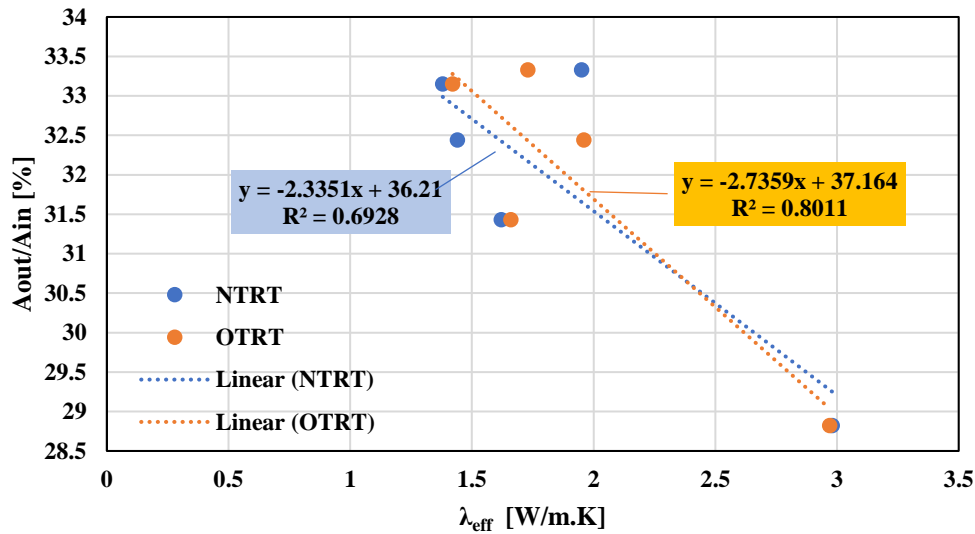

Fig. (9) Relationship between Amp. ratio and calculated λ_{eff} .

4. Conclusions

A new thermal response test method is proposed to shorten test time and save test and labor costs, using an oscillating heating signal in the form of a sine wave with a specific amplitude and frequency. In this study there are many conclusions can be derived as follows:

- 1- A new OTRT is proposed to decrease the TRT time from 60 hours to 14 hours and save test and labor costs by 77 %.
- 2- The effective conductivity, which the new OTRT calculates, has an RMSE of 0.25 W/m.K compared with the NTRT.
- 3- The new TRT machine has been built and tested successfully.
- 4- A new analysis method is developed.
- 5- A new key parameter (Amp. Ratio between Inlet and Outlet temperatures) is proposed for future investigation
- 6- A linear relationship is defined between the effective conductivity and amplitude ratio, which shows a good potential to generalize this method in future work.
- 7- Various geological, hydrological, and thermal conditions are tested.

Although the OscTRT shows promising potential using the experimental measurements in different hydrological, geological, and thermal conditions, this method needs a comprehensive investigation to explore and clarify the impact of these parameters on the response and amplitude ratio. These goals are the main objectives of future studies using inclusive computational fluid dynamics simulations and artificial intelligence.

References

- [1] Reuss M. The use of borehole thermal energy storage (BTES) systems. *Adv. Therm. Energy Storage Syst. Methods Appl.*, vol. i, Woodhead Publishing Limited; 2014, p. 117–47. doi:10.1533/9781782420965.1.117.
- [2] Spitler JD, Bernier M. Vertical borehole ground heat exchanger design methods. J.D. Spitler and M. Bernier; 2016. doi:10.1016/B978-0-08-100311-4.00002-9.
- [3] Sanner B, Hellström G, Spitler J, Gehlin S. Thermal Response Test – Current Status and World-Wide Application. *Proc World Geotherm Congr 2005*:24–9.
- [4] Marcotte D, Pasquier P. On the estimation of thermal resistance in borehole thermal conductivity test. *Renew Energy* 2008;33:2407–15. doi:10.1016/j.renene.2008.01.021.
- [5] Gehlin S. Borehole thermal energy storage. *Adv. Ground-Source Heat Pump Syst.*, Woodhead Publishing Limited; 2016, p. 295–327. doi:10.1016/B978-0-08-100311-4.00011-X.
- [6] Zhang X, Han Z, Ji Q, Zhang H, Li X. Thermal response tests for the identification of soil thermal parameters: A review.

- Renew Energy 2021;173:1123–35. doi:10.1016/j.renene.2020.12.028.
- [7] Zeng HY, Diao NR, Fang ZH. A finite line-source model for boreholes in geothermal heat exchangers. Heat Transf - Asian Res 2002;31:558–67. doi:10.1002/hjtj.10057.
- [8] Diao N, Li Q, Fang Z. Heat transfer in ground heat exchangers with groundwater advection. Int J Therm Sci 2004;43:1203–11. doi:10.1016/j.ijthermalsci.2004.04.009.
- [9] Signorelli S, Bassetti S, Pahud D, Kohl T. Numerical evaluation of thermal response tests. Geothermics 2007;36:141–66. doi:10.1016/j.geothermics.2006.10.006.
- [10] Oberdorfer P. Oscillatory Thermal Response Test (OTRT) - an Advanced Method for shallow geothermal applications, developed with comsol, der Georg-August-University at Gottingen, 2014..

Appendix A

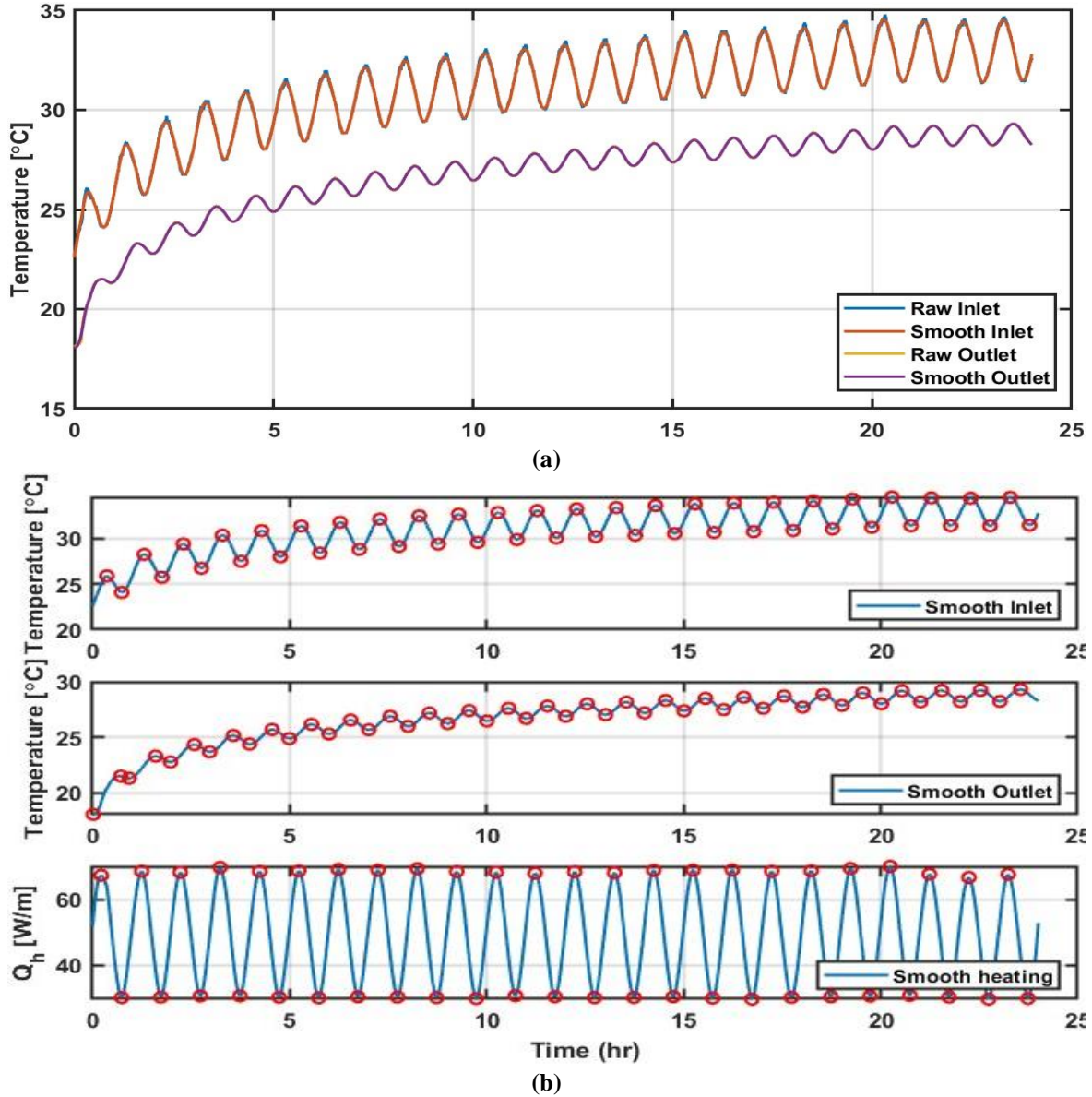

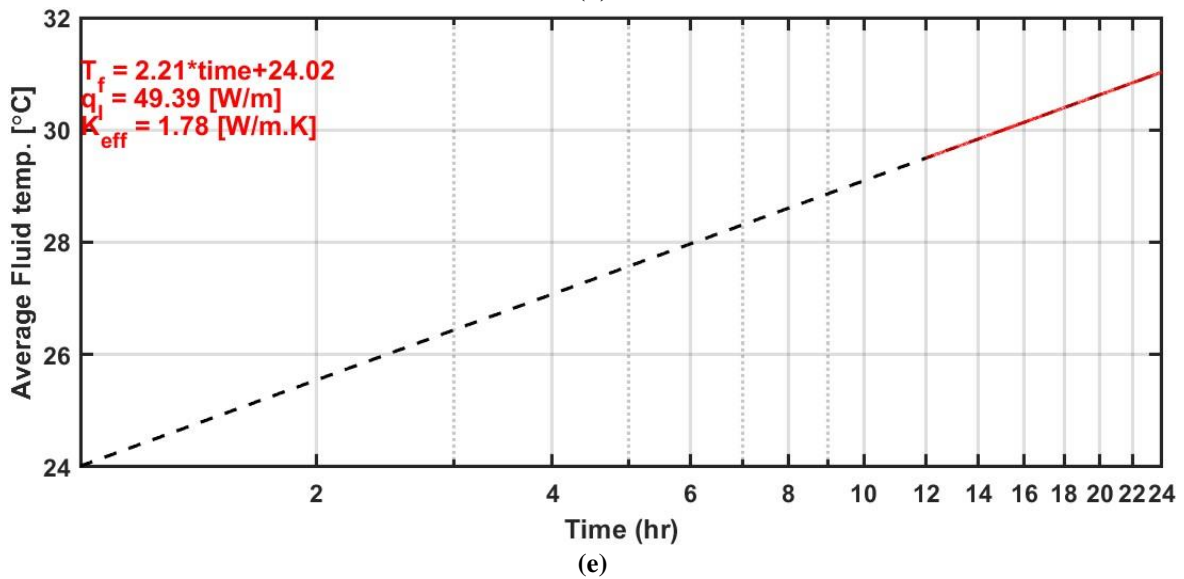
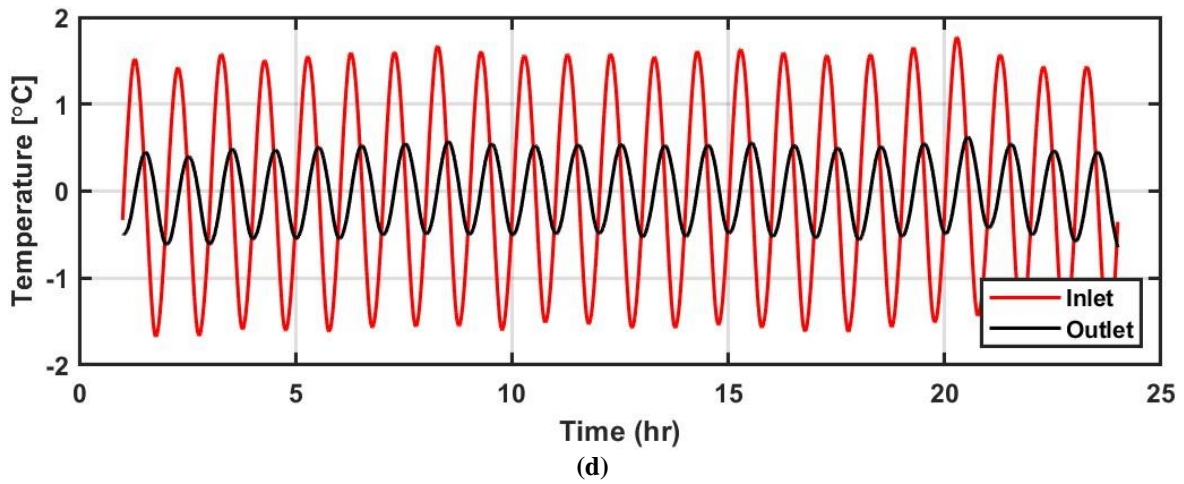
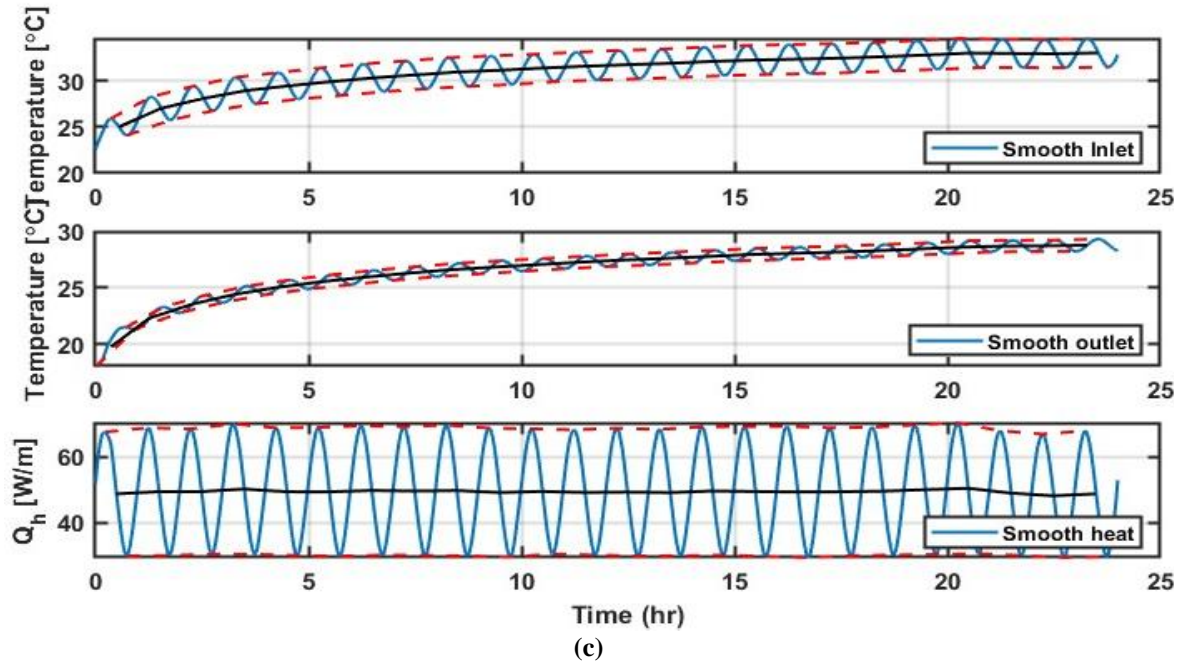

Fig. (A1) Data processing steps using in OscTRT in Kai city

Appendix B

