



14th IEA Heat Pump Conference
15-18 May 2023, Chicago, Illinois

A study on heat and water recovery performance of membrane heat exchanger using different membrane

Van Cong Le^a, Thi Nhan Nguyen^a, Min Sung Lee^b, Jae-il Kwon^c, Dae Hae Kim^d, Sung Joo Hong^e, Min Soo Kim^b, Chan Woo Park^{a,b*}

^a Graduate School of Energy Storage and Conversion Engineering, Jeonbuk National University, Jeonju-si, Jeonrabuk-do 54986, Republic of Korea

^b School of Mechanical Design Engineering, Jeonbuk National University, Jeonju-si, Jeonrabuk-do 54986, Republic of Korea

^c G-TECH Co., Ltd, 43-7 Hyeonseok-Ro, 720 Beon-Gil, Gwangjeok-Myun, Yangju-si, Gyeonggi-do, Republic of Korea

^d Thermalchemical Energy System R&D Group, Korea Institute of Industrial Technology, Cheonan-si, Chungcheongnam-do 31056, Republic of Korea.

^e Department of Mechanical and Automotive Engineering, Jeonju University, Jeonju-si, Jeonrabuk-do 55069, Republic of Korea

Abstract

Industrial energy consumption is extremely high. Thermal power plants contribute to approximately 40% of total water withdrawal in the US but dissipate a large amount of vapor and heat energy. Transport membrane condensers have been demonstrated to have great potential to recovery waste heat and water as a combination of membrane condensers and heat exchangers. In this study, a laboratory membrane heat exchanger system was developed using plate ceramic membrane and hollow fibers. The heat and water recovery performances were studied to estimate the heat and mass transfer characteristics of membrane heat exchangers. The operating conditions show significant effects on the recovery performances of system. A computational fluid dynamics (CFD) model was developed using experimental data to consider the heat and mass transfer. The simulation model shows great agreements with experimental results. The temperature distribution as well as vapor mass fraction were analyzed to have an insight about the condensation and mass transfer of water vapor.

© HPC2023.

Selection and/or peer-review under the responsibility of the organizers of the 14th IEA Heat Pump Conference 2023.

Keywords: Transport membrane condenser (TMC), heat exchanger, heat recovery, water recovery, computational fluid dynamics (CFD)

1. Introduction

Freshwater sources are steadily decreasing over this decade due to the population growth and living standards [1]. The energy industry consumes an enormous amount of fuel resources. Flue gas in the power plant unit consists of water vapor up to 13% volume fraction and take 50 – 80% heat loss from boiler which accounts for 3-8% total energy of the units [2]. Several efforts have been done to reclaim energy and water from the waste gases. By recovery the heat loss and wastewater, not only the boiler efficiency can be greatly improved but the feed consumption can be significantly reduced [3]. Typically, transport membrane condenser (TMC) is a promising method to recovery the wasted sources and enhance the industrial thermal process efficiency. By the mean of using a proper membrane, the recovery efficiencies of TMC are particularly improved. It has been demonstrated that the TMC can supply 30% of feed water in boiler unit under a proper working condition. In this work, transport membrane condensers with two types of membranes were studied experimentally and numerically.

2. Methodology

The experimental scheme of a hollow fiber transport membrane condenser is shown in figure 1. The dense alumina hollow fibers were assembled in an acrylic round tube. A water boiler was used to generate vapor and control the gas temperature. The air compressor was incorporated with the mass flow control (MFC) to control humid gas circulating though membrane condensers. The cooling water was controlled by a pump and cooling

bath to flow inside the hollow fiber. Thermocouples and humidity sensor were installed to measure the operating conditions. The mass of water transport to water side was measured by a water level sensor.

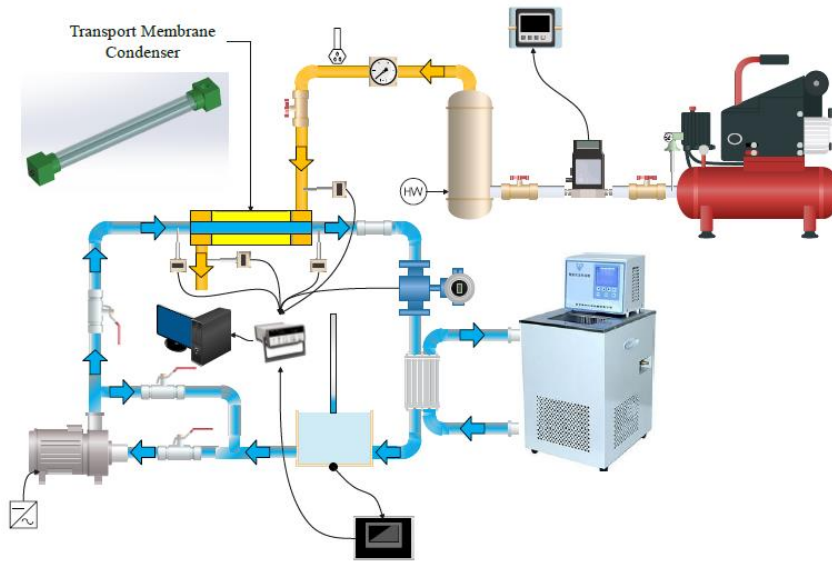

Fig. 1. Experimental scheme of circular type transport membrane condenser

Similarly, a plate membrane was applied in the experiment system for comparison. The humid air and cold water were supplied onto two side of membrane. The velocity and temperature of inlet gas and water were modified to evaluate the recovery behavior. The water and heat recovery can be obtained as following:

$$J = \frac{\Delta m}{\Delta t A} \quad (1)$$

$$Q = \frac{C_p m_l \Delta T + m_T E_w}{A} \quad (2)$$

3. Numerical study

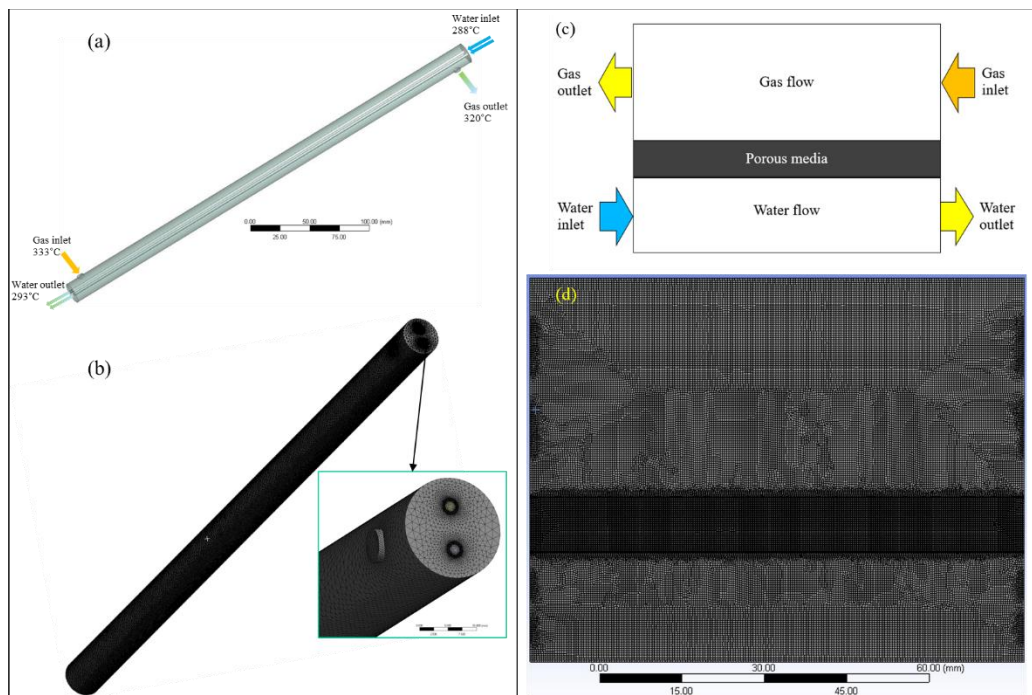

Fig. 2. (a) Schematic and (b) meshing of hollow fiber heat exchanger (c) Schematic and (d) meshing of flat membrane heat exchanger

A CFD code in ANSYS Fluent was used to conduct a simple 2D model of plate membrane condenser, as presented in figure 2c and 2d. The numerical model of a hollow fiber membrane condenser was then developed in 3D configuration. The simulation model consists of three computation zones which are gas, water flow and membrane. The model geometry and parameters were built based on the experiment setup. The simulation conditions are presented in Table 1. The species transport in Volume of Fluid (VOF) multiphase model was utilized with gas mixture as the primary phase and water liquid in the secondary phase. The condensation of water vapor was solved using the evaporation-condensation Lee's model. The condensation rate of vapor was considered as the mass transfer between water liquid and vapor phases. The mass transfer is solved by the following equation:

$$\frac{\partial}{\partial t} (\alpha_v \rho_v) + \nabla \cdot (\alpha_v \rho_v \vec{v}_v) = \dot{m}_{lv} - \dot{m}_{vl} \quad (3)$$

For the mass transport through the membrane, the permeation of fluid through the ceramic membrane was considered as a laminar flow and solved by the porous media model. A momentum sink comprised of viscosity loss and inertial loss was added as following:

$$S_i = - \left(\sum_{j=1}^3 D_{ij} \mu v_j + \sum_{j=1}^3 C_{ij} \frac{1}{2} \rho |v| v_j \right) \quad (4)$$

Table 1. Boundary conditions

Parameter	Value
Water temperature (K)	288
Gas temperature (K)	334
Porosity (%)	35
Water flow rate (LPM)	0.1
Gas flow rate (LPM)	4 to 20
Vapor content (-)	0.13

4. Results and discussions

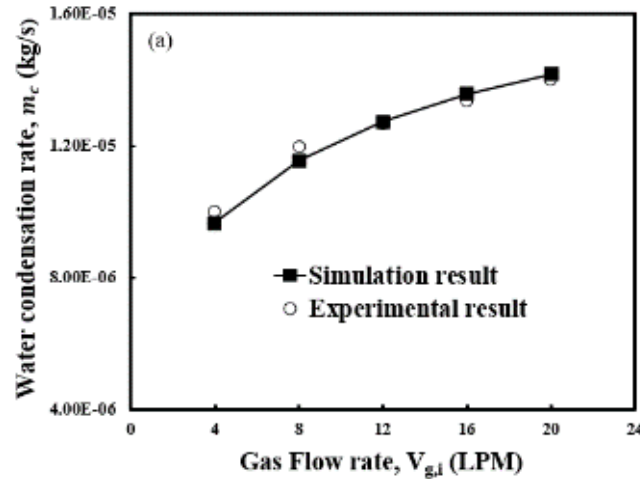

Fig. 3. Comparison of experimental and simulation results at different operating conditions

Fig. 3 shows the comparison between experimental and simulation results with different operating conditions. The simulation results were found to have a great agreement with experimental data. The temperature distribution and vapor mass fraction were studied at different conditions. The temperature and vapor mass fraction of hollow fiber condenser model are presented in Fig. 4 and Fig. 5, respectively. It can be observed that the gas flow temperature decreases along with the flow direction. The decline in gas temperature demonstrated the heat retrieval in the gas stream. On the other hand, the vapor distribution shows a reduction of mass fraction in company with the gas direction. The vapor mass fraction was obtained approximately 0.53 in the gas outlet. Obviously, the moisture content was recaptured into the water side.

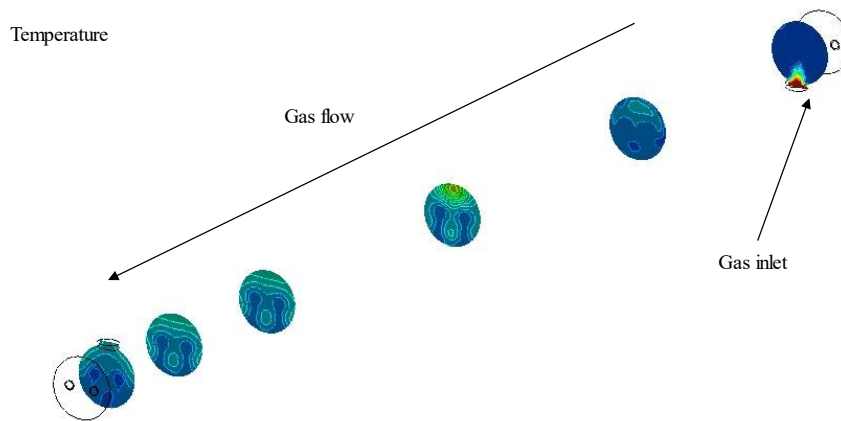

Fig. 4. Temperature of hollow fiber condenser

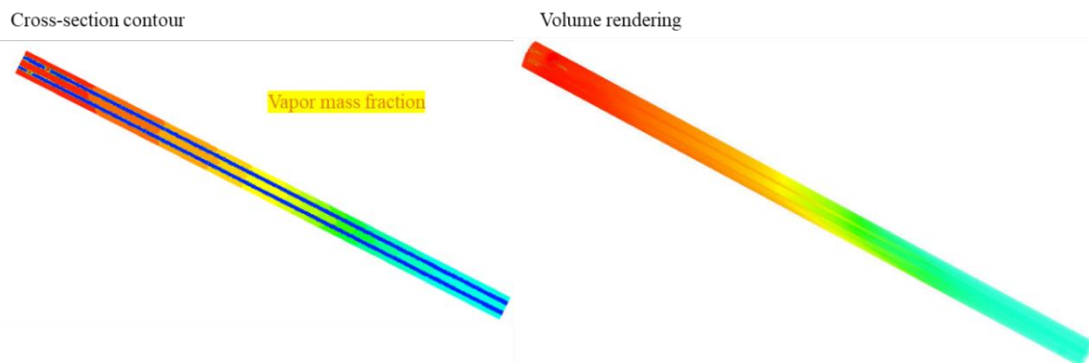

Fig. 5. Vapor mass fraction of hollow fiber condenser

5. Conclusion

In this work, a membrane heat exchanger is proposed for application of heat and wastewater recovery from flue gas using ceramic hollow fiber membranes. A 3D CFD model was developed based on experimental data. A great agreement was found between numerical and experimental results. The simulation results such as temperature contour and mass fraction of vapor in the gas phases have given an insight into the mechanism of the membrane condenser.

Acknowledgements

The authors would like to appreciate the research funds for their support with this project. This research was supported by the Basic Science Research Program through the NRF (National Research Foundation of Korea, grant No. RS-2023-00209123). The authors also appreciate the KETEP (Korea Institute of Energy Technology Evaluation and Planning, grant No. 20192010107020) and the Technology Development Program funded by the MSS (Ministry of SMEs and Startups, grant No. S3276045) for their assistance. And this work was also supported by the Technology Innovation Program (20014699, 20018237, KOITA-RND2-2022-8) funded by the ministry of Trade, Industry & Energy (MOTIE, Republic of Korea).

References

- [1] Salman Memon, Young-Deuk Kim, Sadam Soomro, Mujeeb Iqbal Soomro, Woo-Seung Kim. *A new approach for freshwater production and energy recovery from an oil field*, Journal of Water Process Engineering, Volume 34, 2020, 101145, ISSN 2214-7144. <https://doi.org/10.1016/j.jwpe.2020.101145>
- [2] Chen, H., Zhou, Y., Su, X., Cao, S., Liu, Y., Gao, D., An, L., 2018. *Experimental study of water recovery from flue gas using hollow micro-nano porous ceramic composite membranes*. Journal of Industrial and Engineering Chemistry 57, 349–355. <https://doi:10.1016/j.jiec.2017.08.042>
- [3] Wang, Dexin, Ciora, Richard, Lin, Chengxian, and Ma, Zhanhua. *Flue Gas Water Vapor Latent Heat Recovery for Pressurized Oxy-Combustion*. United States: N. p., 2018. Web. doi:10.2172/1484251.