



14th IEA Heat Pump Conference

# Performance evaluation of multi-functional cascade heat pump system for a residential building

**Beom-Jun Kim**, Hye-Jin Cho, Soo-Jin Lee, Taek-Don Kwon, Jae-Weon Jeong\*



- 1. Introduction**
- 2. System overview**
- 3. Sizing process**
- 4. Energy simulation**
- 5. Simulation result**
- 6. Conclusion**

## Heat pump system

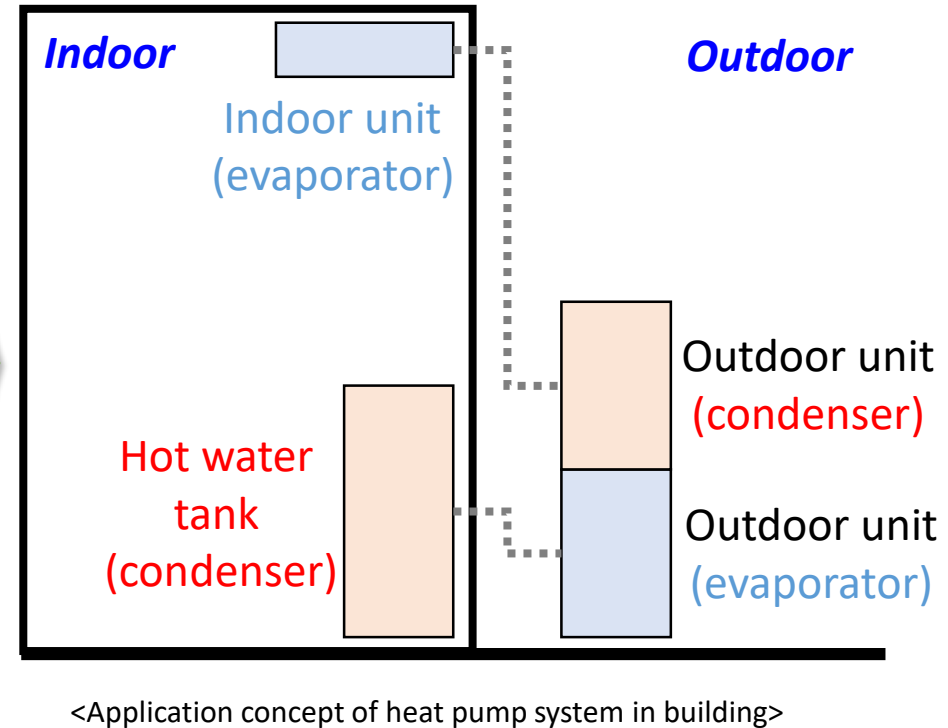
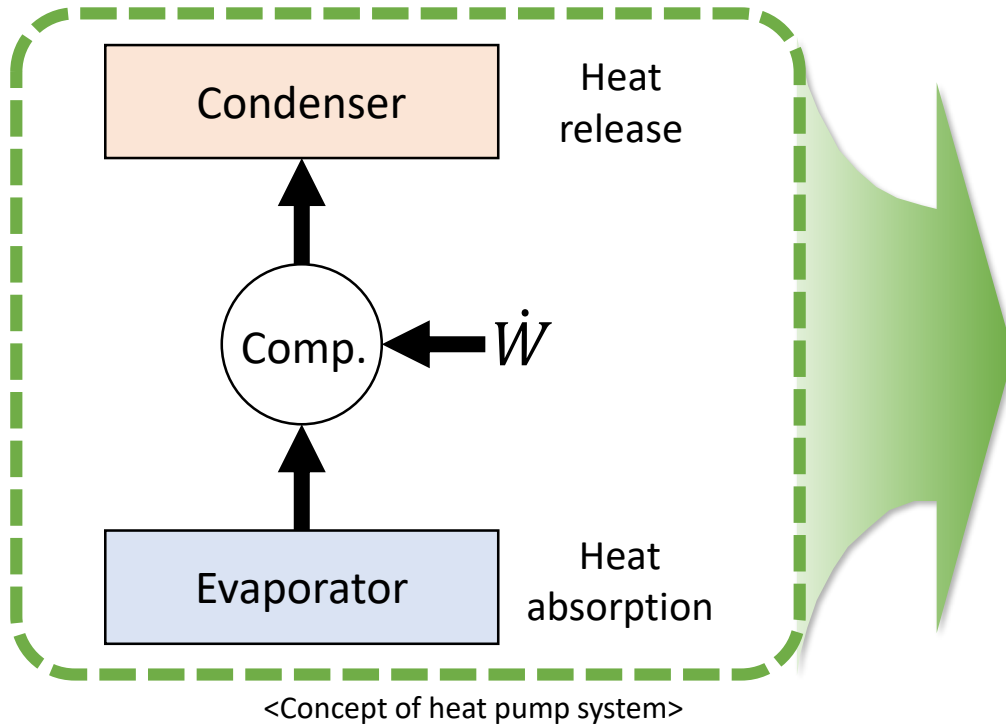

- Cooling the room by absorbing heat in the building through refrigerant evaporation.
- Heating domestic hot water by releasing heat to water inside the tank through the heat dissipation.

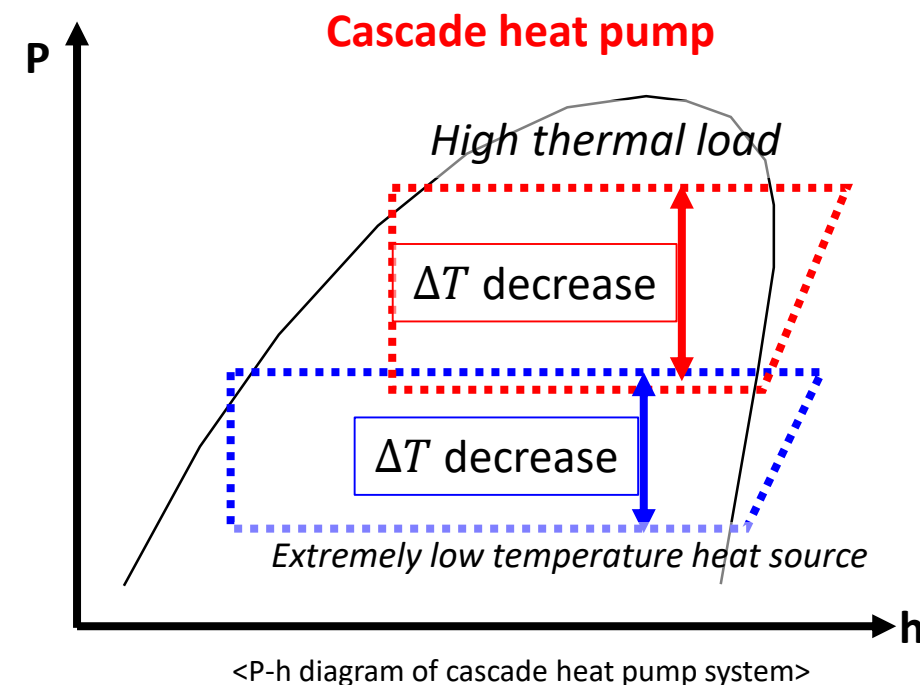
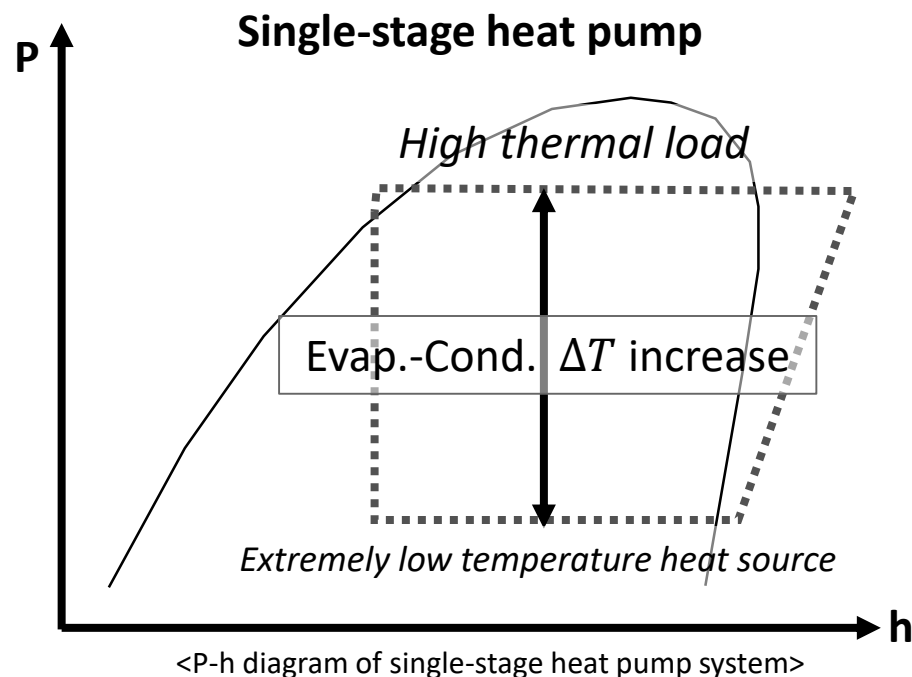

## Cascade heat pump system

- The Energy consumption of the compressor increases.
  - ✓ Temperature difference increases between evap.-cond.
  - ✓ System efficiency decreases.
- A system capable of reducing the load of each cycle compressor by raising the temperature in multiple stages from a low-temperature heat source to a high-temperature load.

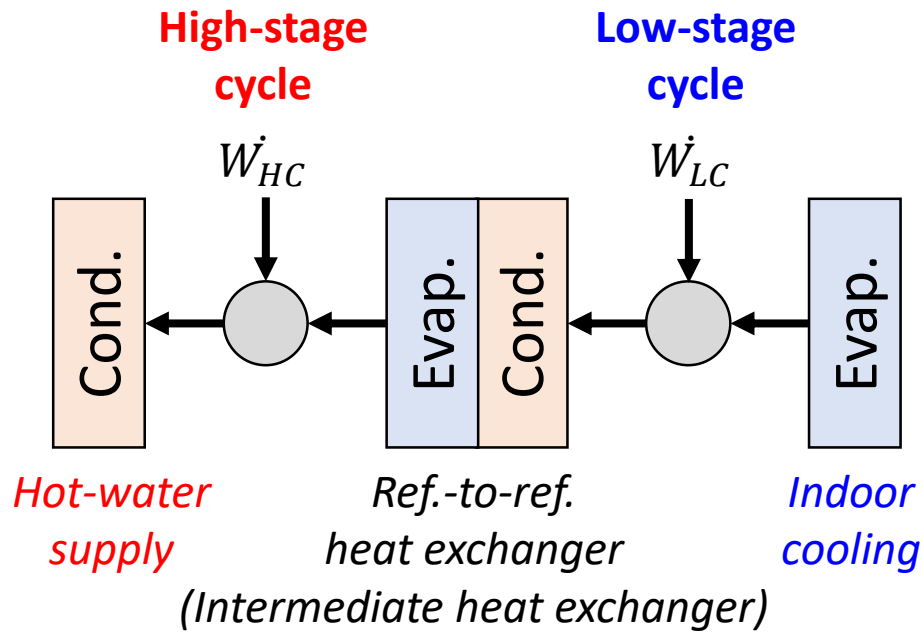

<Concept of cascade heat pump system in residential building>

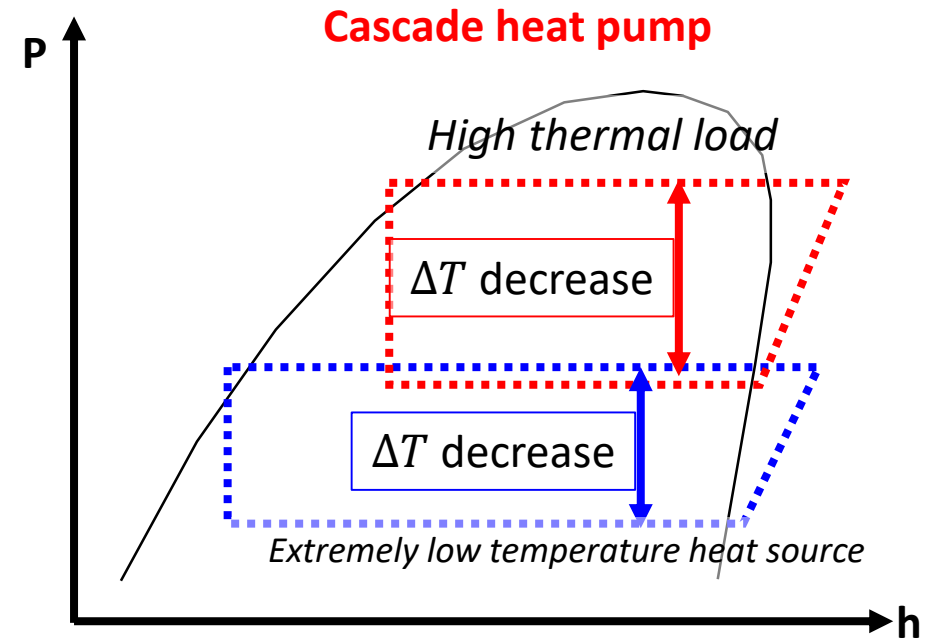

<P-h diagram of cascade heat pump system>

- The calculation of system capacity based on building thermal load and energy simulation studies are insufficient.
- **This study was conducted on system capacity calculation and energy saving analysis when applying a cascade heat pump system in a residential building.**

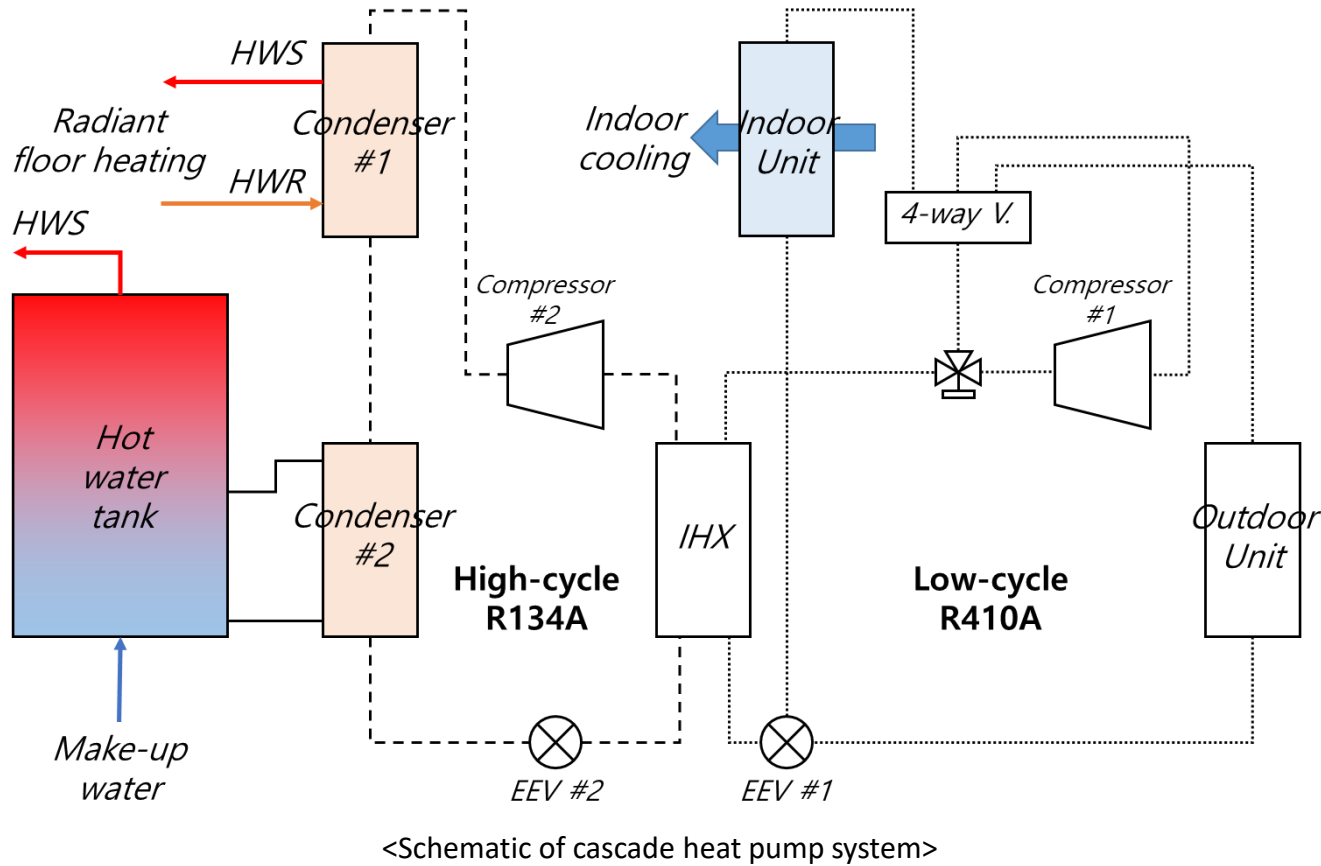

- Low-cycle heat pump (LC) and high-cycle heat pump (HC) are connected to the intermediate heat exchanger.
- LC is responsible for cooling in summer. HC is responsible for water heating for domestic hot water and floor heating.

Heat source	$\Delta T$ (With heat source)	$\Delta T$ (IHX)	$\epsilon_{hx}$	$T_{supply\ air}$	$T_{HWS}$
Air	10	5	0.8	15	60

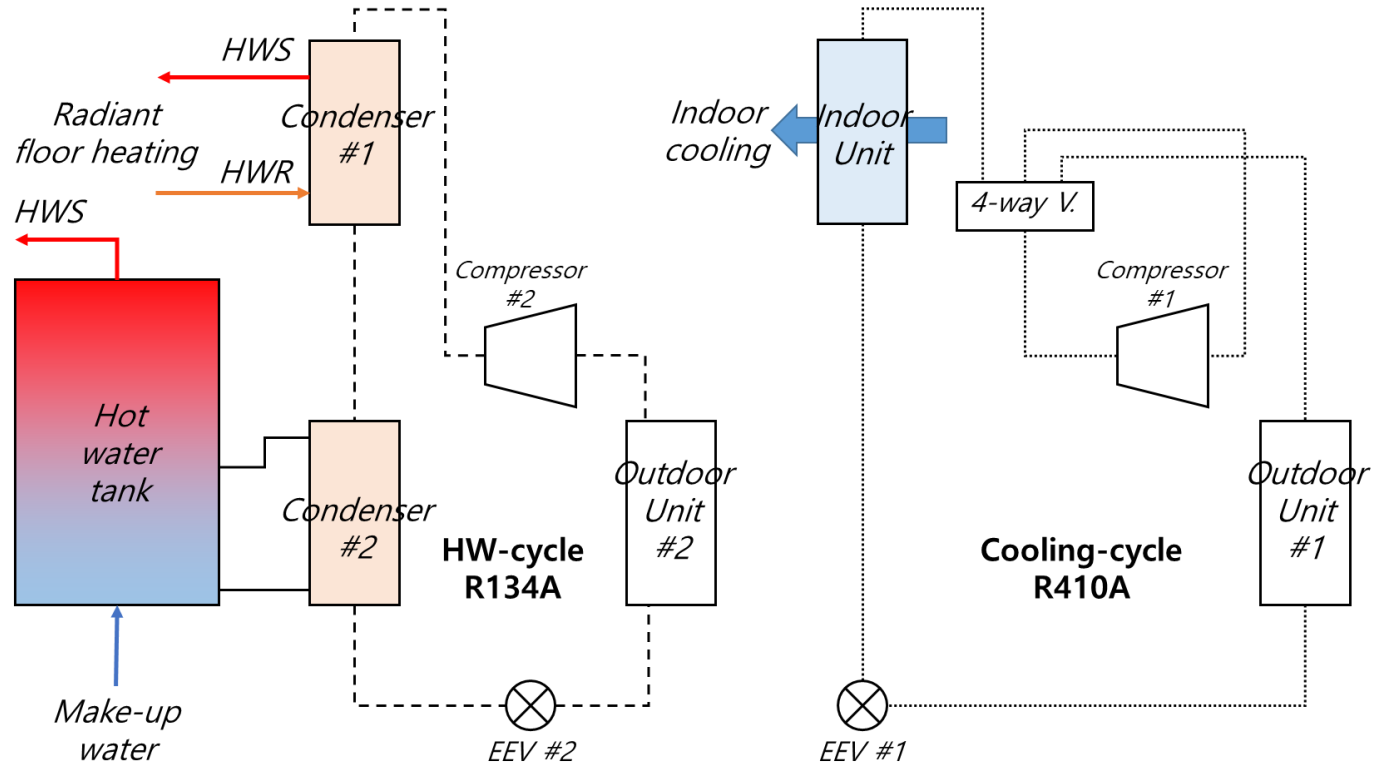

<Schematic of reference heat pump system>

- Each heat pump is a single-stage cycle.
- Cooling-cycle is responsible for cooling in summer.
- Hot water cycle (HW-cycle) is responsible for hot water supply.

Heat source	$\Delta T$ (With heat source)	$\Delta T$ (IHx)	$\epsilon_{hx}$	$T_{supply\ air}$	$T_{HWS}$
Air	10	5	0.8	15	60

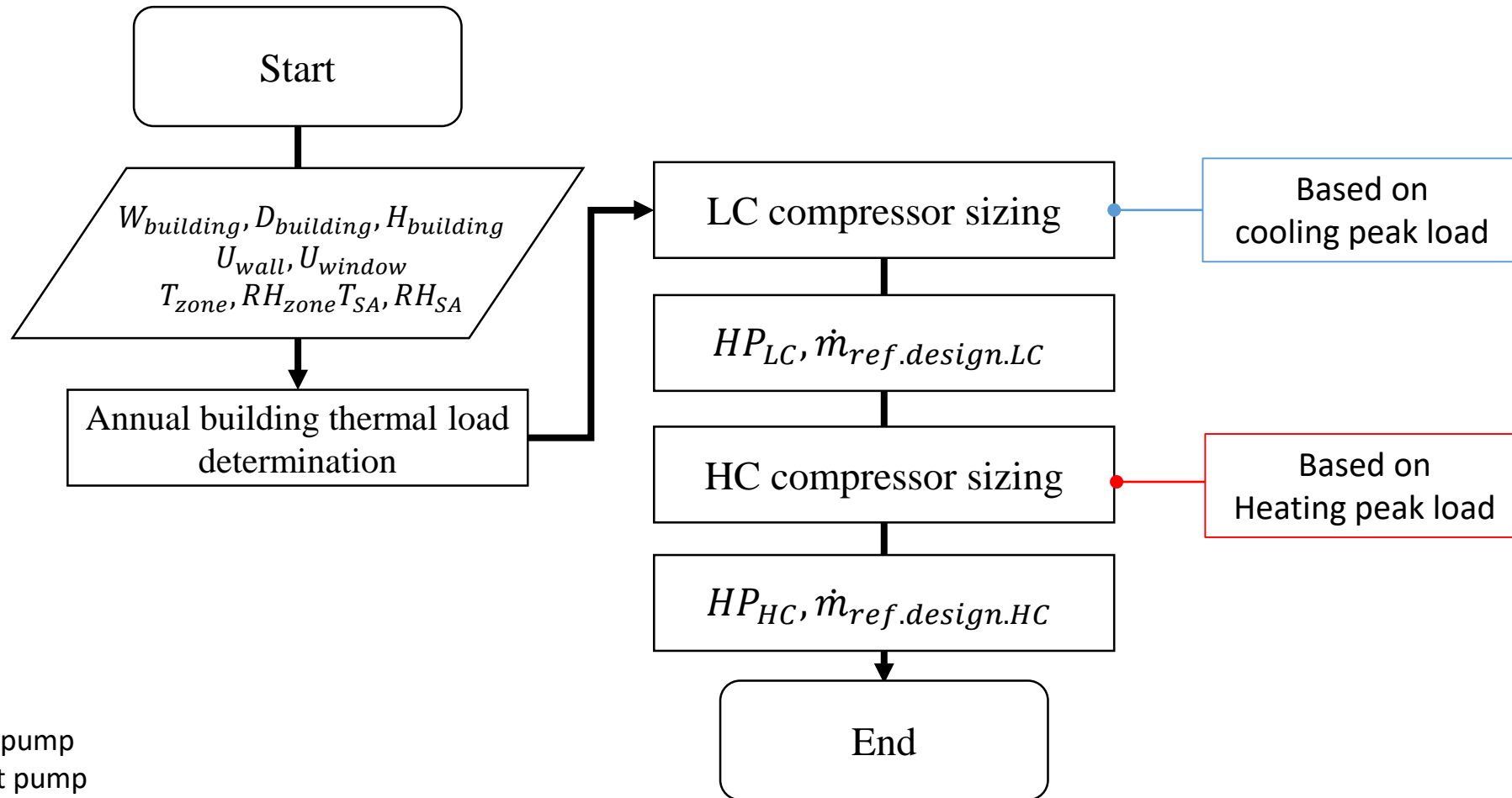

- HP: Horse power
- LC: Low-cycle heat pump
- HC: High-cycle heat pump

Residential, 100 m<sup>2</sup>

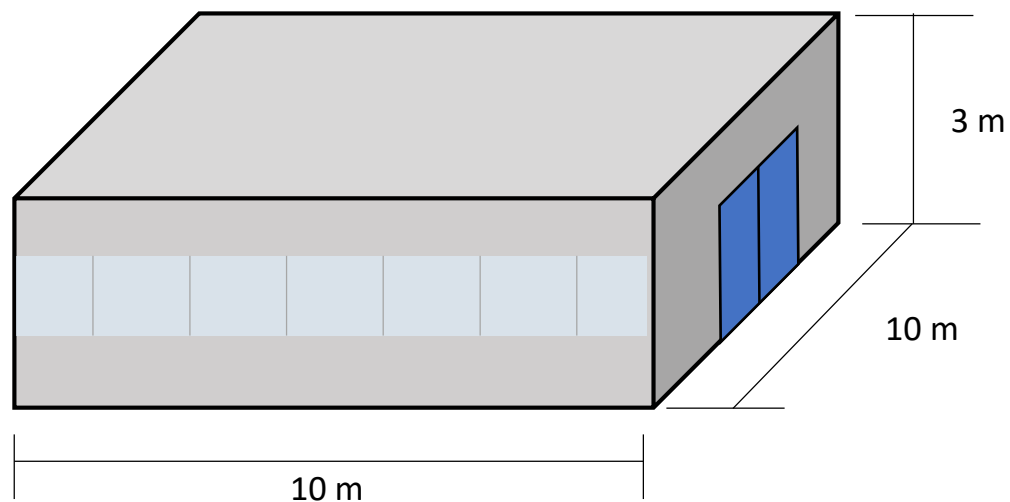

<Schematic of the building model>

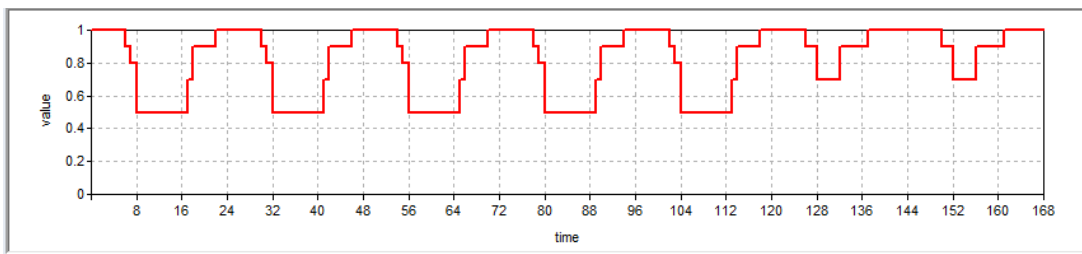

<Schedule for occupants in dwellings>

<b>Weather</b>	EnergyPlus Seoul weather data			
<b>Room set point</b>	Cooling 26°C 50%		Heating 20°C 50%	
<b>Heat gain</b>	Person 130 W/person	Equipment 7 W/m <sup>2</sup>	Light 0.4 W/m <sup>2</sup>	
<b>U-value</b>	Outdoor wall 0.17 W/m <sup>2</sup> K	Roof 0.15 W/m <sup>2</sup> K	Floor 0.17 W/m <sup>2</sup> K	Window 1.12 W/m <sup>2</sup> K
<b>Infiltration rate</b>	0.6 1/h			
<b>Refrigerant</b>	Cooling R410A		Zone and water heating R134A	

<Input data for building thermal load calculation>

Based on ASHRAE Standard 55

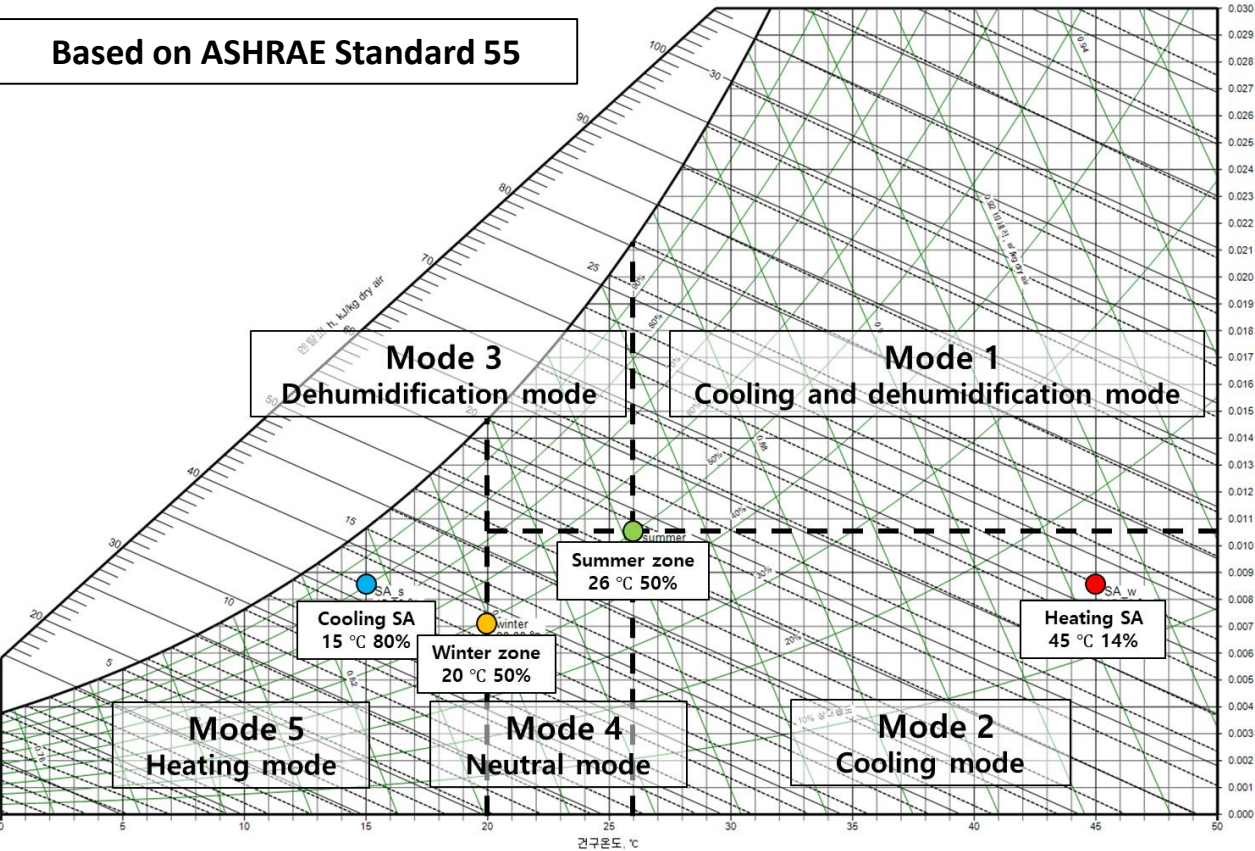

Set point		Operation mode	SA condition
Temperature [°C]	Humidity ratio [g/kg]		
Above 26 °C	Above 10.5 g/kg	<b>Mode 1</b> Cooling and dehumidification mode	15 °C / RH 80%
	Under 10.5 g/kg	<b>Mode 2</b> Cooling mode	15 °C / RH 80%
20 °C ~ 26 °C	Above 10.5 g/kg	<b>Mode 3</b> Dehumidification mode	15 °C / RH 80%
	Under 10.5 g/kg	<b>Mode 4</b> Neutral mode	20 °C / RH 50%
Under 20 °C	-	<b>Mode 5</b> Heating mode	45 °C / RH 15%

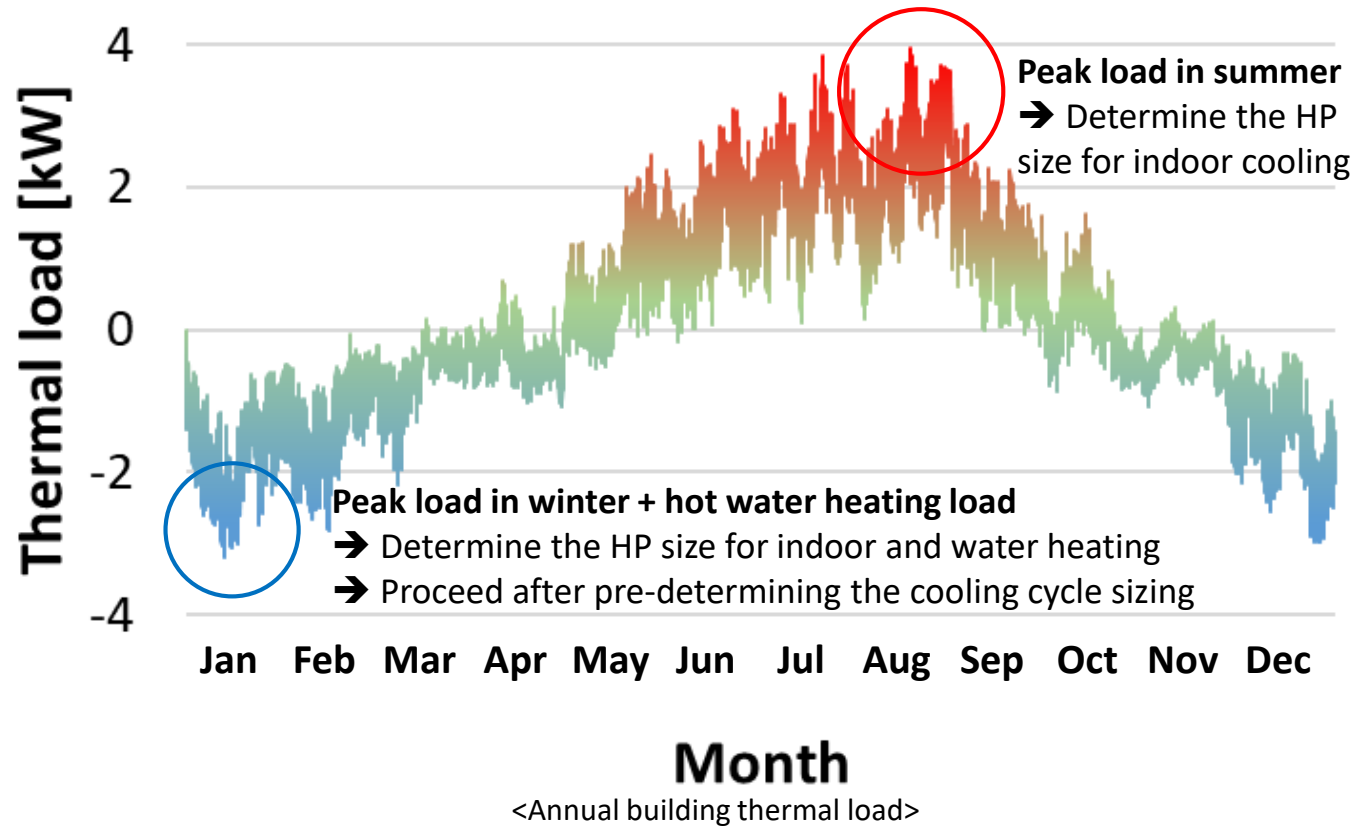

Peak data	$T_{oa}$ [°C]	$RH_{oa}$ [-]	$T_{zone}$ [°C]	$RH_{zone}$ [-]	$\dot{Q}_{sen}$ [kW]	$\dot{Q}_{lat}$ [kW]	$\dot{V}_{hw}$ [L]
Cooling	31.3	0.53	39.22	0.36	2.71	0.86	20
Heating and water heating	-13.6	0.83	12.24	0.30	-2.52	-0.65	26

< Data in case of peak load >



# Energy simulation

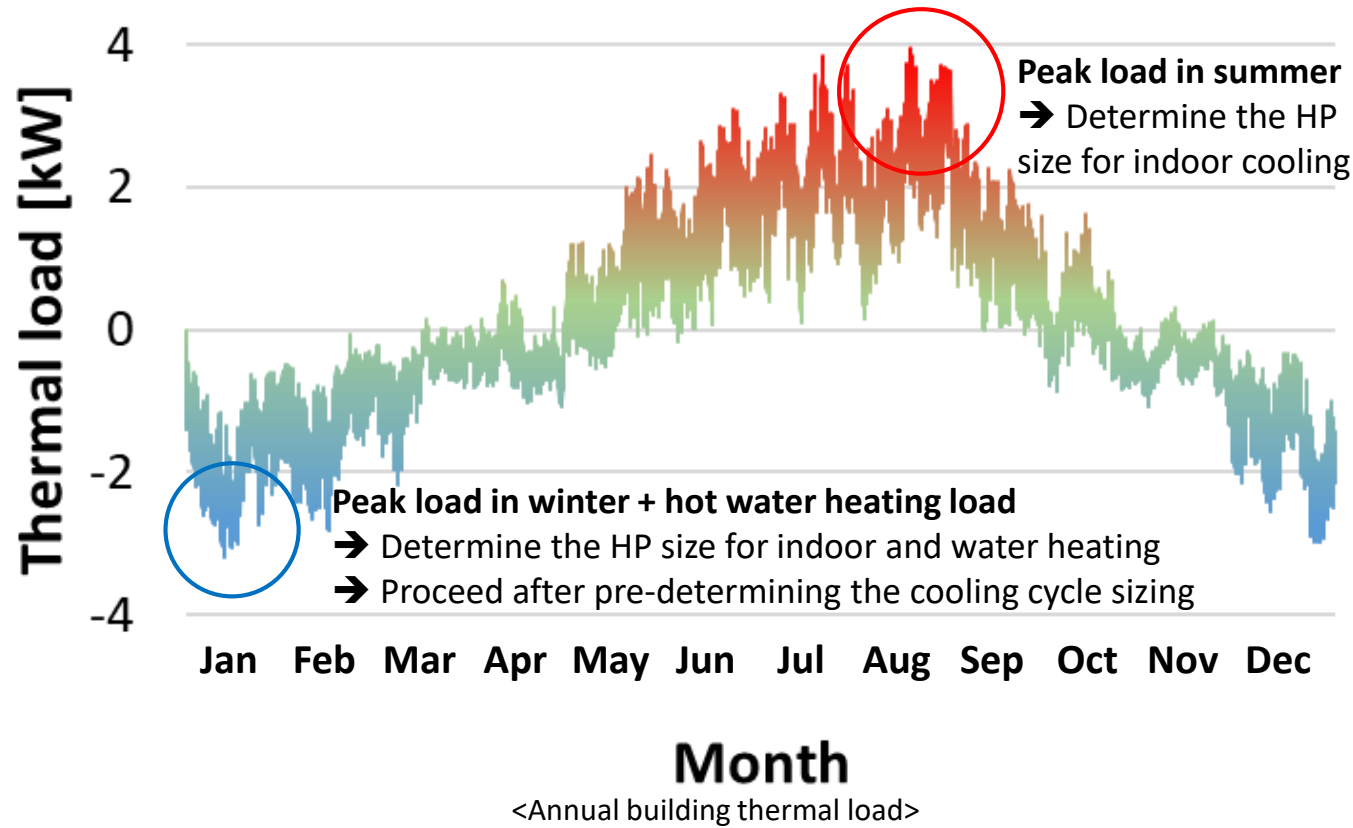

<b>Cascade system</b>	<b>Low-stage cycle [HP]</b>	<b>High-stage cycle [HP]</b>
	1.1	0.6
<b>Reference system</b>	<b>Cooling cycle [HP]</b>	<b>water heating cycle [HP]</b>
	1.1	1.8

< System size of each cycle >



# Simulation result



#n : LC, HC

Parameter	Indoor cooling and water heating	Indoor and water heating
Heat rate	$\dot{Q}_{evap}$	$\dot{m}_{ref.\#n}(h_{evap.o.\#n} - h_{evap.i.\#n})$
	$\dot{W}_{comp}$	$\dot{m}_{ref.\#n}(h_{comp.o.\#n} - h_{comp.i.\#n})$
	$\dot{Q}_{cond}$	$\dot{m}_{ref.\#n}(h_{cond.i.\#n} - h_{cond.o.\#n})$
COP	$COP_{cooling} = \frac{\dot{Q}_{evap.LC} + \dot{Q}_{cond.HC}}{\dot{W}_{comp.LC} + \dot{W}_{comp.HC}}$	$COP_{hotwater} = \frac{\dot{Q}_{cond.HC}}{\dot{W}_{comp.LC} + \dot{W}_{comp.HC}}$
Waste heat recovery (in summer)	The amount of waste heat recovered from the condenser of HP (LC) for cooling	
Energy consumption	Compressor, IDU Fan, ODU Fan, Pump	

## Summer

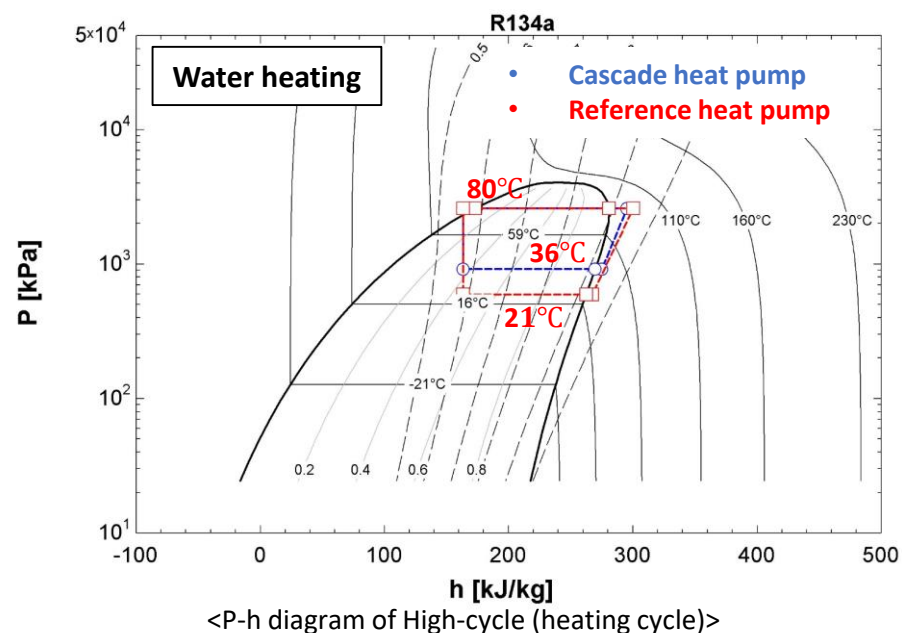
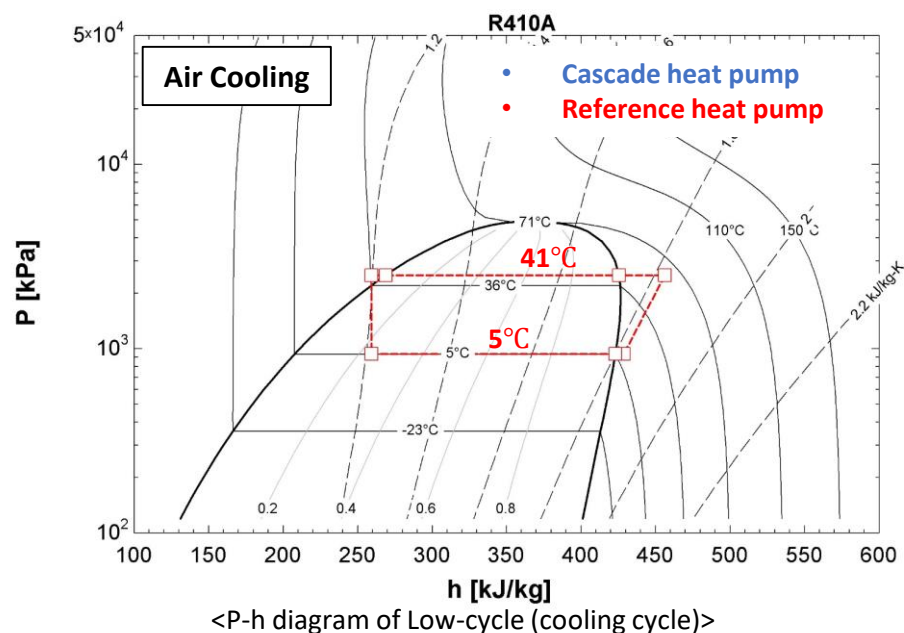

	System	$\dot{m}_{ref}$	$\dot{Q}_{evap}$	$\dot{W}_{comp}$	$\dot{Q}_{cond}$	$\Delta h_{evap}$	$\Delta h_{comp}$	$\Delta h_{cond}$
Low-stage cycle (Cooling)	Cascade	0.03018	5.11 (target)	0.83	5.94	169.4	27.5	196.9
	Reference	0.03018	5.11 (target)	0.83	5.94	169.4	27.5	196.9
High-stage cycle (water heating)	Cascade	0.00364	0.41	0.07	0.48 (target)	111.9	20.0	131.9
	Reference	0.00350	0.36	0.12	0.48 (target)	104.1	32.9	137.0

Winter

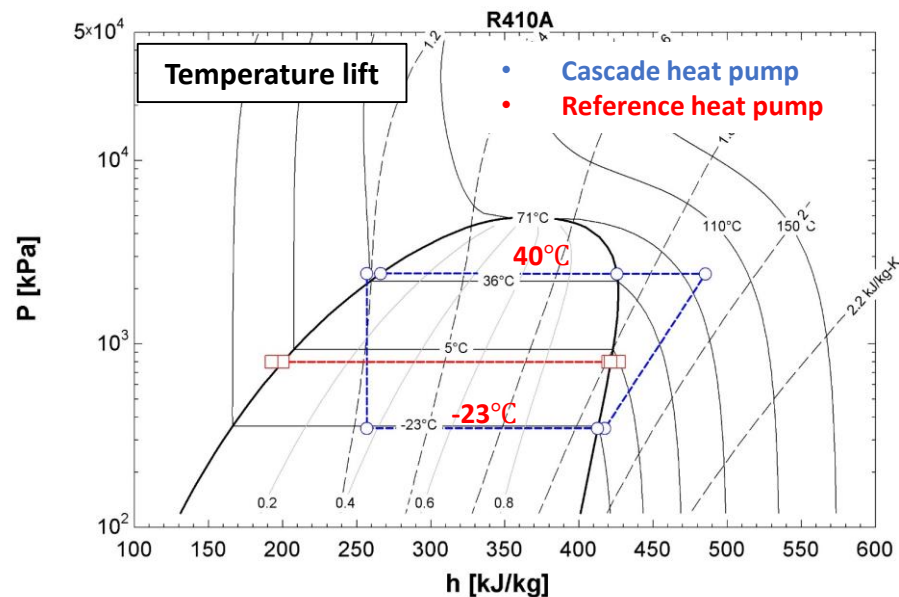

<P-h diagram of Low-cycle (cooling cycle)>

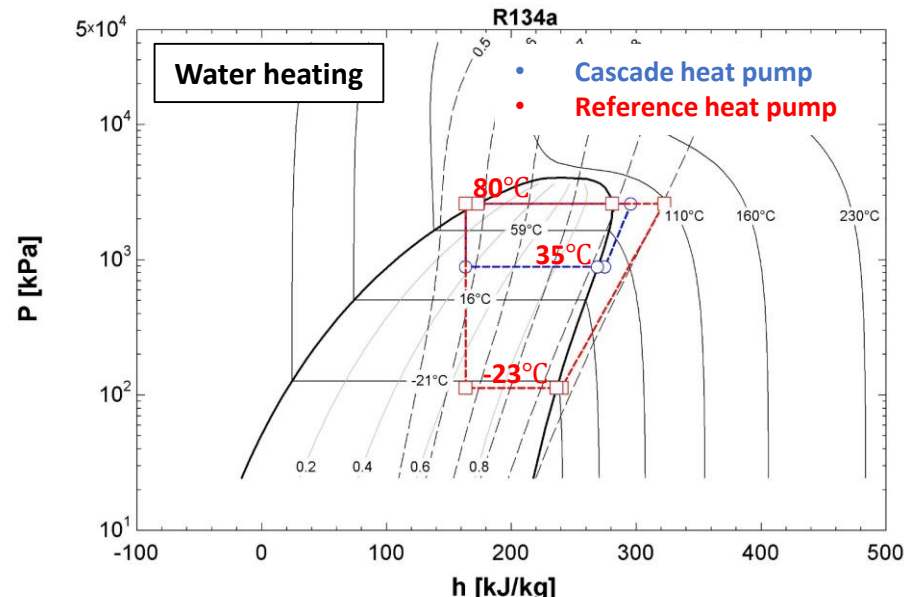

<P-h diagram of High-cycle (heating cycle)>

	System	$\dot{m}_{ref}$	$\dot{Q}_{evap}$	$\dot{W}_{comp}$	$\dot{Q}_{cond}$	$\Delta h_{evap}$	$\Delta h_{comp}$	$\Delta h_{cond}$
Low-stage cycle (Cooling)	Cascade	0.01233	1.97	0.84	2.81	160.4	67.9	228.3
	Reference	0	0	0	0	0	0	0
High-stage cycle (water heating)	Cascade	0.02427	2.70	0.51	3.21 (target)	111.3	21.0	132.3
	Reference	0.02018	1.55	1.66	3.21 (target)	77.0	82.2	159.2



# Simulation result



	Cascade system	Inequality sign	Reference system
$\dot{m}_{ref}$	High	$>$	Low
$\Delta h_{evap}$	High	$>$	Low
$\Delta h_{comp}$	Low	$<$	High
$\Delta h_{cond}$	Low	$<$	High
$\dot{Q}_{evap}$ (in high-cycle)	High	$>$	Low
$\dot{W}_{comp}$	Low	$<$	High



# Simulation result



## ❖ Indoor air cooling and water heating mode

CHP: cascade heat pump  
RHP: Reference heat pump

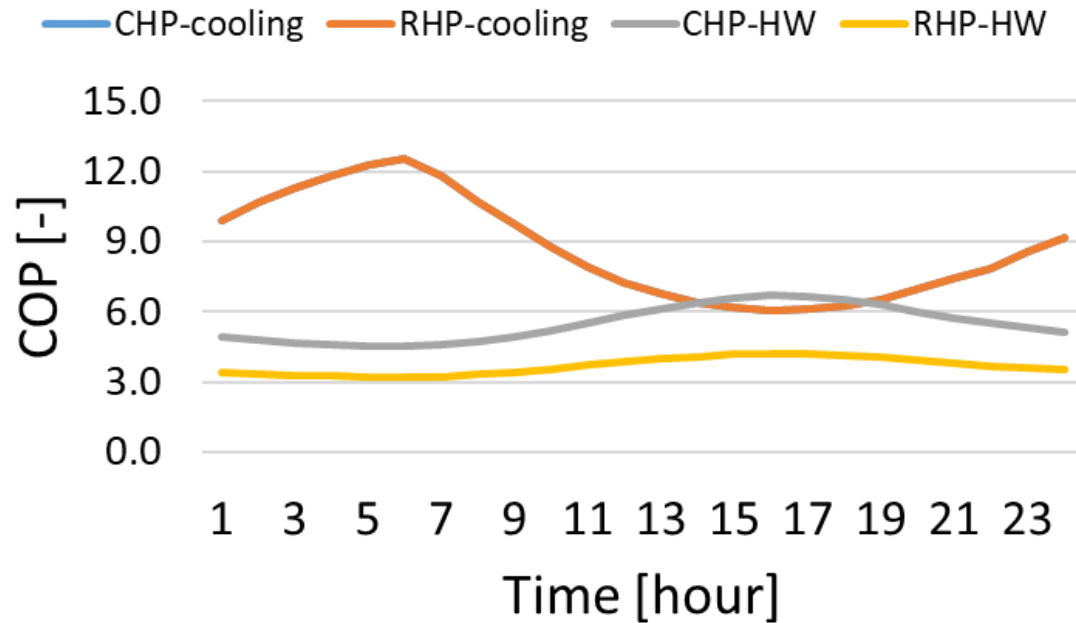

<Coefficient of performance for each cycle>

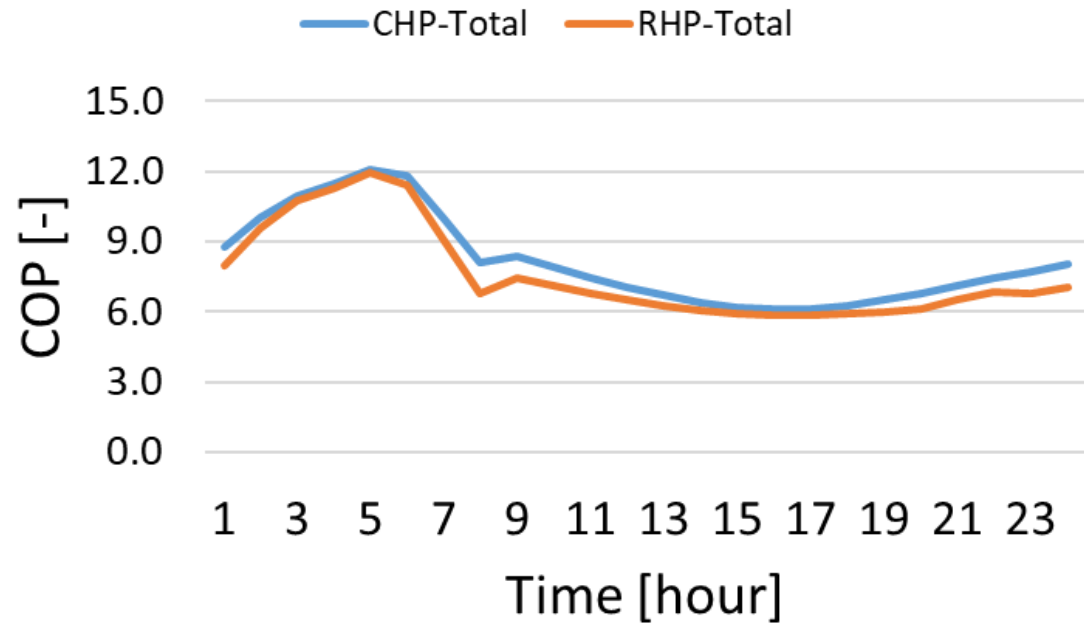

<Total coefficient of performance>

- In the **cooling cycle**, CHP and RHP operate as same, so the **COP graphs is overlapped**.
- **Hot water cycle** showed **higher COP of Cascade heat pump**.

## ❖ Water heating mode

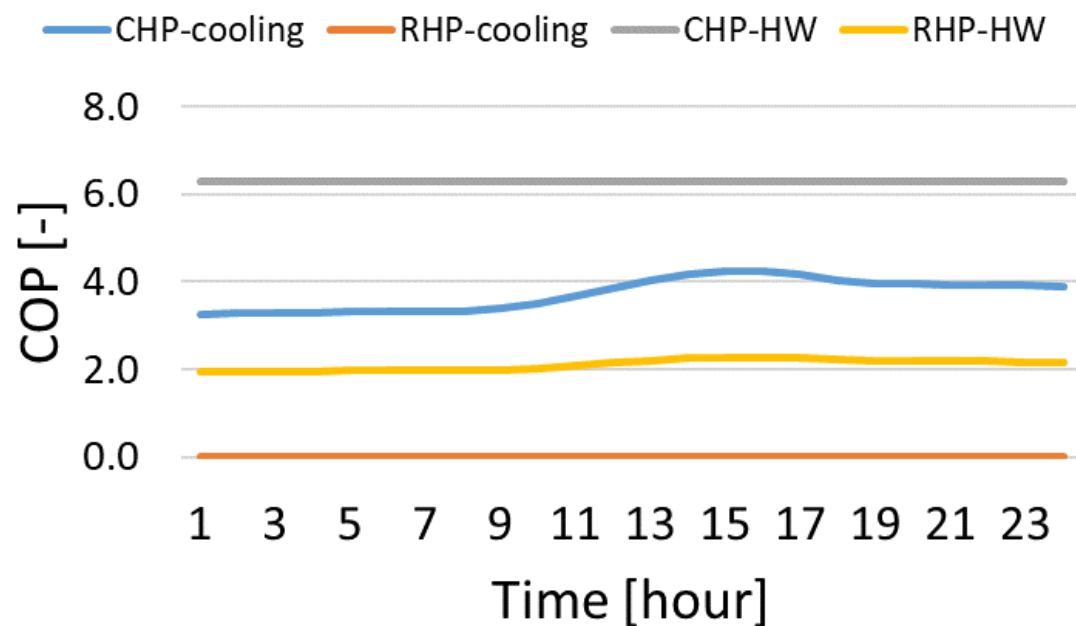

<Coefficient of performance for each cycle>

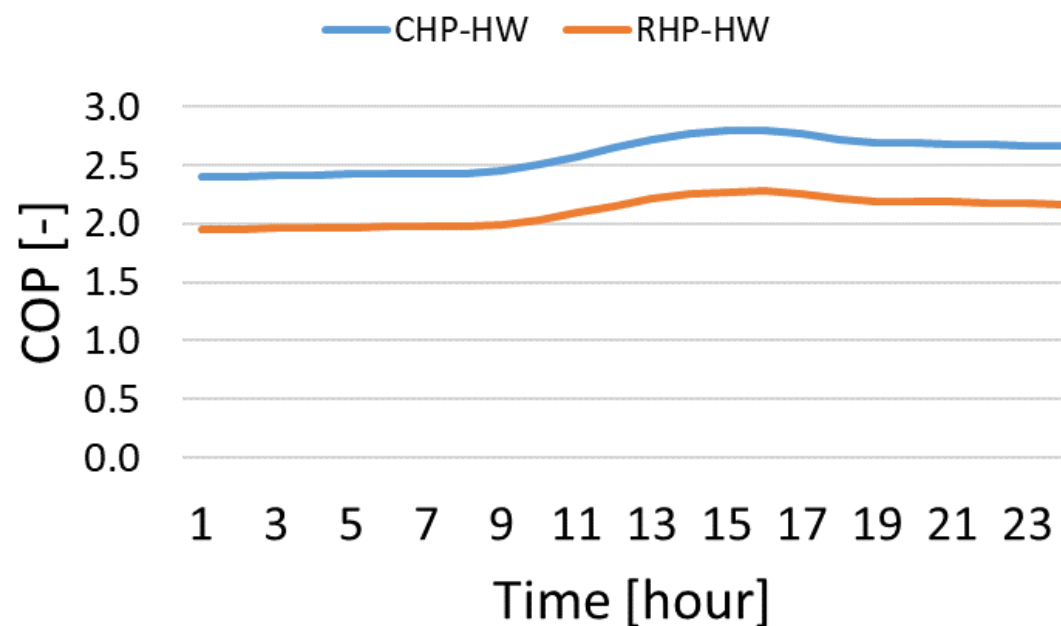

<Total coefficient of performance>

CHP: cascade heat pump  
RHP: Reference heat pump

- The **cooling cycle of the RHP does not operate** in winter, so the COP is zero.
- When operating in heating and hot water mode, the **COP of CHP compared to RHP was relatively higher**.



# Simulation result

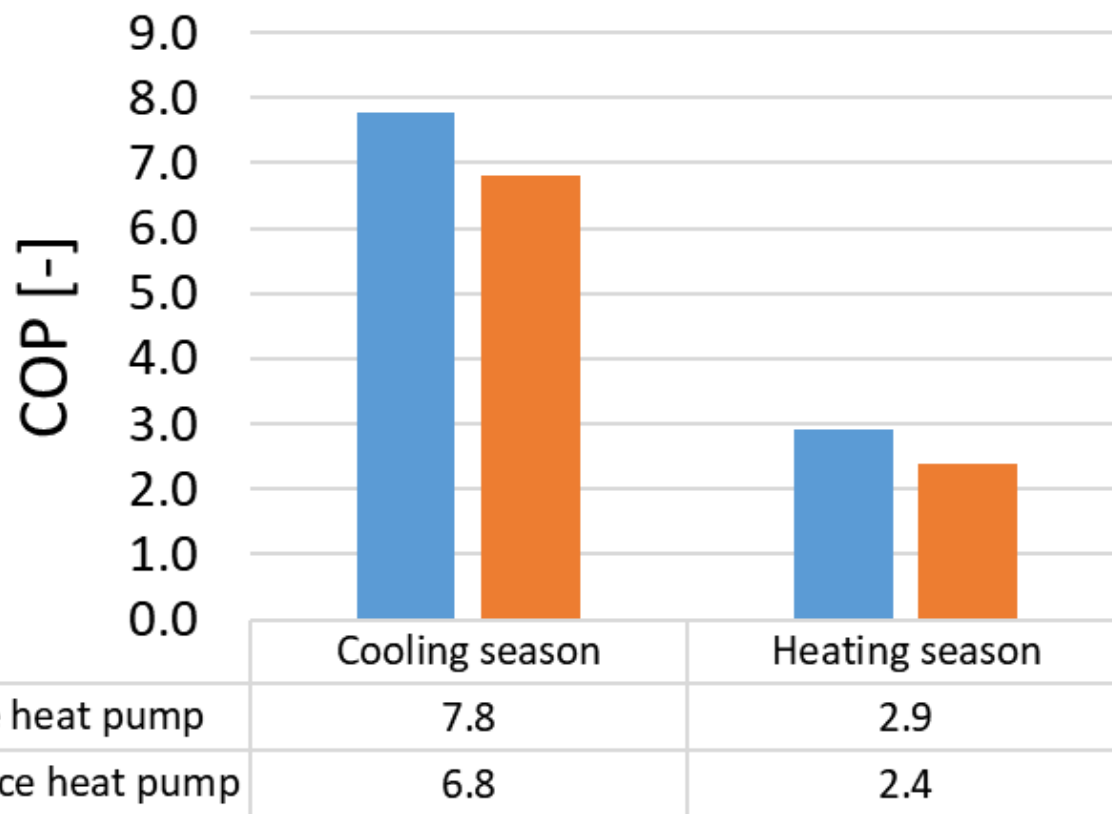

<Seasonal heat pump COP>

- As a result of deriving seasonal COP, the result of high COP of cascade heat pump was derived in each season.
- It is considered to be the result of relatively low compressor energy consumption of the cascade heat pump.



# Simulation result

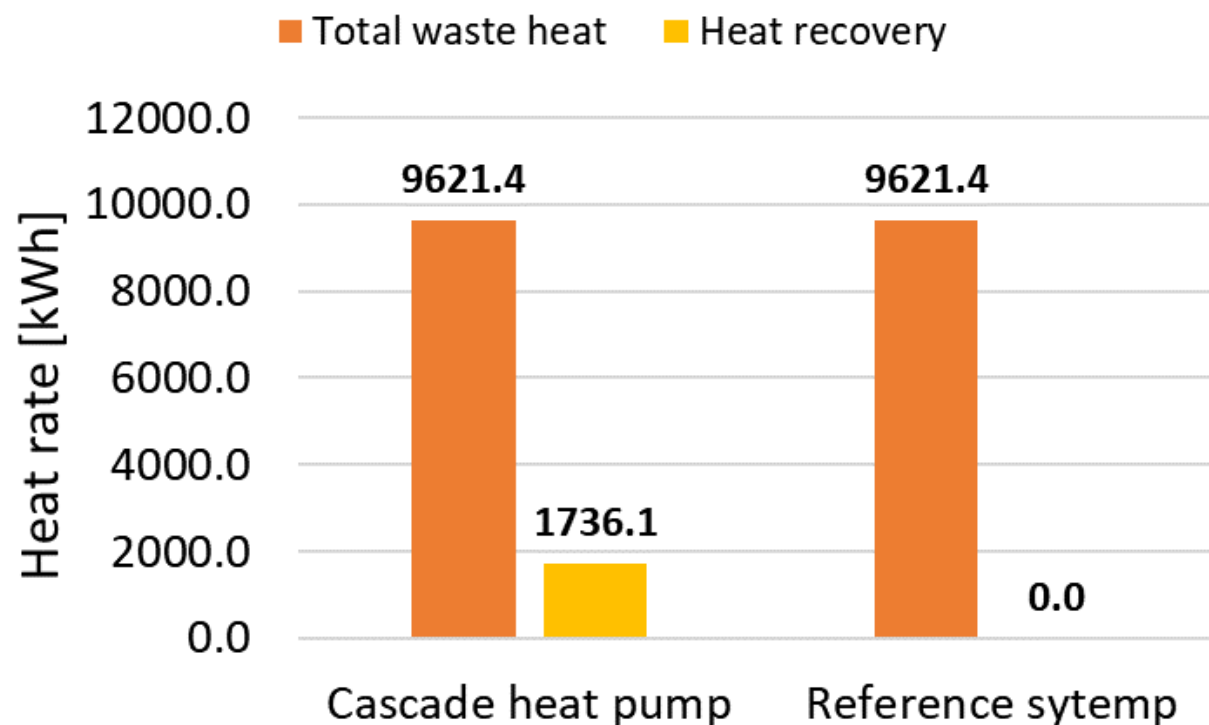

<Amount of recovery heat from low-stage cycle(cooling cycle)>

- The amount of heat released from the condenser of the cooling cycle in summer is 9621.4 kWh.
- Cascade heat pump recovers heat from the low-stage cycle and uses it as a heat source for the high-stage cycle.
  - ✓ About 18% of the waste heat is recovered.

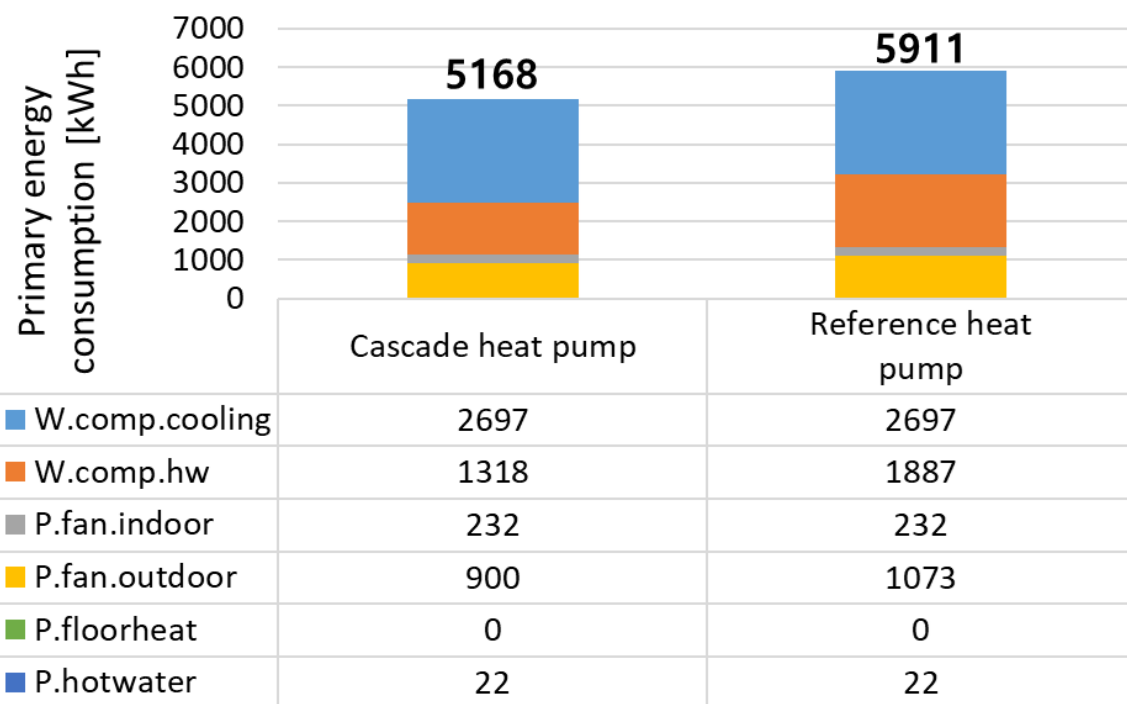

<Energy consumption in cooling season>

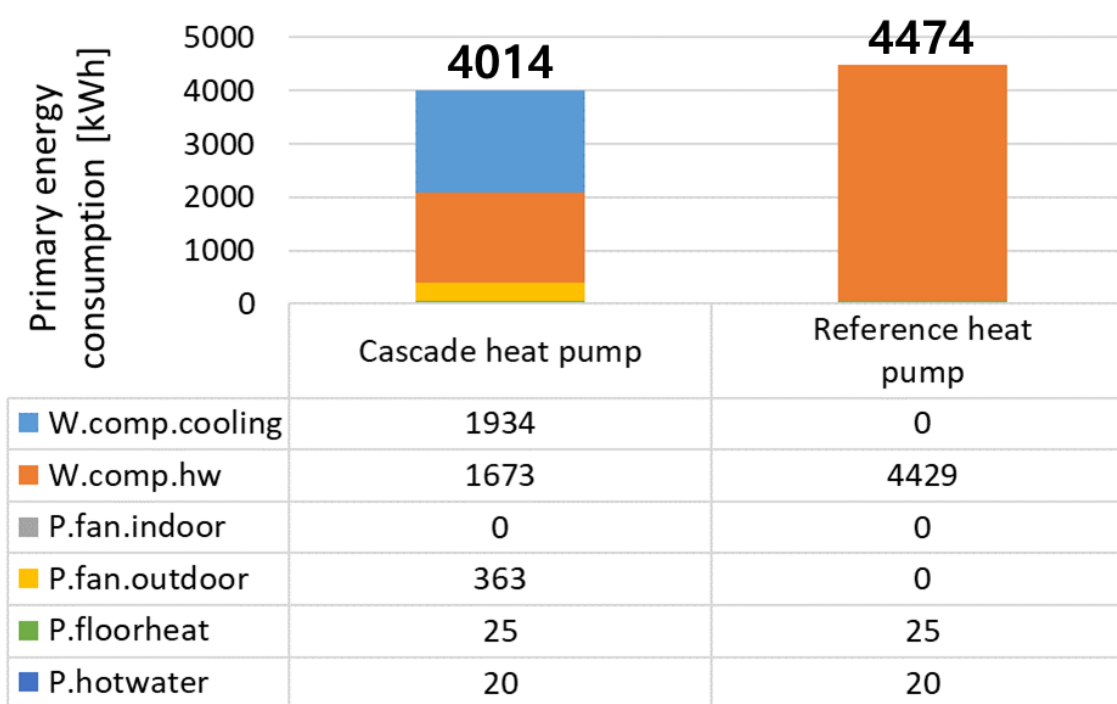

< Energy consumption in heating season >

- The Cascade heat pump shows energy saving effect compared to reference heat pump by 13% in cooling mode and 10% in heating mode

- As a result of the energy simulation, the energy performance of the cascade heat pump is superior to the reference heat pump system.
  - ✓ *Cooling season COP 14%, heating season COP 22% improvement.*
  - ✓ 13% energy save during the cooling season, 10% energy save during the heating season, *total energy savings of 12%.*
- The Cascade heat pump system shows improved performance compared to the reference system (Two single heat pumps).
  - ✓ Reduces the input power requirement for each compressor.
  - ✓ Reducing overall energy consumption.
  - ✓ Increasing system COP.
- Each heat pump compressor requires a small energy load.
  - ✓ *Waste heat recovery* in summer.
  - ✓ *Multi-stage temperature increase* in winter.
- Experimental study should be conducted to validate the energy saving performance of the cascade heat pump system in the future work.



**Thank you for listening**

**bumji21@hanyang.ac.kr**

**Q & A**