

nZEB with GWHP in cold region of Japan

Katsunori Nagano^a, Ye Minzhi^a, Hideki Sato^{b*}

^aHokkaido University, N13-W8, Sapporo 080-8796, Japan

^bSANKEN SETSUBI KOGYO CO., LTD., Kinunodai 4-5-1, Tsukuba Mirai 300-2436, Japan

****Presenter: Prof. Katsunori Nagano***

Hokkaido university, Japan

E-mail address: nagano@eng.hokudai.ac.jp.



The objective of this study

Keywords: nZEB, groundwater source heat pump (GWHP), radiant ceiling panel (RCP), energy conservation, thermal environment;

Evaluation of the nZEB in a cold region in Japan equipped with an open-loop groundwater source heat pump (GWHP) system and radiant ceiling panel (RCP) system

Firstly, the annual energy consumption was calculated based on the recorded measurements.

Secondly, the indoor thermal comfort was evaluated based on the physical measurements and survey questionnaire.

Benefits of the continuous operation method were proved from both the indoor thermal environment and the energy consumption points of views



1. Introduction

Fig. 1 Definition of the four stages of ZEBs in Japan.

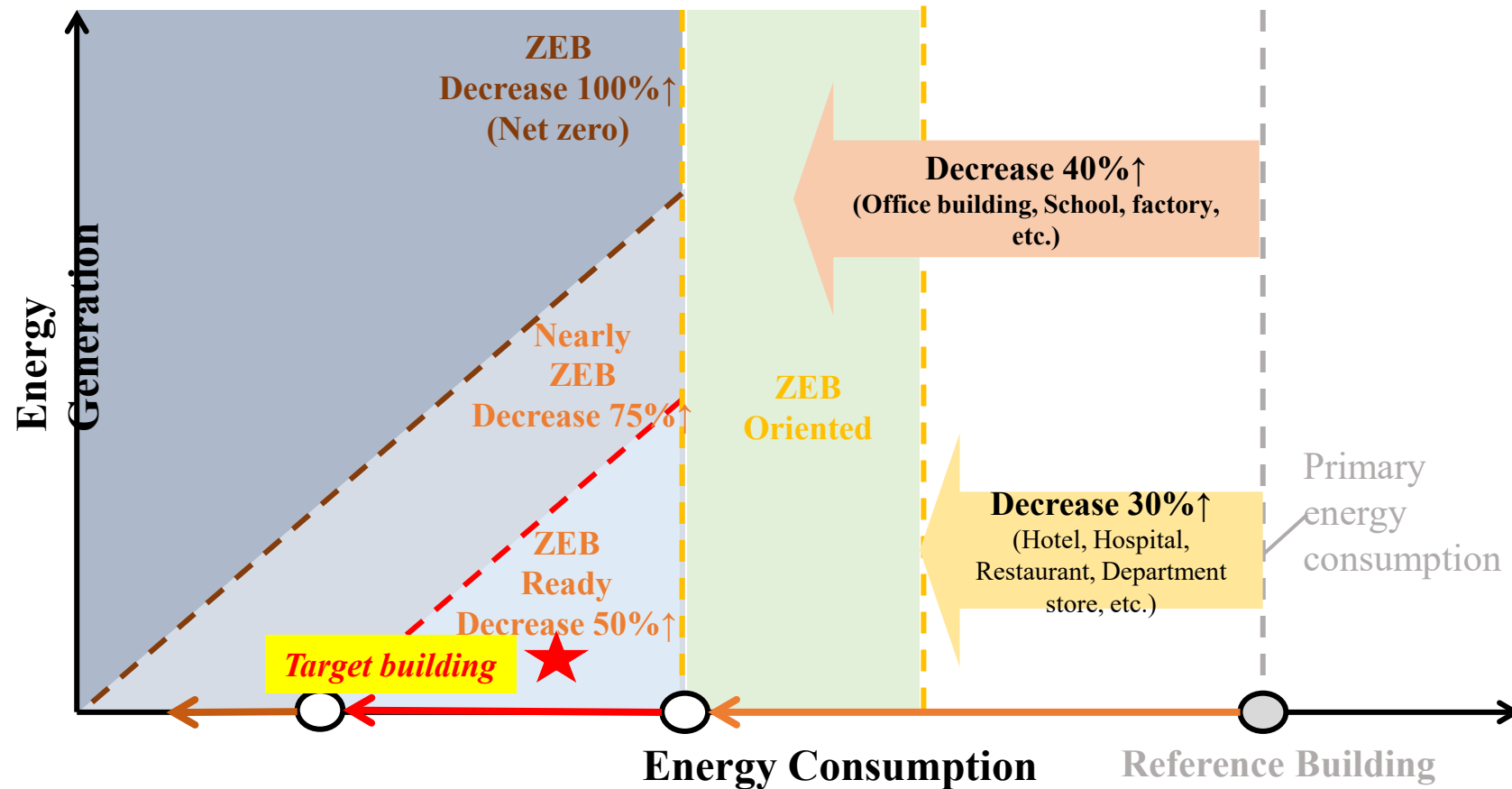

2.1 Building characteristics

Fig. 2 South view and south elevation of the target nZEB.

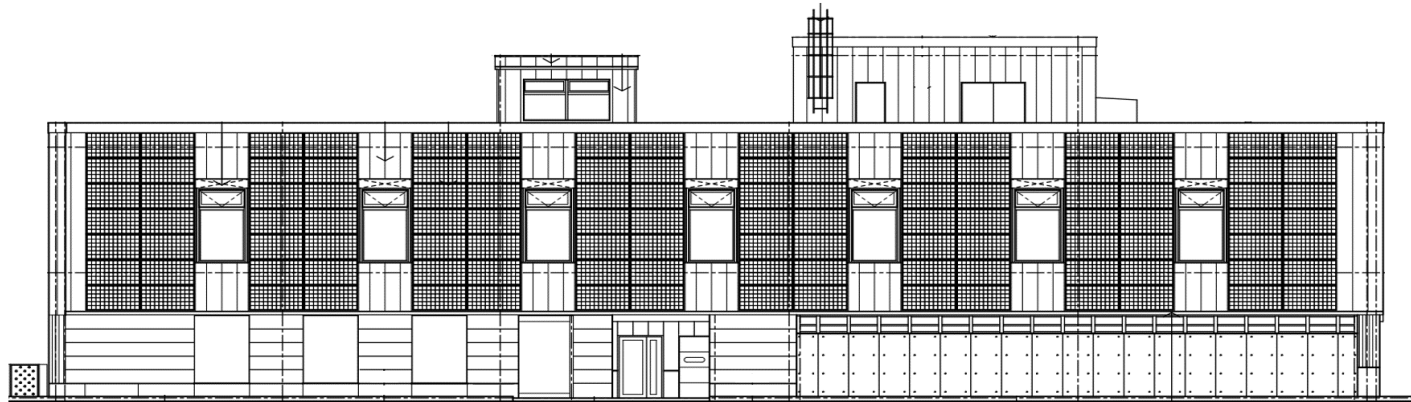

2.1 Building characteristics

Table 1 Thermal conductivities and heat transmission coefficients of the building envelop.

Elements	Material	Thickness [mm]	Heat conductivity λ [W/(m·K)]	Heat transmission coefficient U [W/(m ² ·K)]
Exterior wall	Galvalume	0.4	45	0.24
	Polystyrene foam	110	0.028	
	Concrete	170	1.6	
Roof	Concrete	80	1.6	0.36
	Polystyrene foam	100	0.028	
	Concrete	170	1.6	
	Air layer	-	-	
	Rock wool sound-absorbing board	12	0.17	
Floor	PVC floor tile	3	0.19	0.40
	Concrete	15	1.6	
	Polystyrene foam	50	0.028	
	Air layer	-	-	
	Concrete	310	1.6	
	Base (Rocks)	150	1	
Window	Low-E glass	26	-	1.40

2.2 HVAC systems

Fig. 3 HVAC systems in the target nZEB.

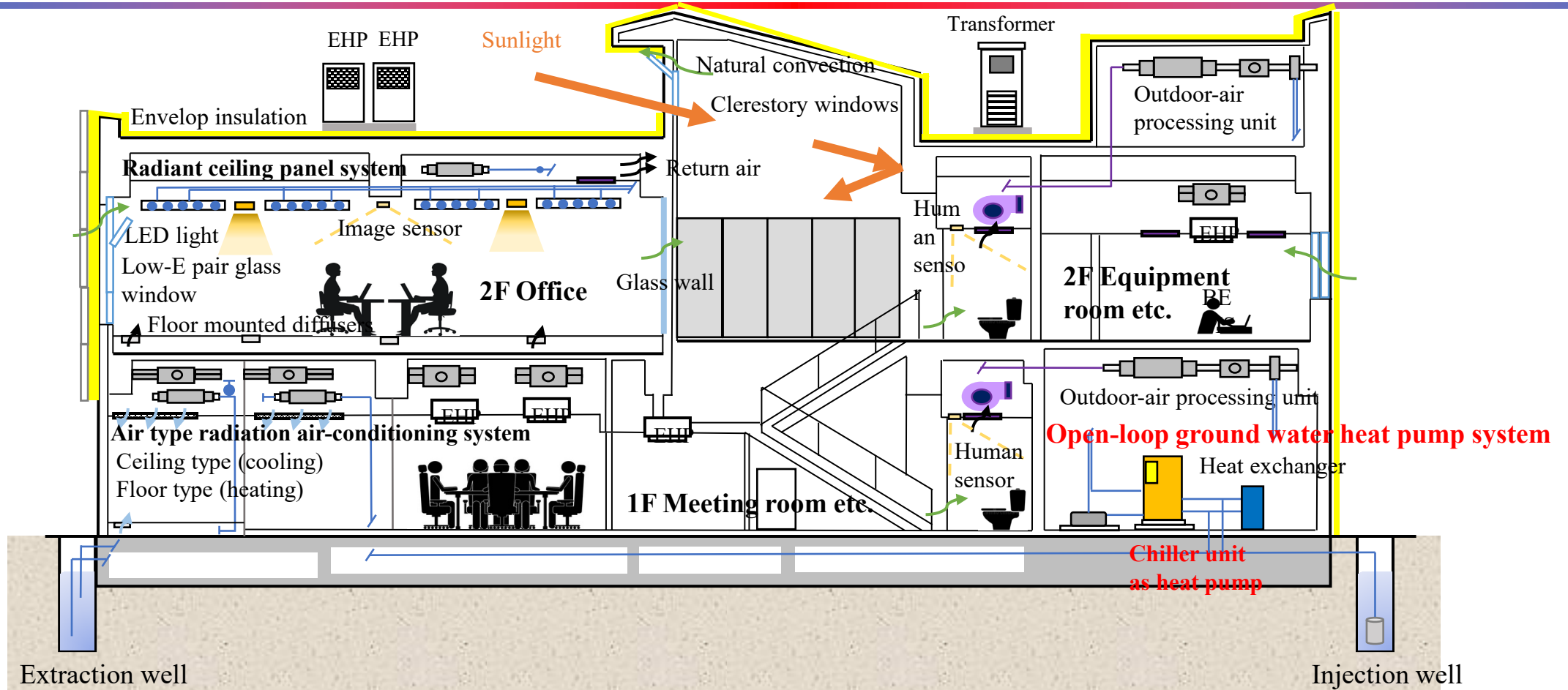

2.2 HVAC systems

Fig. 4 Schematic diagram of an open-loop GWHP system and RCP system for heating and free cooling.

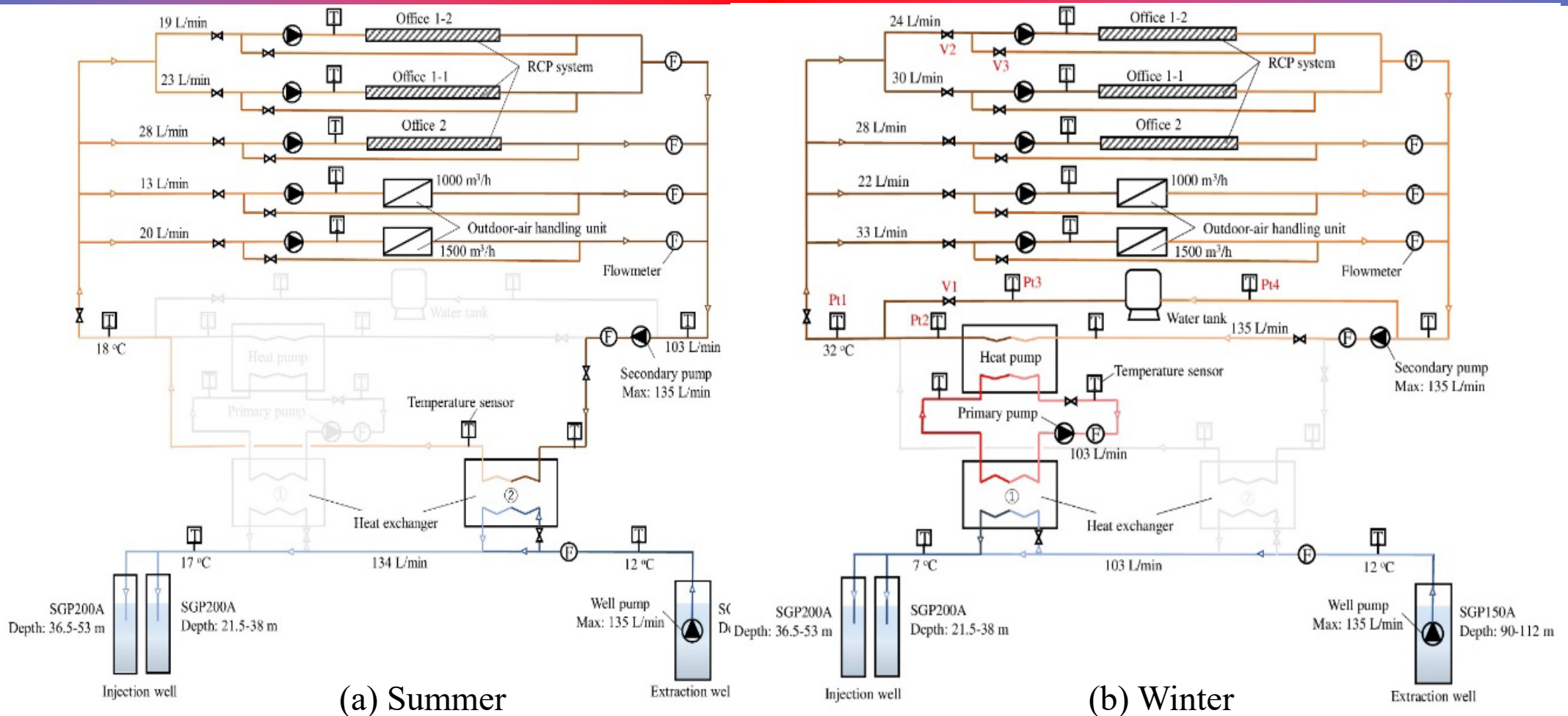

2.3 Indoor space and radiant Ceiling Panels (RCP) for heating and free cooling

Fig. 5 Room inside views and Radiant ceiling panels (RCP) for heating and free cooling.

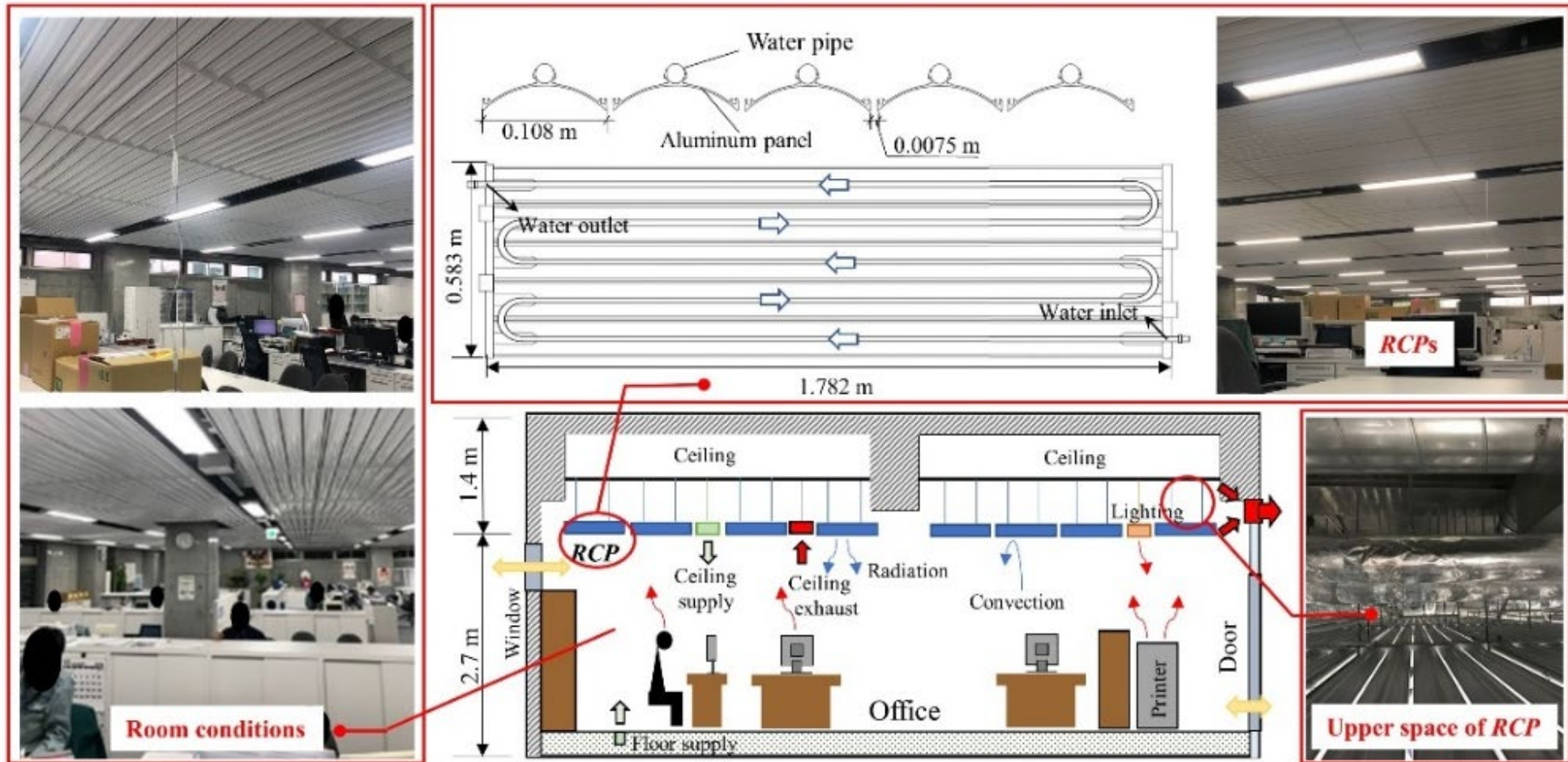

2.3 Indoor space and radiant Ceiling Panels (RCP) for heating and free cooling

Fig. 6 The Plane of the second floor and two RCP groups.

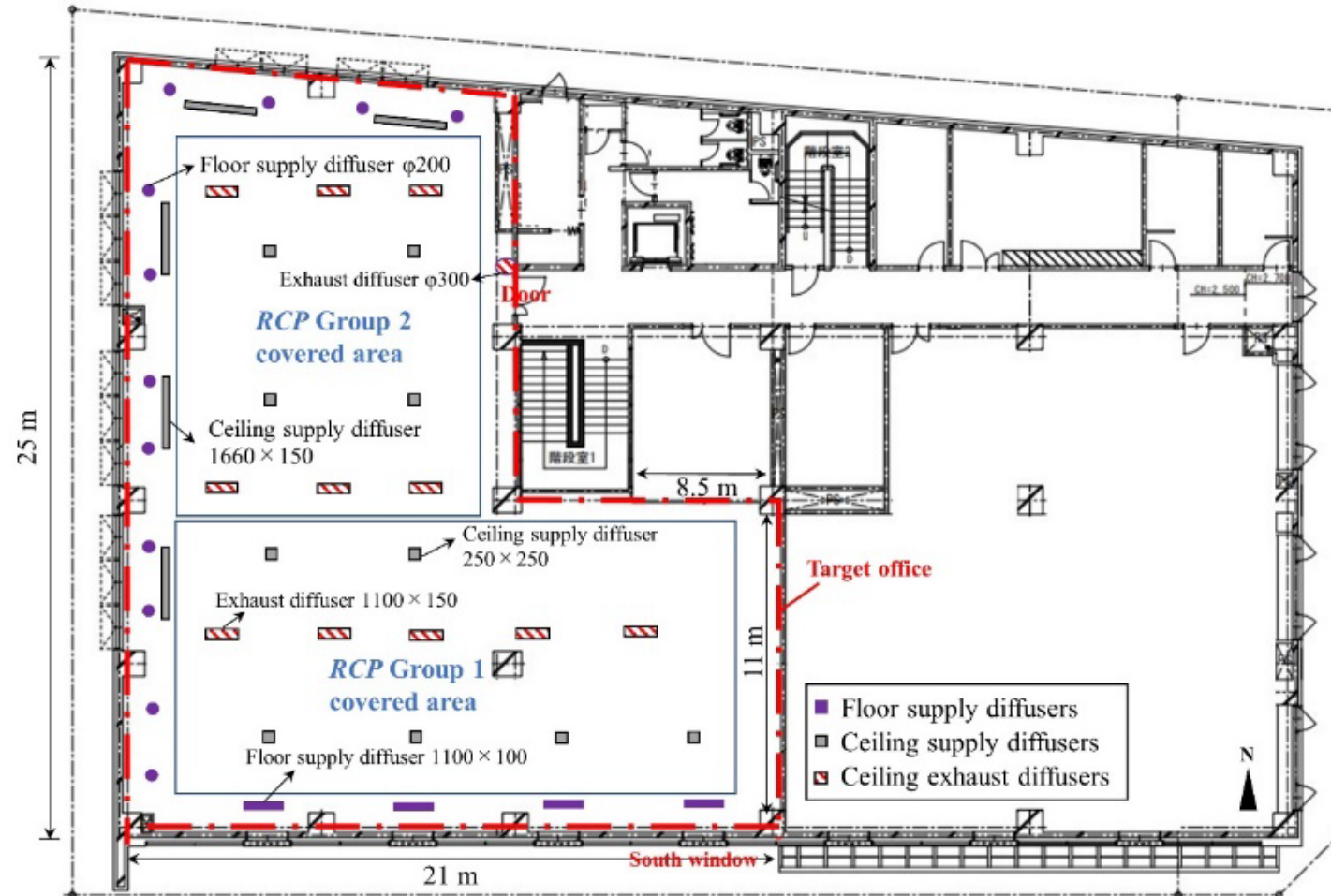

3. Annual energy consumption

Fig. 7 Monthly electric energy consumptions and breakdown of the annual energy consumption (2019).

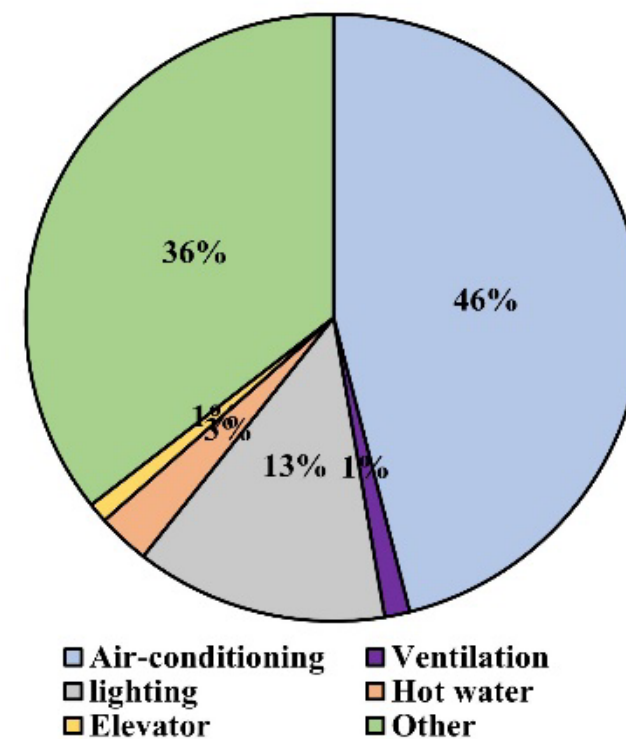
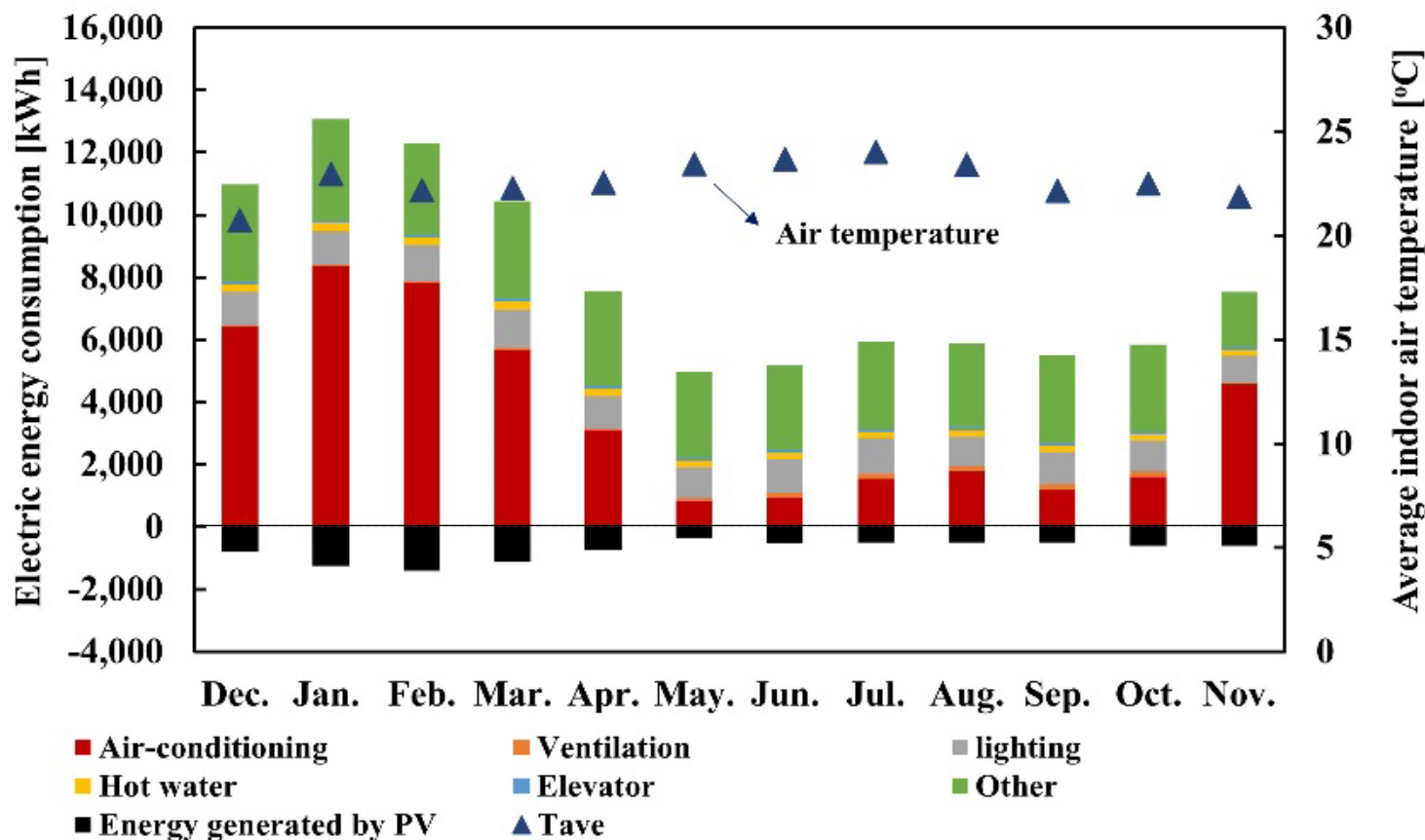

3. Annual energy consumption

Fig. 8 Reduction of the annual energy consumption compared to those of the reference and design phase.

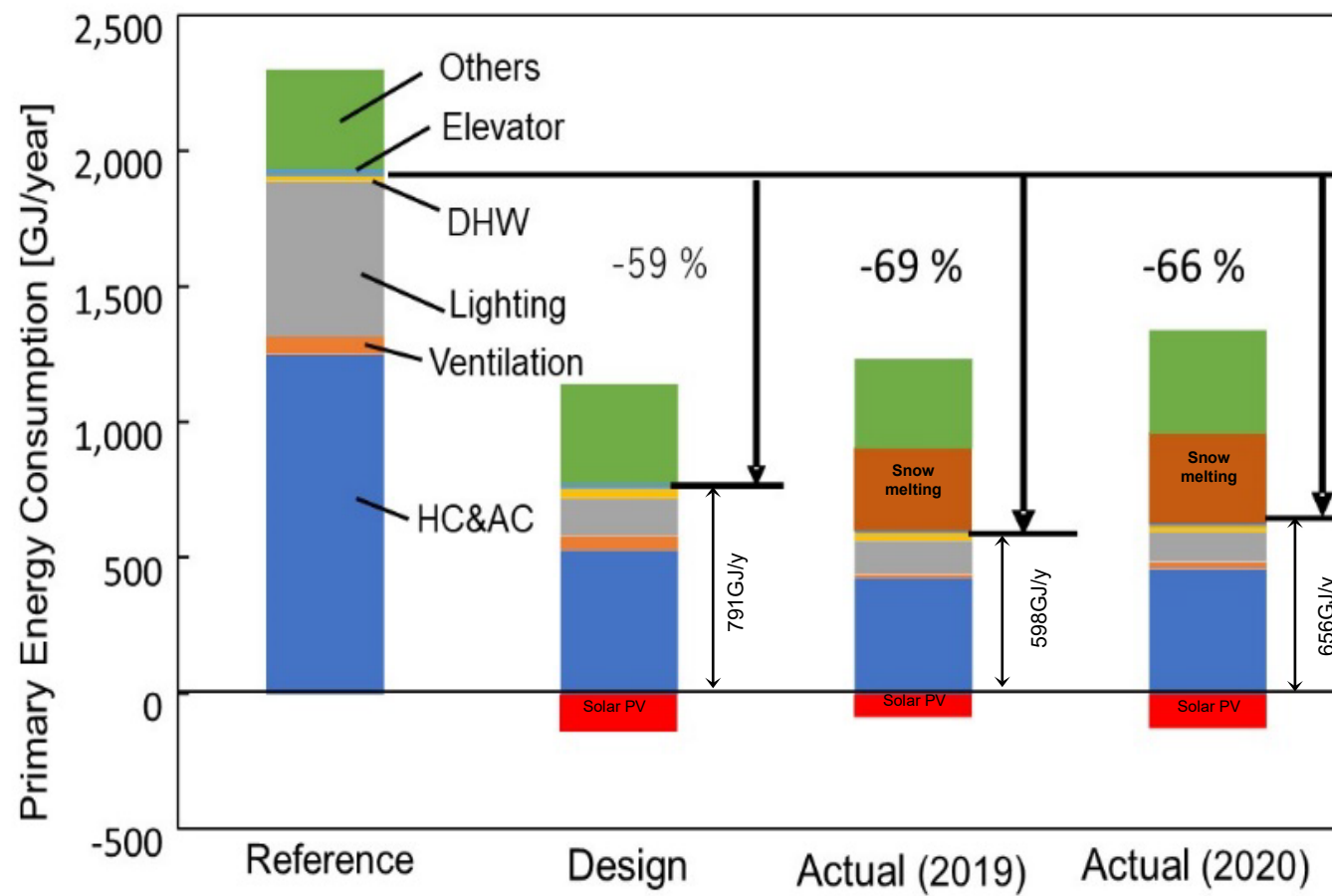



4. Evaluation of the Groundwater source heat pump system (GWHP)

Table 2 Operation status and performance of the groundwater heat source heat pump system (December 2019 – March 2020)



For heating season from December 2019 to March 2020	
Total heating amount of heat pump chiller (1)	42, 772 kWh
Power consumption of heat pump chiller[kWh] (2)	10419 kWh
Power consumption of pumps [kWh] (3) (well/heat source/room/RCP)	993/555/348/1468 kWh
COP of heat pump chiller [-] (1)/(2)	4.11
SCOP of the heat pump/RCP system [-] (1)/[(2)+(3)]	3.62/3.28/3.12
Supply temp. to the RCP	35 °C
Return temp from RCP	29 °C



4. Evaluation of the Groundwater source heat pump system (GWHP)

Fig. 9 Operating conditions of Groundwater source heat pump system and room temperature variations (December 1, 2019 - November 30, 2020).

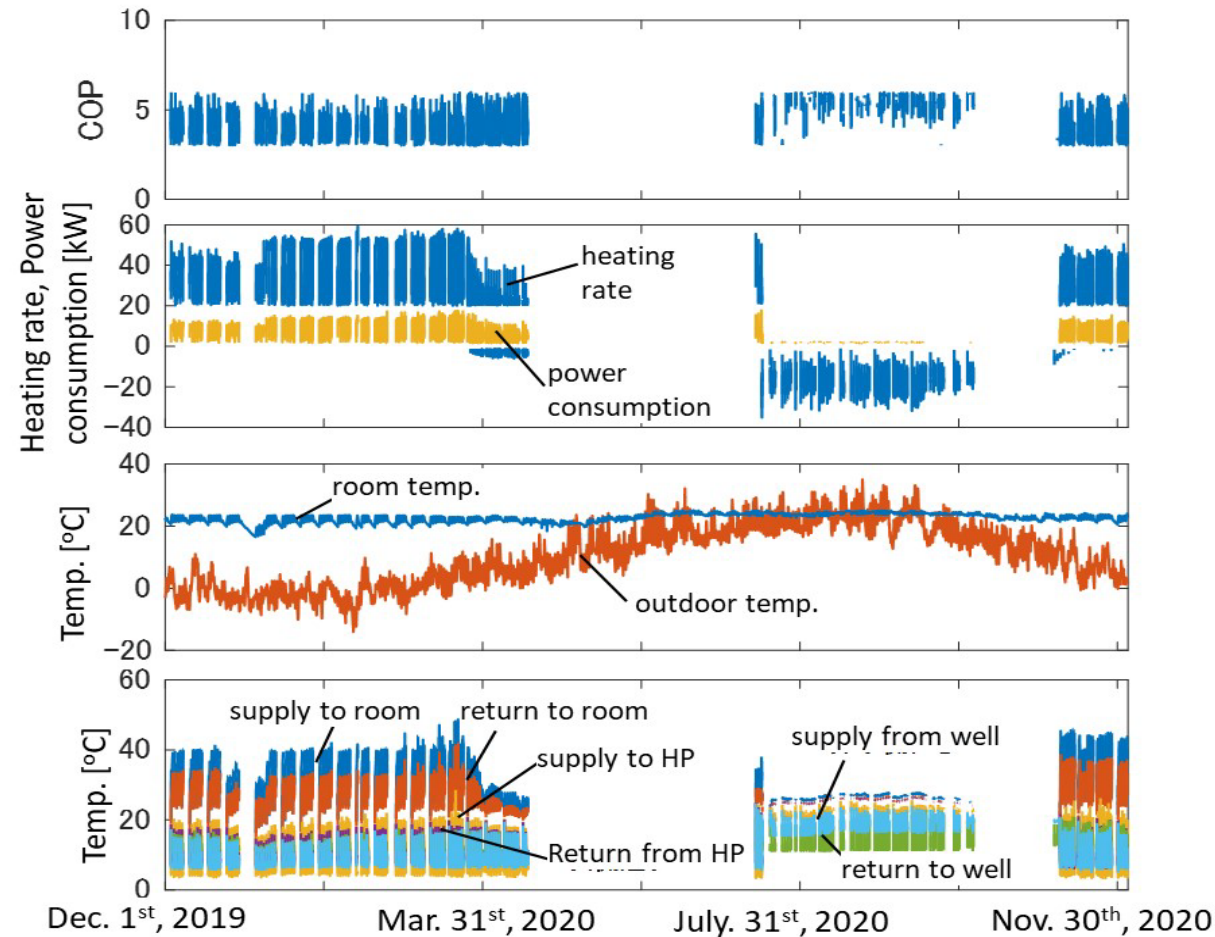

5. Evaluation of vertical room temperature profile

Fig. 10 Variations of average vertical room temperature profile at certain time from February 1 to February 12, 2020

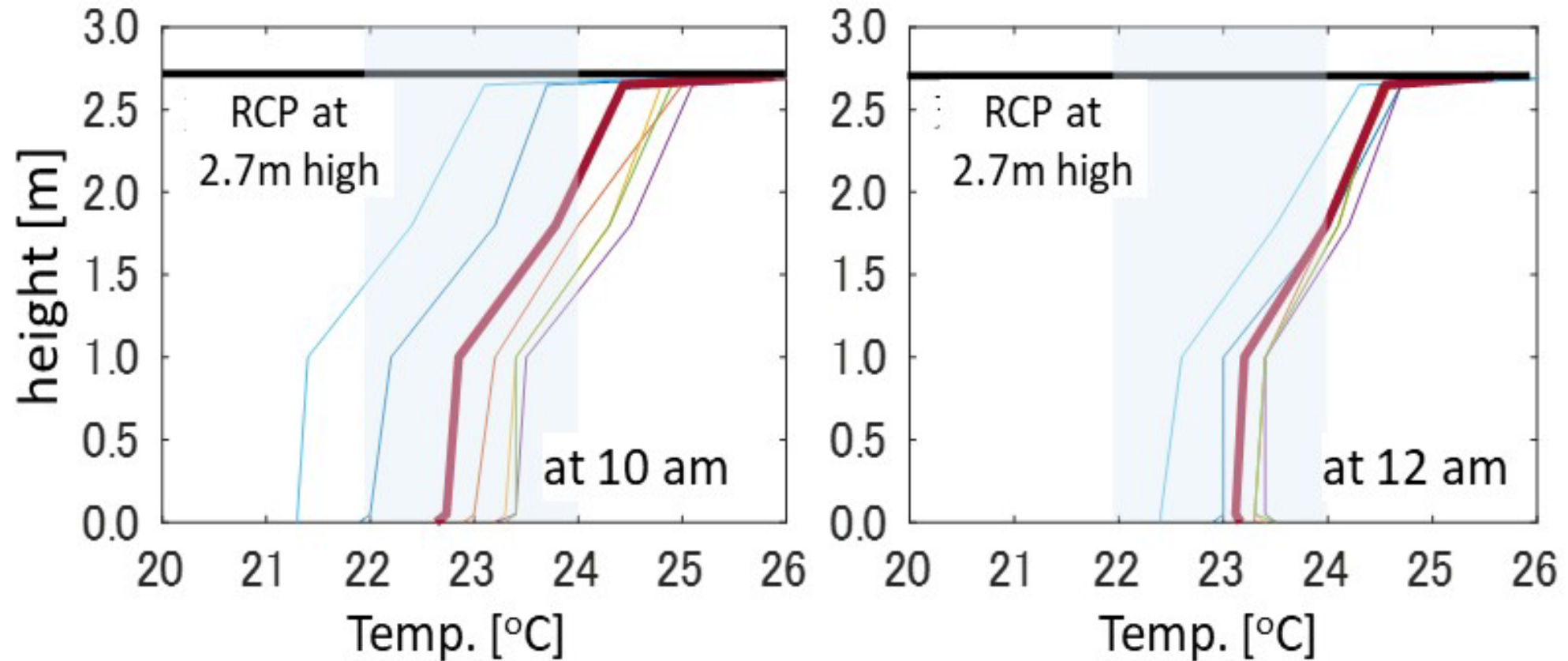



6.1 Evaluation of energy conservation under the continuous heating operation

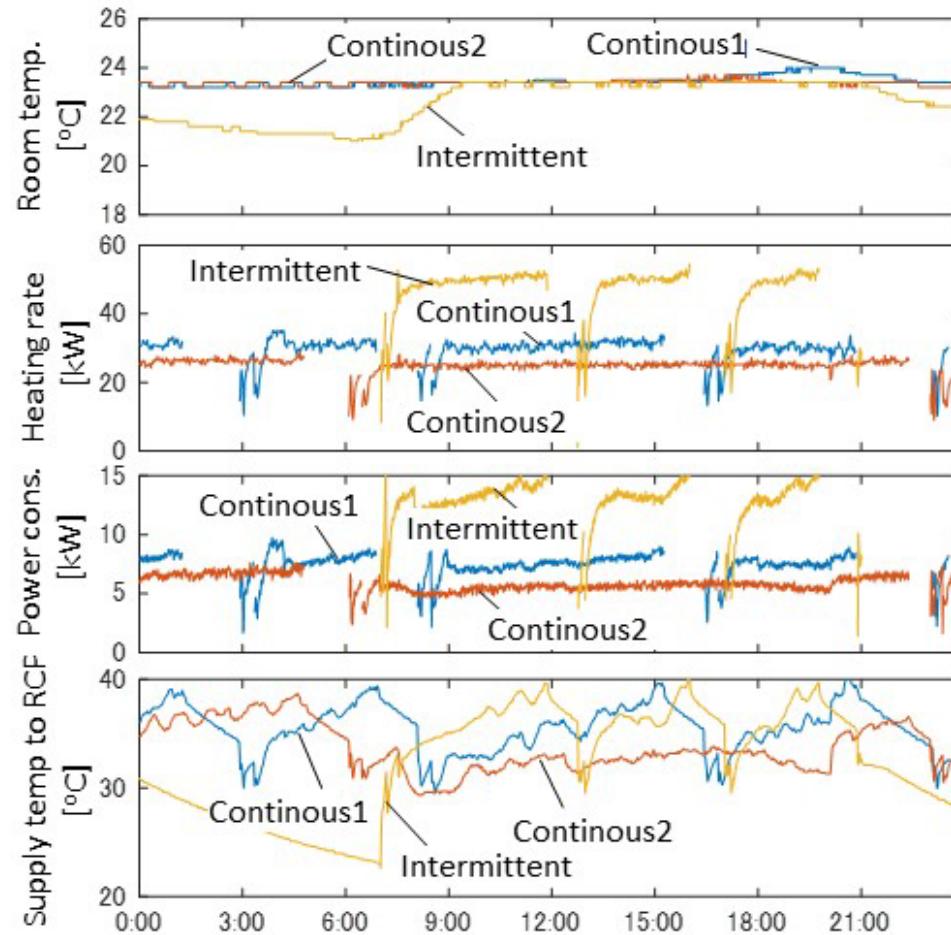

Table 3 Weather conditions during each heating conditions.

	Continuous1	Continuous2	Intermittent
Date	16 th Dec. 2020	15 th Jan. 2021	19 th Jan. 2021
Ave. air temp.[°C]	-4.0	-3.3	-3.0
Max. Temp.[°C]	-2.1	-1.8	-0.6
Min. Temp.[°C]	-6.2	-7.1	-6.6
Sunlight hours [hr]	4.4	1.5	6.0
Global solar radiation [MJ/m ²]	6.76	5.13	8.00
Snow fall depth [cm]	4	-	4

6.1 Evaluation of energy conservation under the continuous heating operation

Fig. 11 Variations of room temperatures and power consumptions for three operations





6.2 Evaluation of thermal sensation under the continuous heating operation

Table 3 Weather conditions during each heating conditions.



Sex		Male	Female
Total number of persons		19	4
Age/ persons	> 50	10	1
	40-50	5	1
	30-40	0	0
	20-30	5	2
Height / cm	Average	170	156
Weight / kg	Average	68	57



6.2 Evaluation of thermal sensation under the continuous heating operation

Fig. 12 Daily distributions of thermal sensation (1) and comfort sensation (2)



(1) Thermal sensation

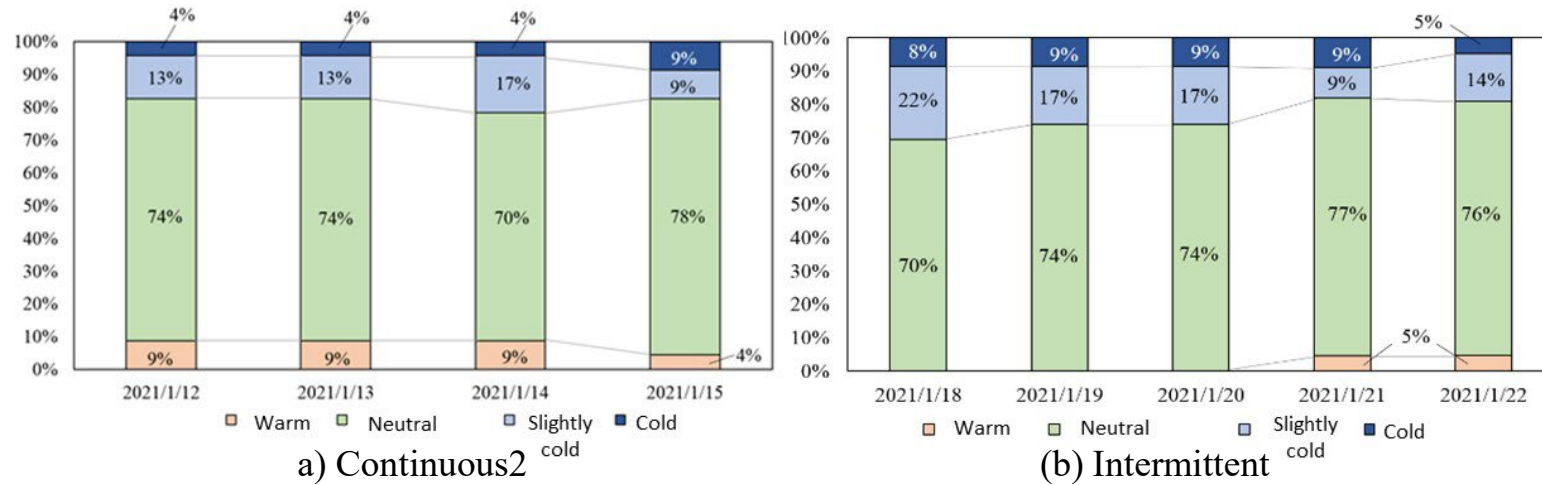

(2) Comfort sensation

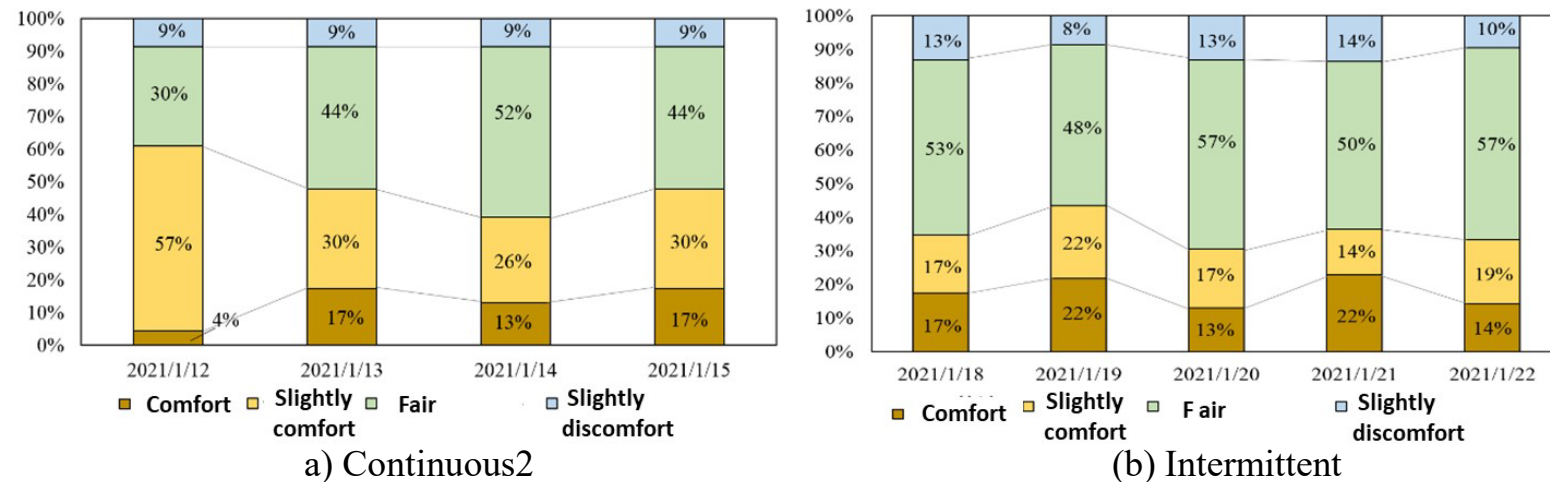

Conclusions

- 1) The building performance of the nZEB in a cold region in Hokkaido equipped with an open-loop groundwater source heat pump (GWHP) system and a radiant ceiling panel (RCP) was evaluated
- 2) The primary energy consumption can be decreased by approximately 67% compared to that of the reference building by applying this system.
- 3) It was shown this building could reach the ZEB-ready level from the measurement.
- 4) The results showed that the suspended RCP system could achieve comfortable indoor thermal conditions during the year. The indoor temperature was maintained within the range of 22–26 °C.
- 5) Both energy consumption and thermal comfort of the continuous heating was compared to those of the intermittent operation. More stable indoor thermal environment was maintained and the COP and SCOP of the GWHP system was increased by 12%.