

Innovative gas-driven absorption heat pump prototype for space heating and domestic hot water production

POLITECNICO
MILANO 1863



Giorgio Villa | Politecnico di Milano - Department of Energy

The **largest heating market** in Europe is the **retrofit segment**, where low-efficient heating systems are installed.

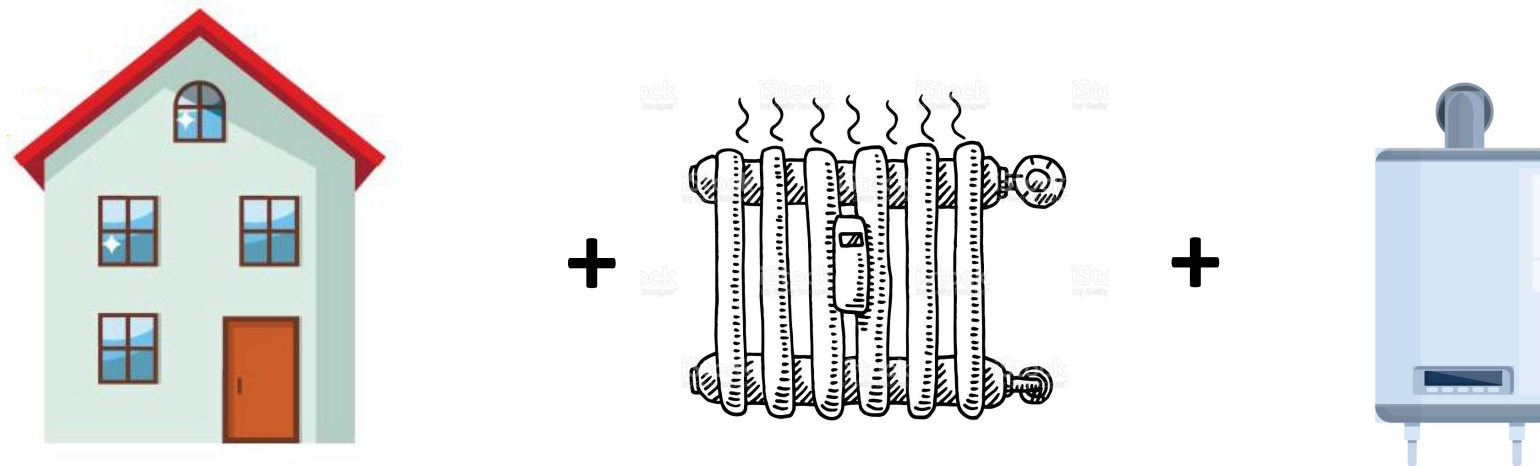

Current solutions based on Electric Heat Pumps (EHP) might not be sufficient to completely fulfill this task. **Gas Absorption Heat Pump (GAHP)** is an interesting solution that guarantee **high efficiency** and **high power even in high-temperature applications**.

The **largest heating market** in Europe is the **retrofit segment**, where low-efficient heating systems are installed.

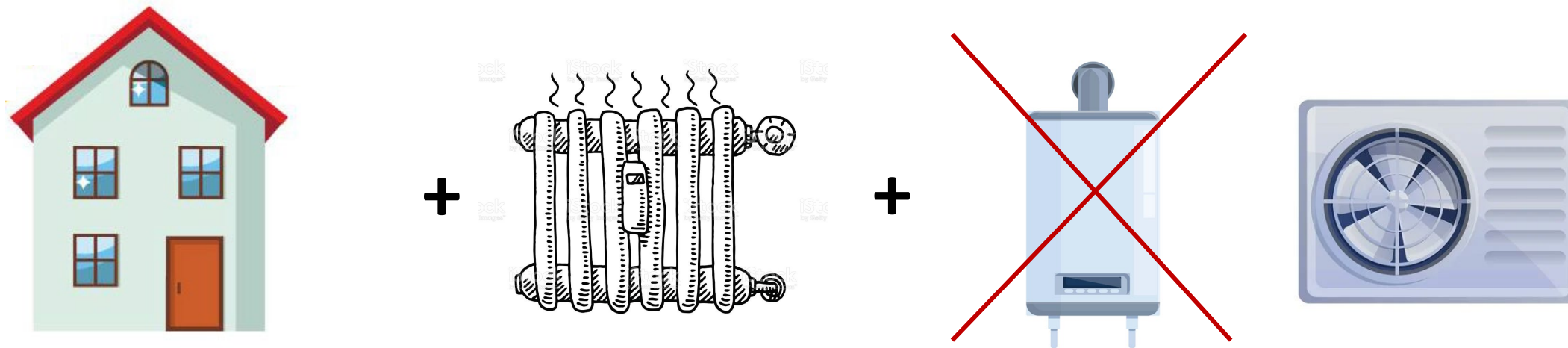

Current solutions based on Electric Heat Pumps (EHP) might not be sufficient to completely fulfill this task. **Gas Absorption Heat Pump (GAHP)** is an interesting solution that guarantee **high efficiency** and **high power even in high-temperature applications**.



+

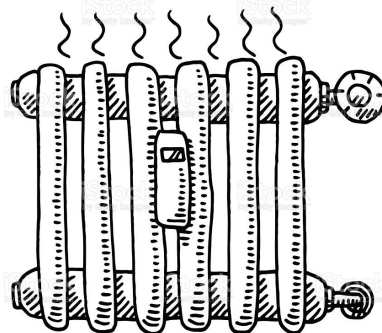

+



Gas driven heat pump

Advantages of GHP technology

1. Limited performance degradation with **high supply water temperatures**
2. Limited **noise** (no mechanical compressor and relatively small outdoor heat exchanger)
3. Natural refrigerants: **zero** Ozone Depletion Potential and **zero** Global Warming Potential (GWP)
4. Negligible impact on the **electric grid**

Goal: Development of a compact 10 kW gas-driven ammonia-water absorption heat pump (GAHP) for space heating and domestic hot water production.

Objectives:

- Heat pump suitable for the retrofit market
- High efficiency in typical working conditions
- Easy to industrialize
- Easy to scale to different capacities
- Suitable for different compact installation configuration.
Minimum impact from the user perspective

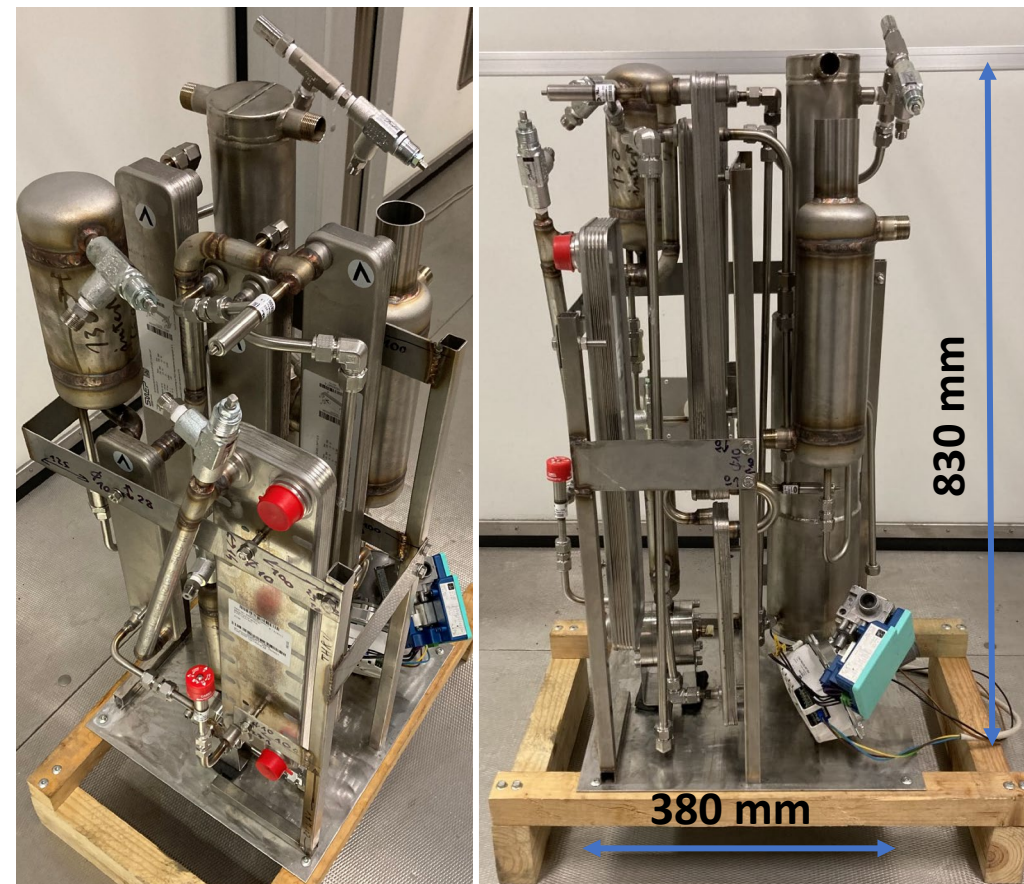

Heat pump features:

- Single effect cycle with ammonia-water as working fluids
- Capacity: 10 kW at nominal conditions ($T_{\text{air}} = -10^{\circ}\text{C}$ and $T_{\text{water}} = 55^{\circ}\text{C}$)
- Maximum supply water temperature 70°C
- Variable electronic expansion valves, both on the refrigerant and ammonia-water solution circuit, **to maximize efficiency**
- Special generator layout and water cooled rectification, (**patents pending**)
- Use of regular plate heat exchangers
- Secondary brine loop to transfer heat from external air to the evaporator (minimal capacity loss during defrosting and flexible installation layout)

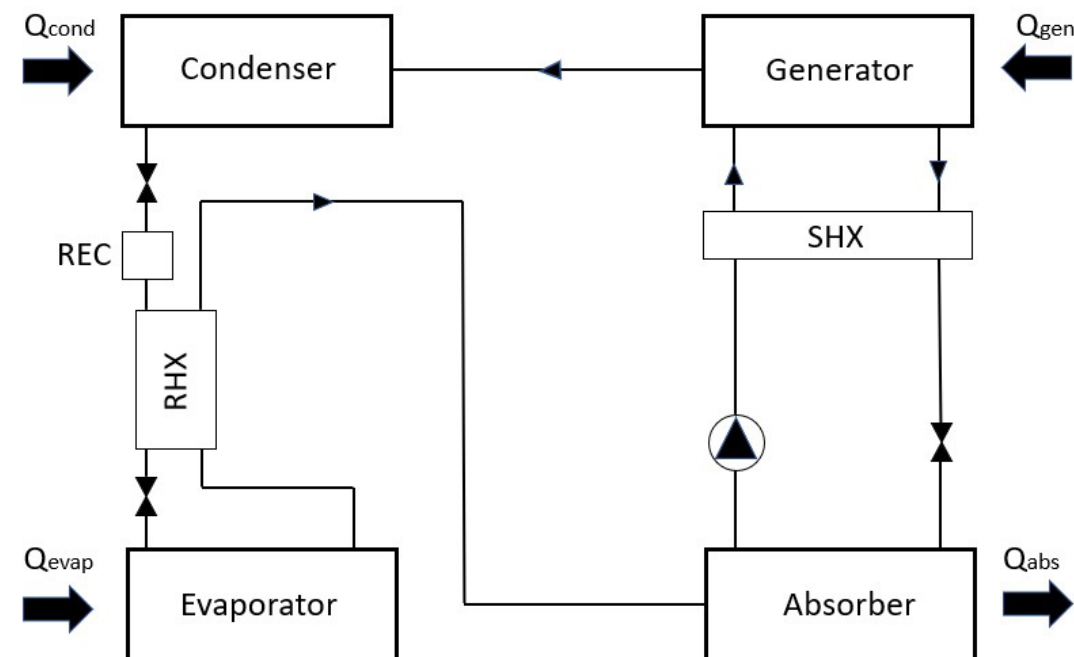

Heat pump features:

- Single effect cycle with ammonia-water as working fluids
- Capacity: 10 kW at nominal conditions ($T_{\text{air}} = -10^{\circ}\text{C}$ and $T_{\text{water}} = 55^{\circ}\text{C}$)
- Maximum supply water temperature 70°C
- Variable electronic expansion valves, both on the refrigerant and ammonia-water solution circuit, **to maximize efficiency**
- Special generator layout and water cooled rectification, **(patents pending)**
- Use of regular plate heat exchangers
- Secondary brine loop to transfer heat from external air to the evaporator (minimal capacity loss during defrosting and flexible installation layout)

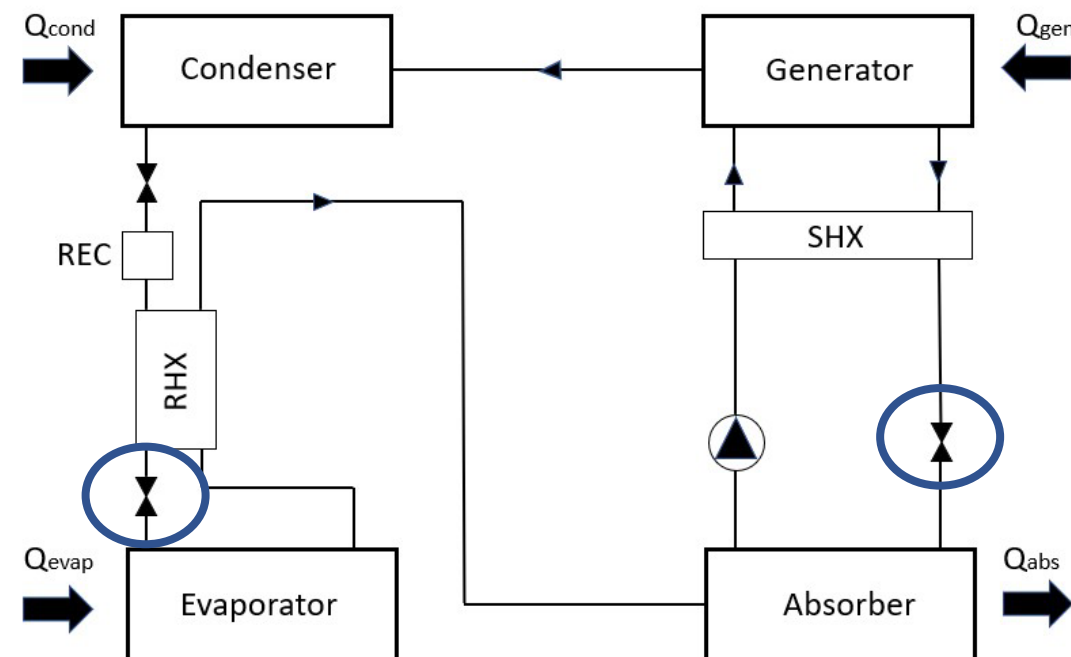

Heat Exchangers

Standard Stainless steel plate heat exchangers (PHE)

- High surface area density → **low weight and volume**
- Suitable for large scale production
- Specific channel configuration to achieve the maximum thermal length



Solution pump

Oil driven diaphragm pump specifically designed for this application. Life service free





Design solution of the generator

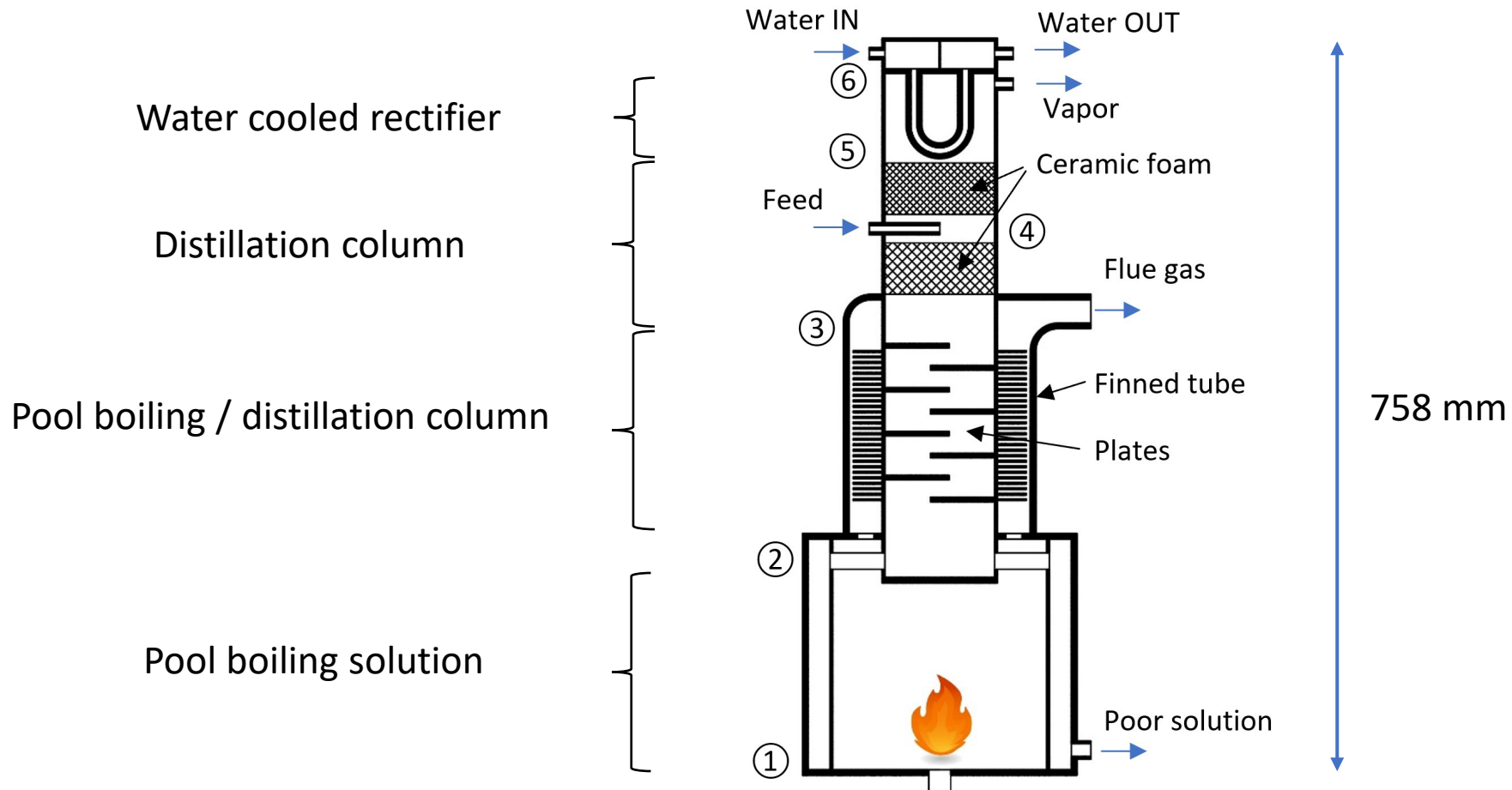

Patents

[WO2023285364A1](https://patents.google.com/patent/WO2023285364A1)

[WO2023285381A1](https://patents.google.com/patent/WO2023285381A1)

[WO2023285385A1](https://patents.google.com/patent/WO2023285385A1)



Design solution of the generator

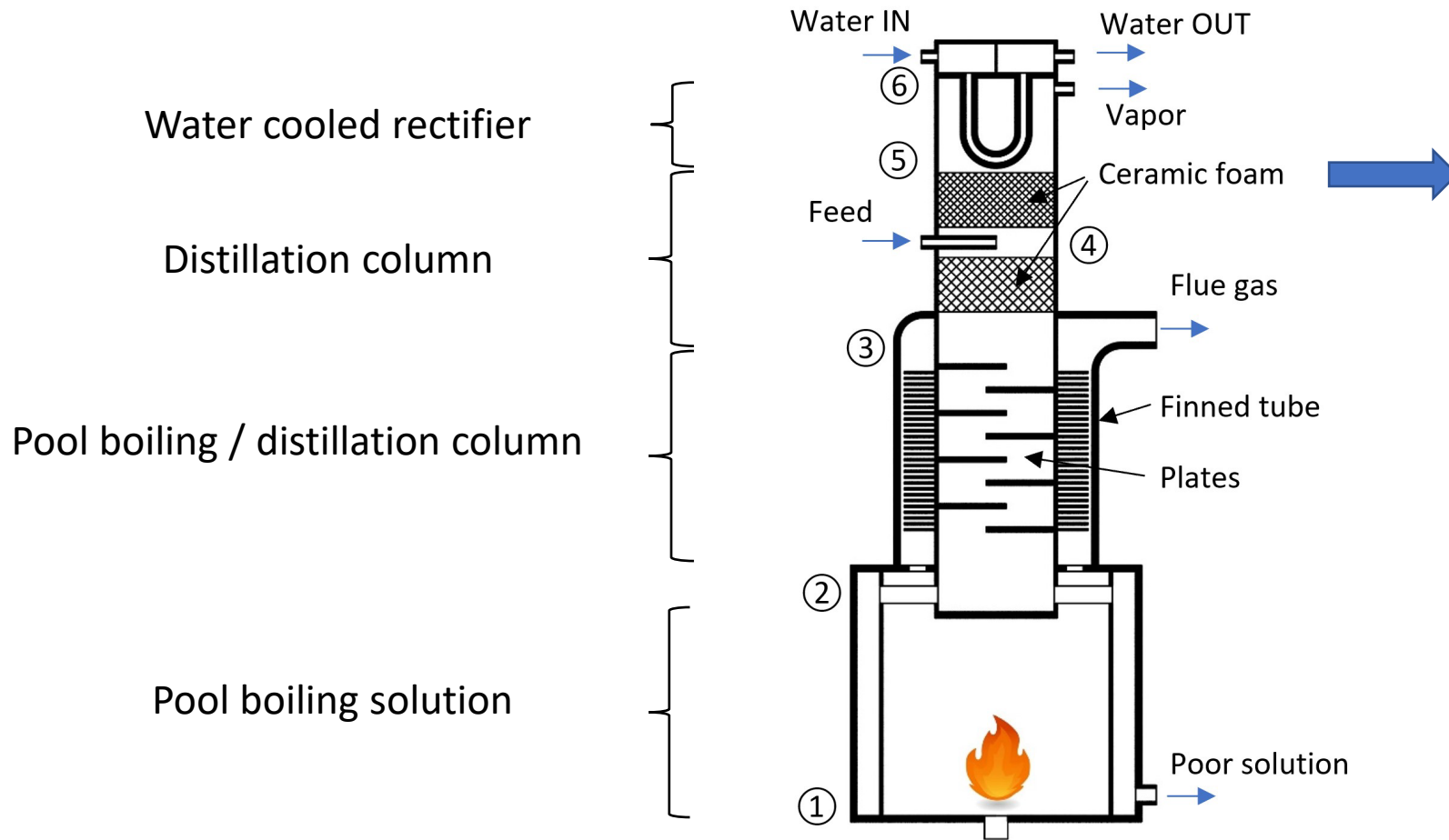



Design solution of the generator

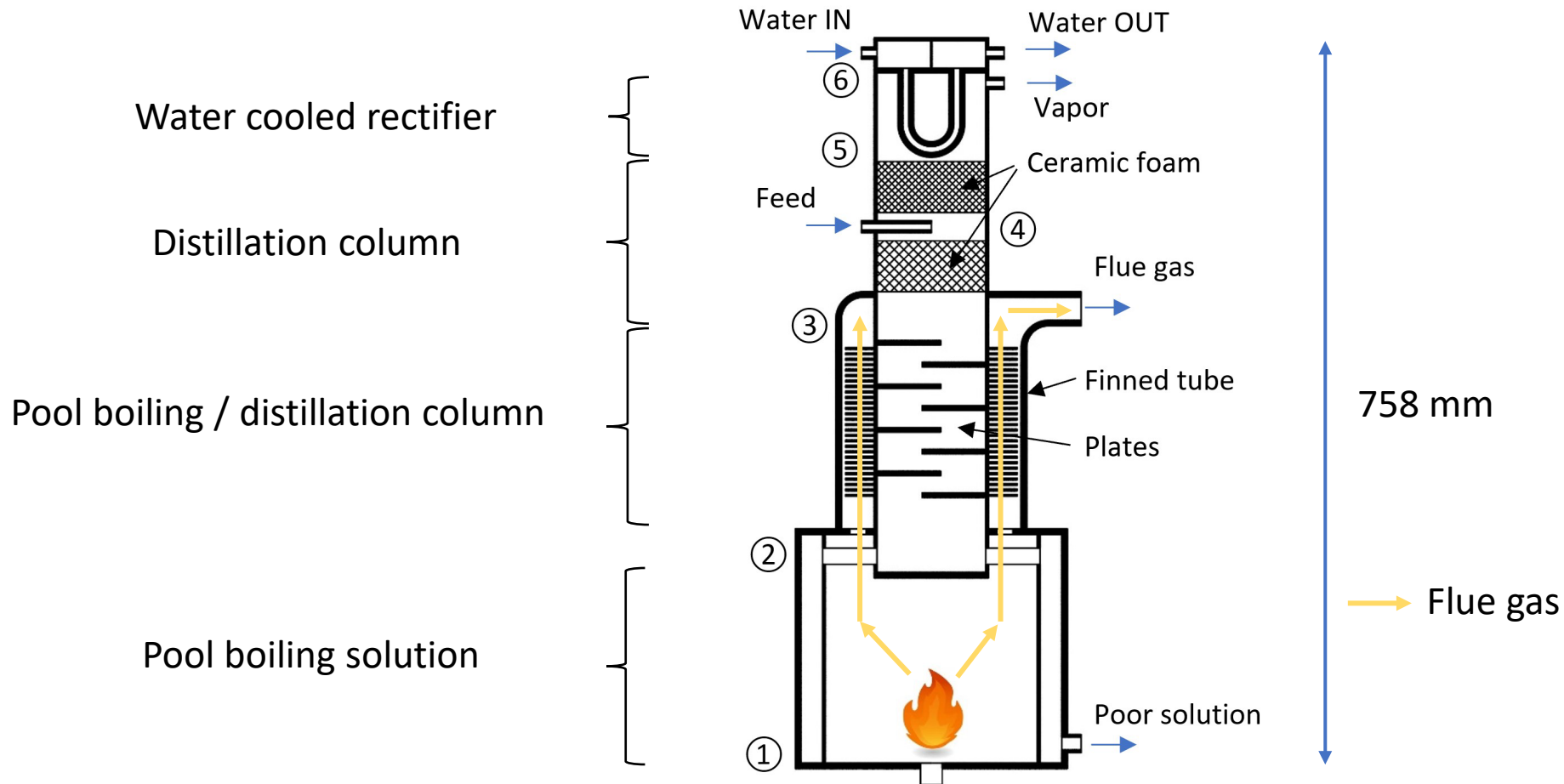

Patents

[WO2023285364A1](https://patents.google.com/patent/WO2023285364A1)

[WO2023285381A1](https://patents.google.com/patent/WO2023285381A1)

[WO2023285385A1](https://patents.google.com/patent/WO2023285385A1)



Design solution of the generator

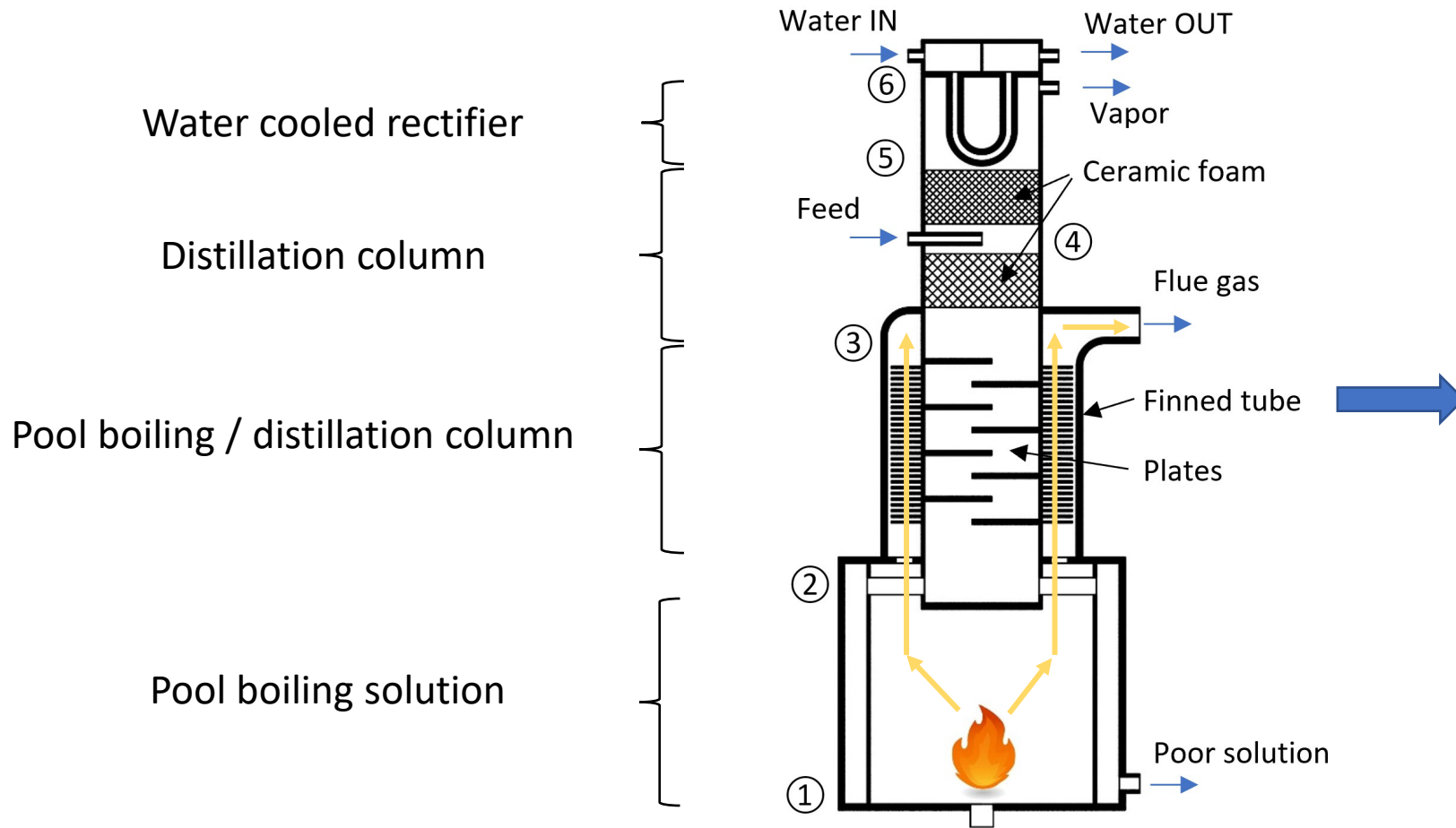

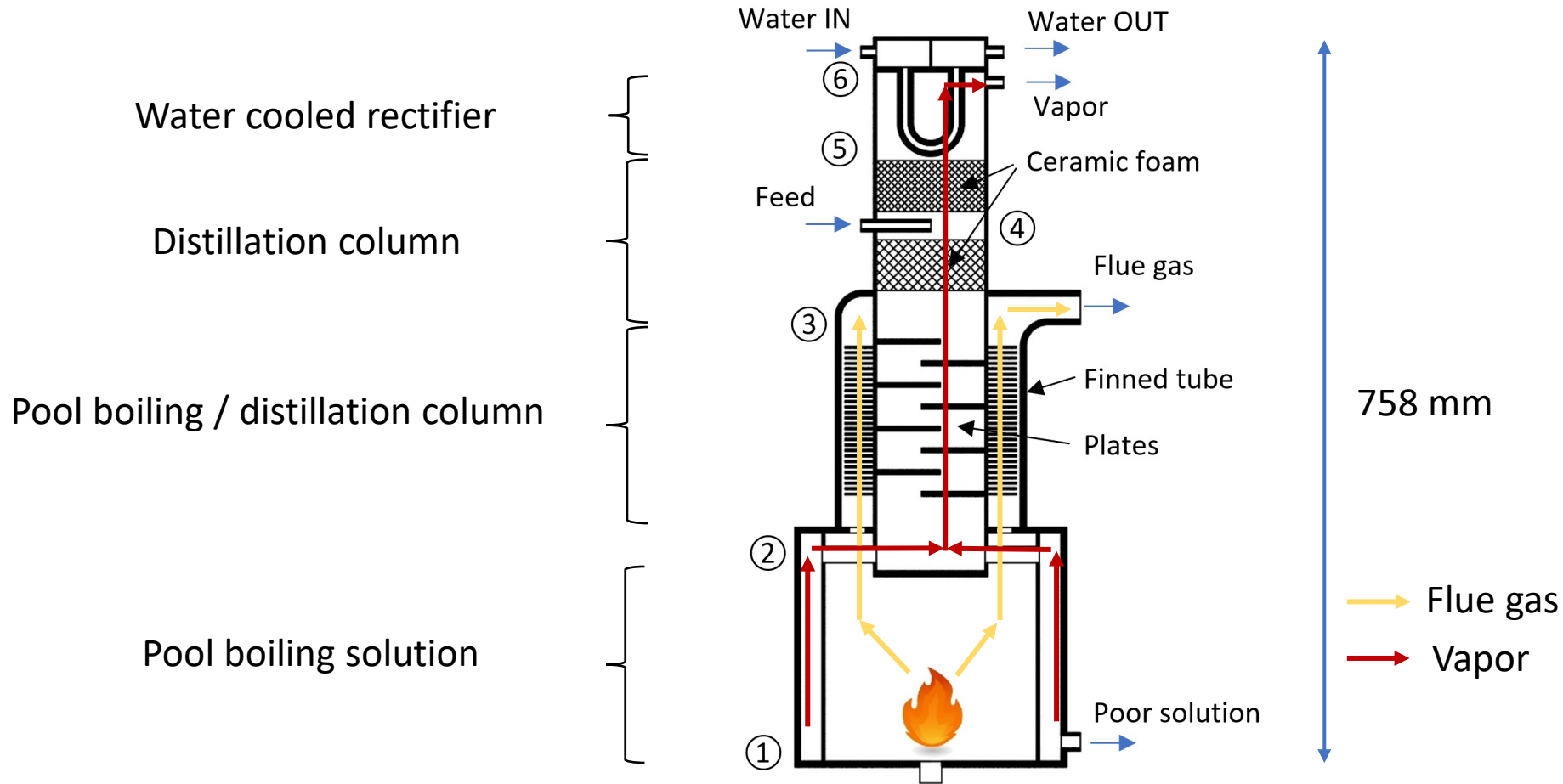

Patents

[WO2023285364A1](https://patents.google.com/patent/WO2023285364A1)

[WO2023285381A1](https://patents.google.com/patent/WO2023285381A1)

[WO2023285385A1](https://patents.google.com/patent/WO2023285385A1)



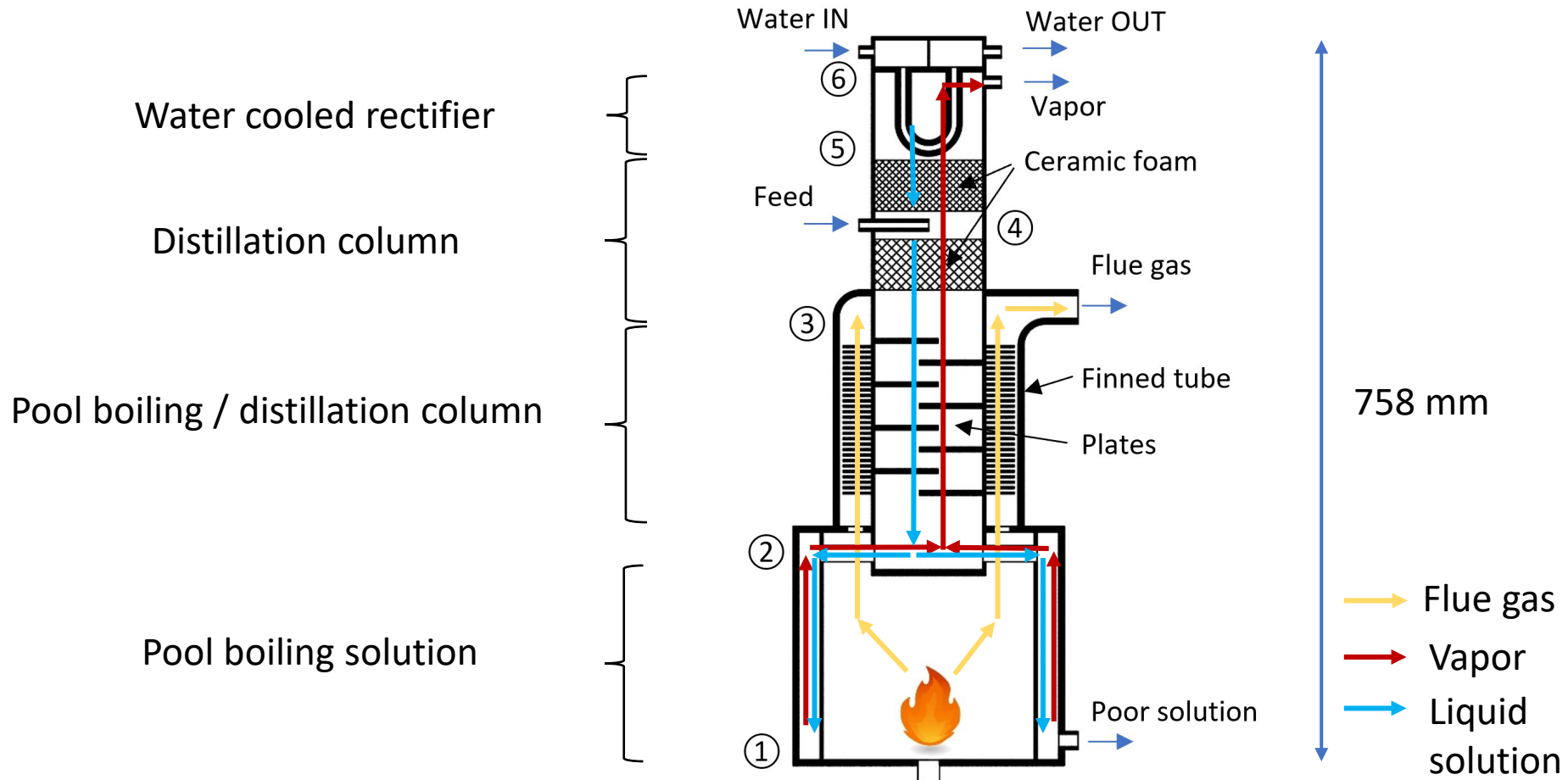

Patents

[WO2023285364A1](https://patents.google.com/patent/WO2023285364A1)

[WO2023285381A1](https://patents.google.com/patent/WO2023285381A1)

[WO2023285385A1](https://patents.google.com/patent/WO2023285385A1)



Solution cooled rectifier (most used solution)

- Internal heat recovery **High** → Rectifier + SHX
- mass flow rate **Low** → Rich Solution
- Compactness **Limited** → Large area of the rectifier

Water cooled rectifier

- Internal heat recovery **Limited** → **High** with an Effective SHX
- mass flow rate **High** → Water
- Compactness **High**

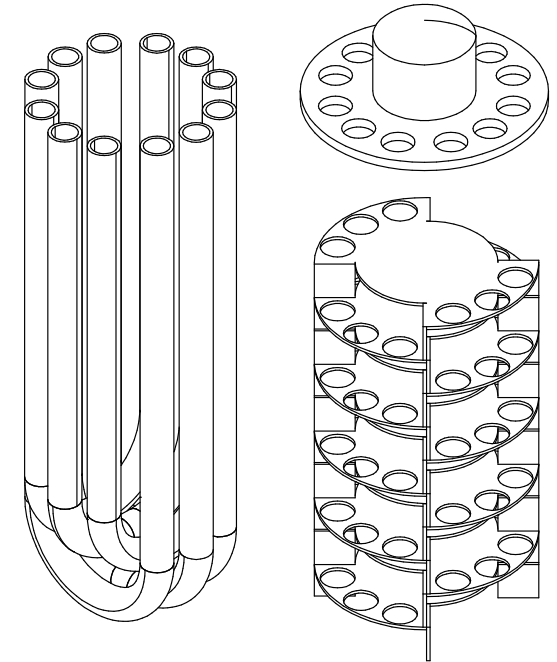
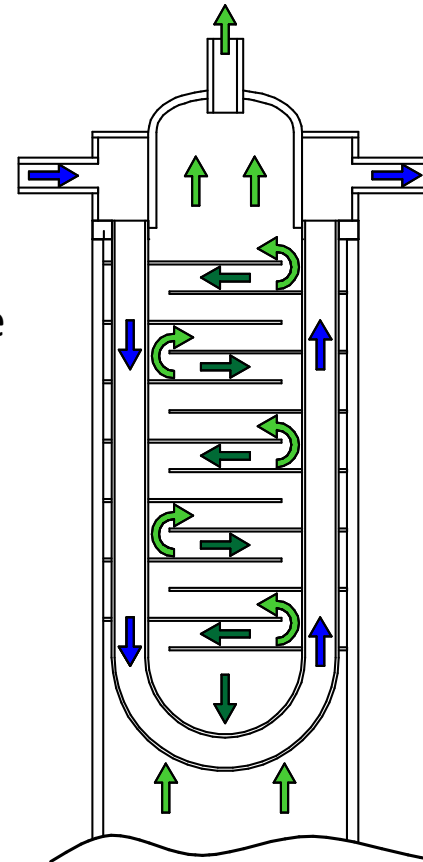

- Vapour flow
- Condensate reflux
- Water flow

Solution branch

The temperature at the base of the generator can be optimized controlling the poor solution mass flow rate

Refrigerant branch

The inlet refrigerant temperature of the evaporator is controlled by the expansion valve.

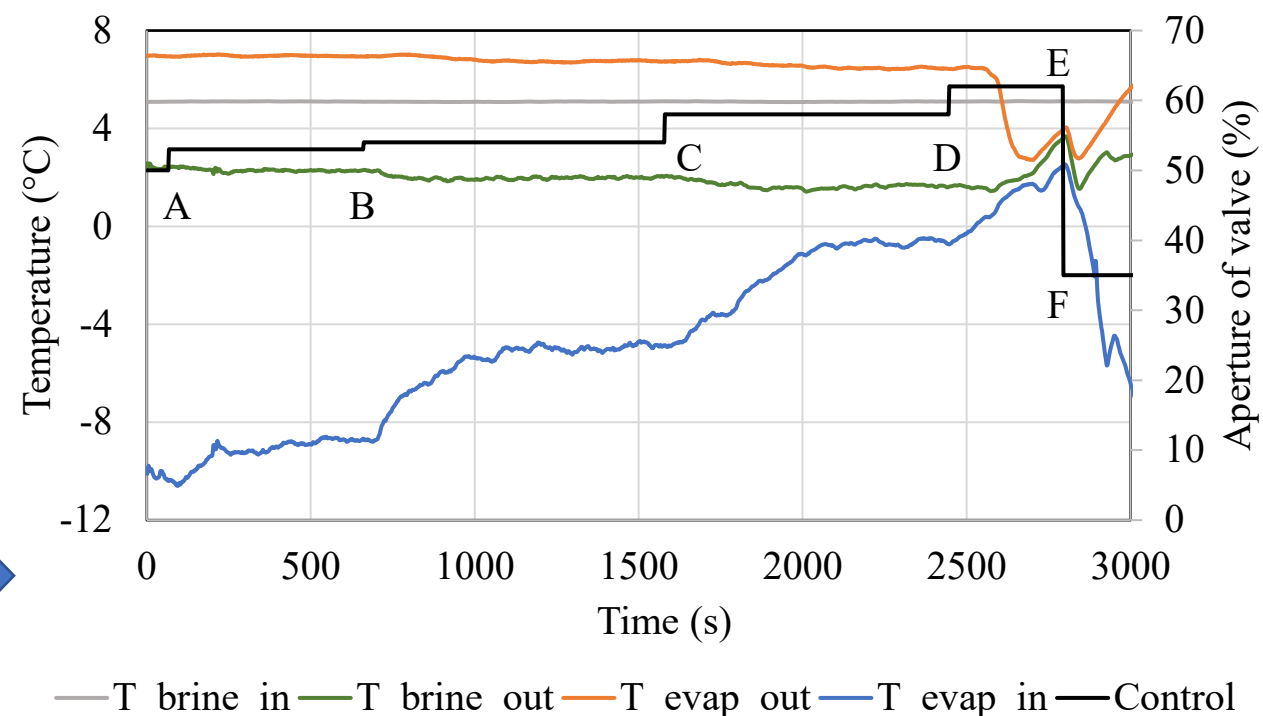



Full load performances



Full load performances (10 kW) with different supply water temperatures and air temperatures.

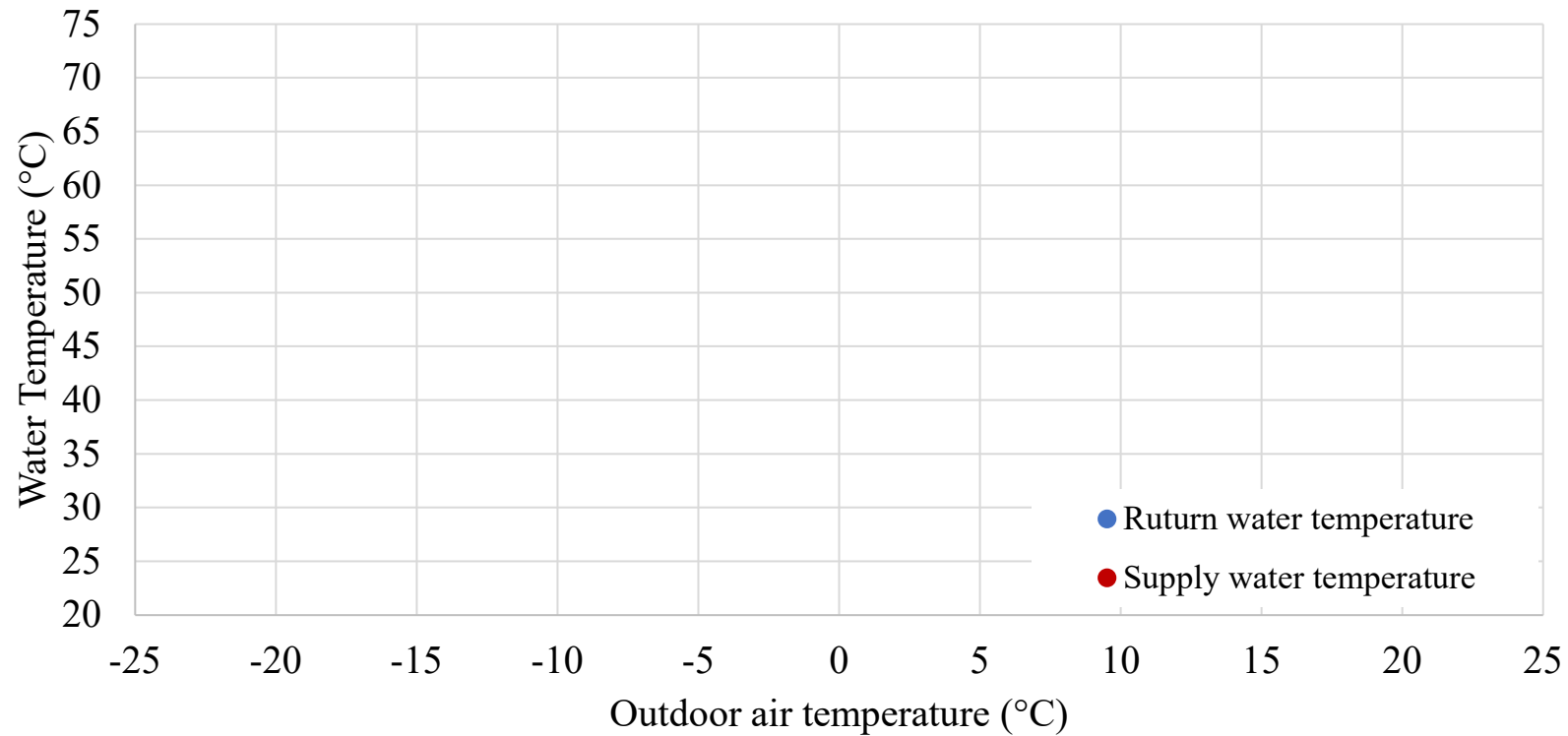

$$GUE = Q_h / Q_{\text{gas LHV}}$$

Full load performances (10 kW) with different supply water temperatures and air temperatures.

Radiator heating system in cold climate

Underfloor heating system in cold climate

Design condition for low-T application in the cold climate.

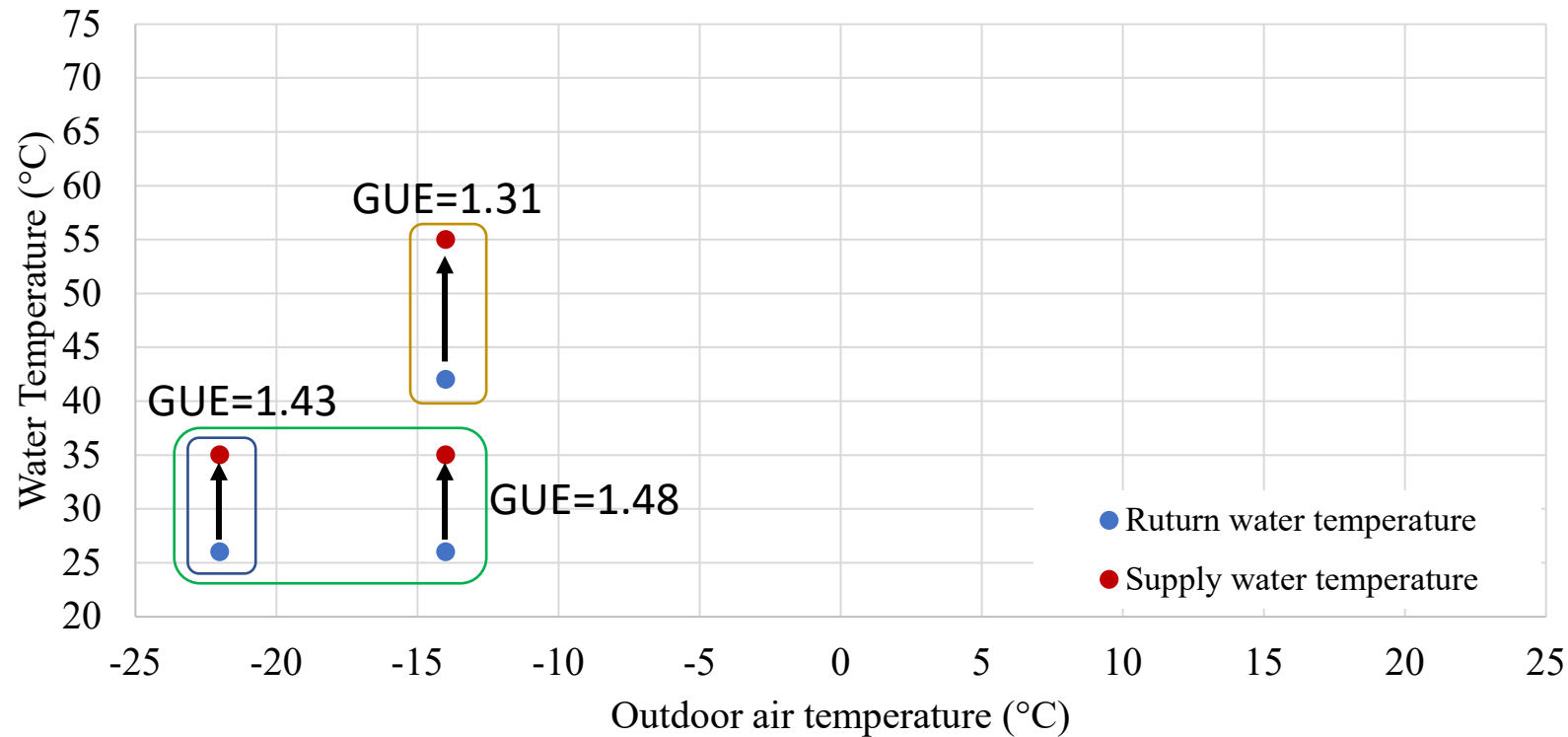

$$GUE = Q_h / Q_{\text{gas LHV}}$$



Full load performances



Full load performances (10 kW) with different supply water temperatures and air temperatures.

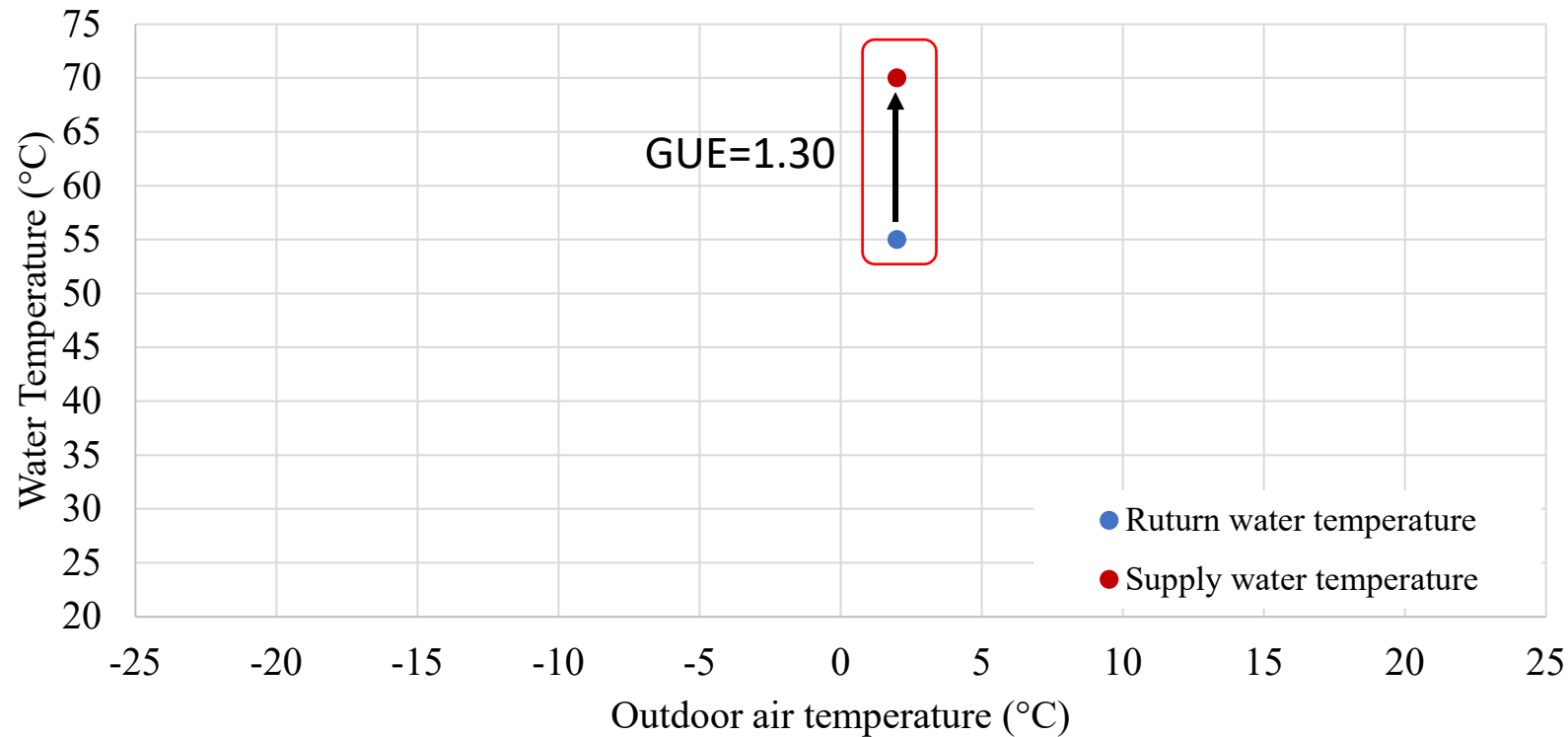

Realistic application
in old building with
radiators

$$GUE = Q_h / Q_{\text{gas LHV}}$$

Full load performances (10 kW) with different supply water temperatures and air temperatures.

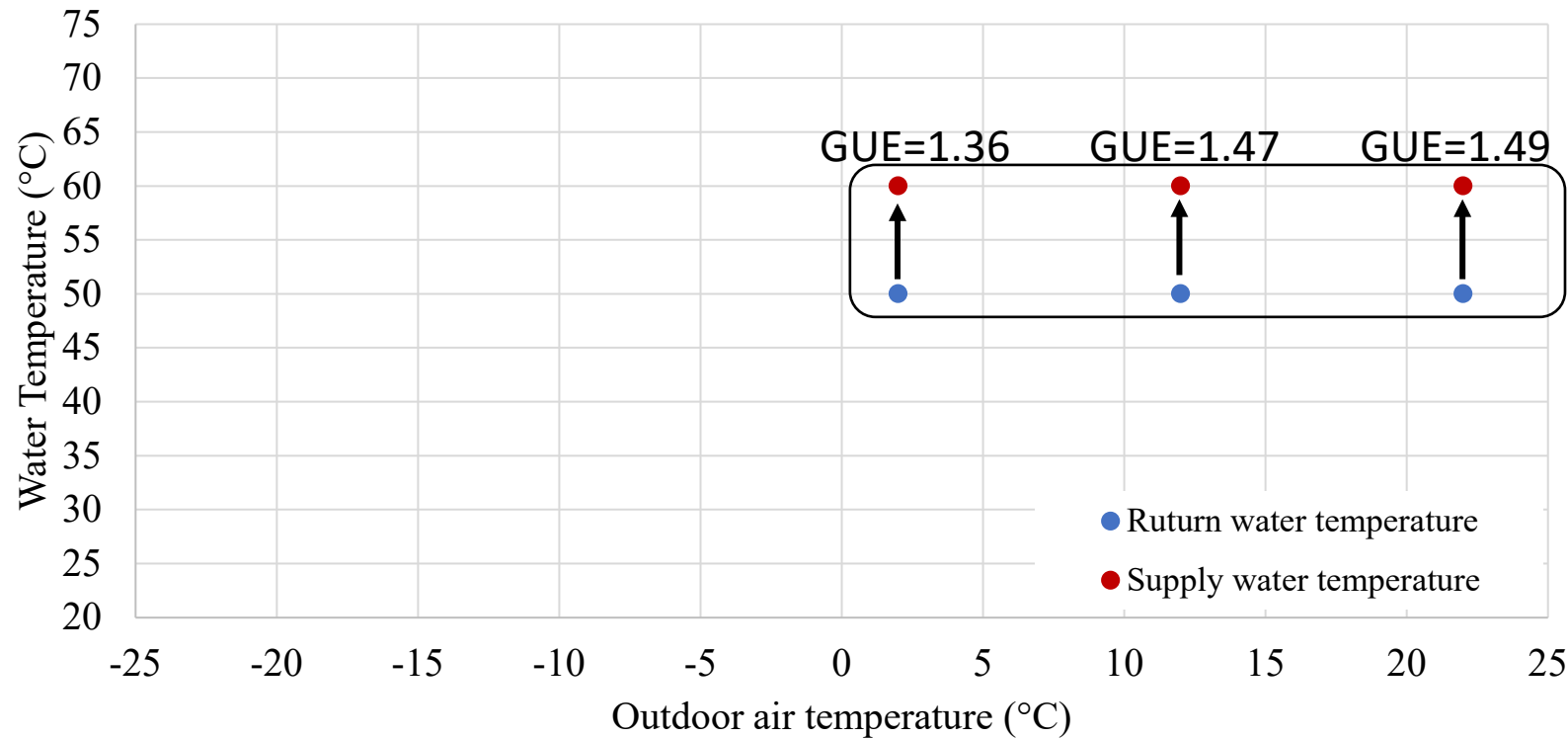

Domestic hot water production

$$GUE = Q_h / Q_{\text{gas LHV}}$$

Full load performances (10 kW) with different supply water temperatures and air temperatures.

Radiator heating system in cold climate

Underfloor heating system in cold climate

Design condition for low-T application in the cold climate.

$$GUE = Q_h / Q_{\text{gas LHV}}$$

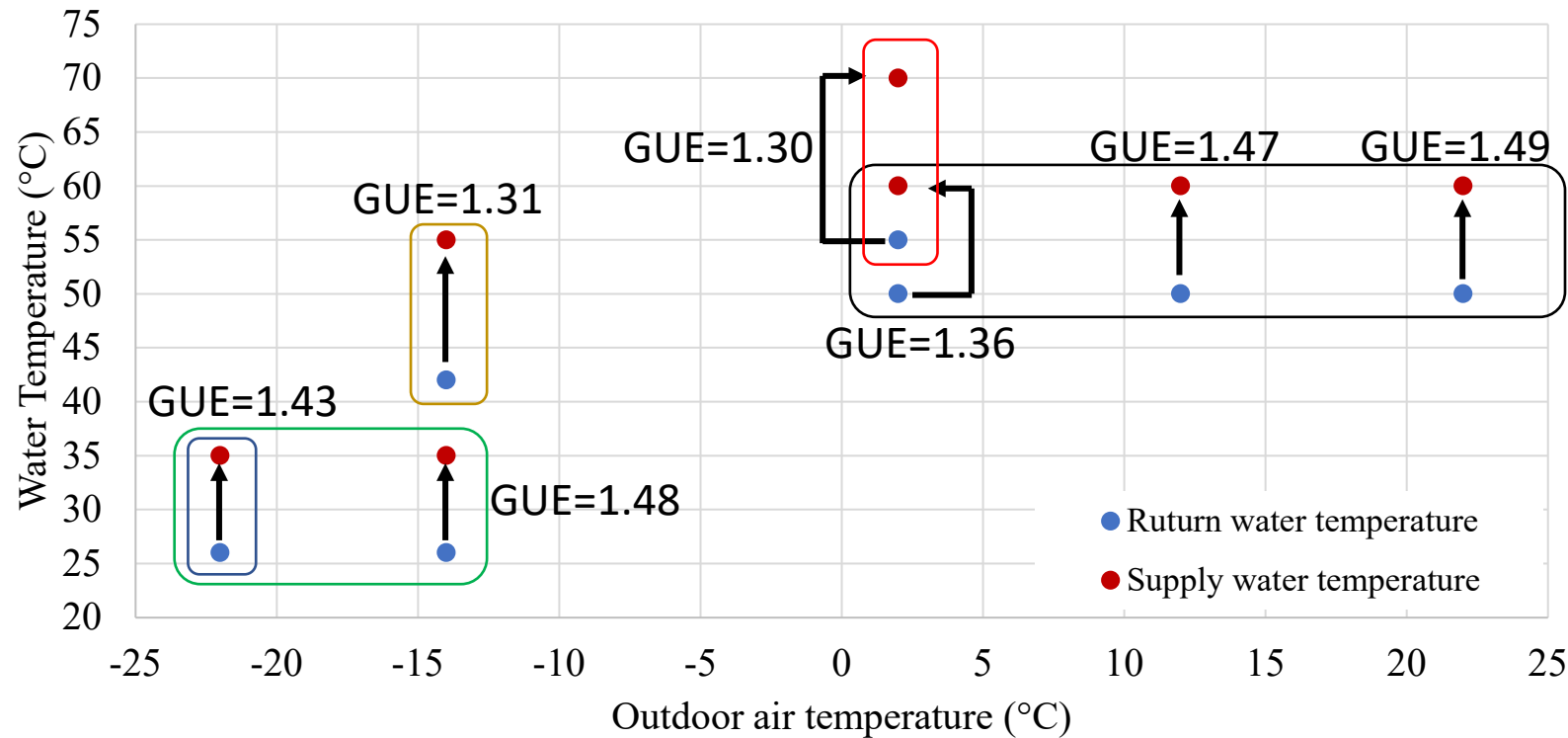

Realistic application in old building with radiators

Domestic hot water production

Rating conditions

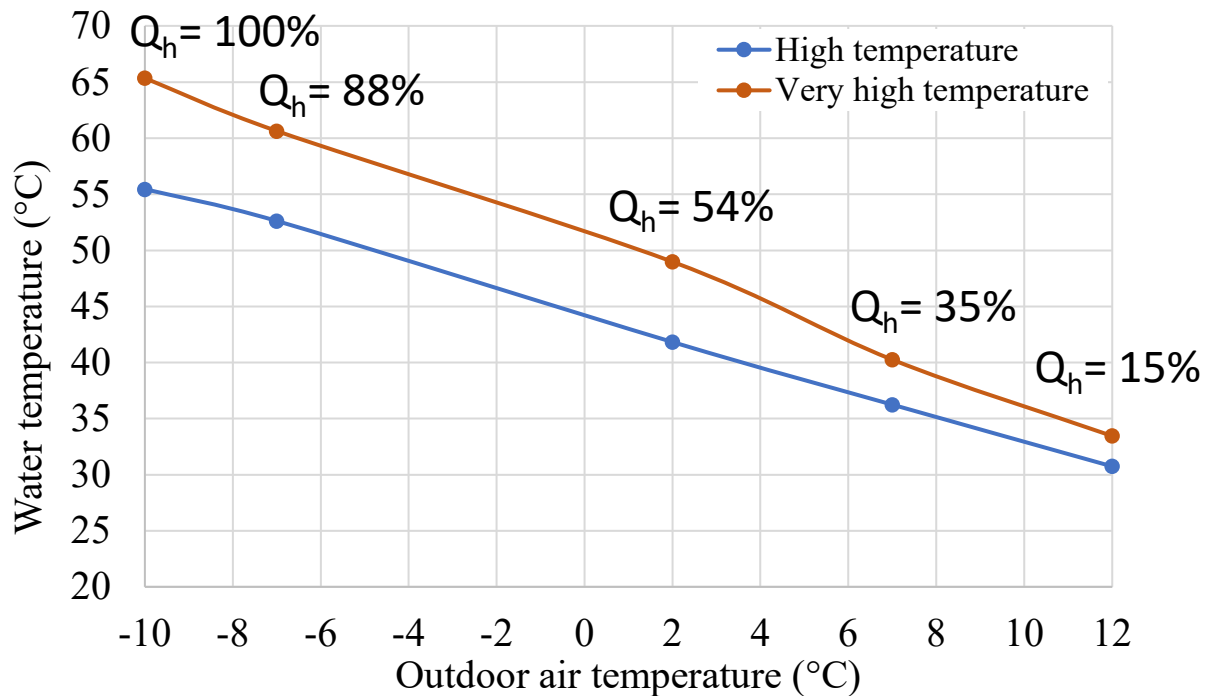

Performances

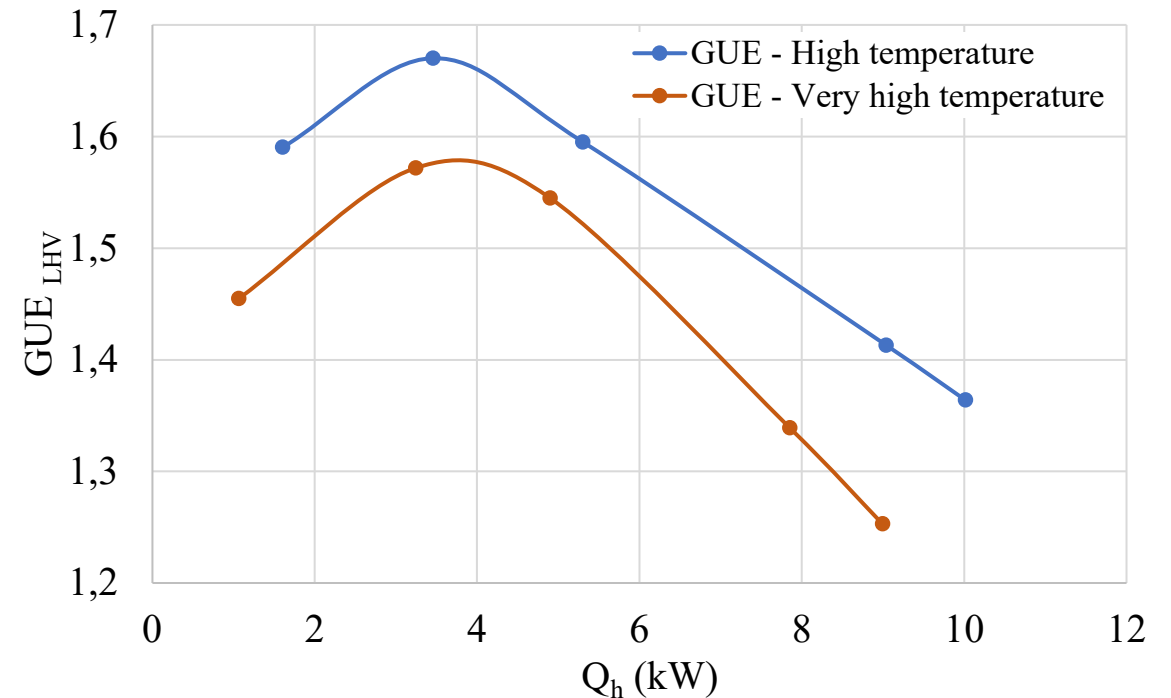

The resulting seasonal performances (SGUE) are **1.58** on net calorific value basis (1.42 on GCV) for the high temperature climatic curve and 1.50 for the very high temperature climatic curve (1.35 on GCV)

A **10 kW** gas driven absorption heat pump for residential application has been developed obtaining the following results:

1. Compact sealed circuit: **dimensions** (L=380 x W=380 x H=830 mm), without the outdoor heat exchanger
2. Regular plate heat exchangers proved to work efficiently in an absorption cycle.
3. Innovative patented generator and rectifier design
4. Variable solution flow control
5. Seasonal Gas Utilization Efficiency: **1.58** on net calorific value (1.42 on gross calorific value) for a high temperature climatic curve (radiators) and an average climate



Thank you