



Annex 54

Heat Pump Systems with Low-GWP Refrigerants

Country Report Italy

Author/s:

Sergio Bobbo, Stefano Bortolin,
Davide Del Col, Laura Fedele, Luca
Molinaroli, Giulio Onorati, Luigi
Sorabella

November 2024

Report no. HPT-AN54-4

Published by Heat Pump Centre

c/o RISE – Research Institutes of Sweden
Box 857, SE-501 15 Borås
Sweden
Phone +46 10 16 53 42

Website

<https://heatpumpingtechnologies.org>

Legal Notice

Neither the Heat Pump Centre nor any person acting on its behalf:

(a) makes any warranty or representation, express or implied, with respect to the information contained in this report; or
(b) assumes liabilities with respect to the use of, or damages, resulting from, the use of this information.

Reference herein to any specific commercial product, process, or service by trade name, trademark, manufacturer, or otherwise, does not necessarily constitute or imply its endorsement recommendation or favouring.

The views and opinions of authors expressed herein do not necessarily state or reflect those of the Heat Pump Centre, or any of its employees. The information herein is presented in the authors' own words.

© Heat Pump Centre

All rights reserved. No part of this publication may be reproduced, stored in a retrieval system, or transmitted in any form or by any means, electronic, mechanical, photocopying, recording or otherwise, without prior permission of the Heat Pump Centre, Borås, Sweden.

Production

Heat Pump Centre, Borås, Sweden

DOI: <https://doi.org/10.23697/xckb-y106>

Report No. HPT-AN54-4

Preface

This project was carried out within the Technology Collaboration Programme on Heat Pumping Technologies (HPT TCP), which is a Technology Collaboration Programme within the International Energy Agency, IEA.

The IEA

The IEA was established in 1974 within the framework of the Organization for Economic Cooperation and Development (OECD) to implement an International Energy Programme. A basic aim of the IEA is to foster cooperation among the IEA participating countries to increase energy security through energy conservation, development of alternative energy sources, new energy technology and research and development (R&D). This is achieved, in part, through a programme of energy technology and R&D collaboration, currently within the framework of nearly 40 Technology Collaboration Programmes.

The Technology Collaboration Programme on Heat Pumping Technologies (HPT TCP)

The Technology Collaboration Programme on Heat Pumping Technologies (HPT TCP) forms the legal basis for the implementing agreement for a programme of research, development, demonstration and promotion of heat pumping technologies. Signatories of the TCP are either governments or organizations designated by their respective governments to conduct programmes in the field of energy conservation.

Under the TCP, collaborative tasks, or "Annexes", in the field of heat pumps are undertaken. These tasks are conducted on a cost-sharing and/or task-sharing basis by the participating countries. An Annex is in general coordinated by one country which acts as the Operating Agent (manager). Annexes have specific topics and work plans and operate for a specified period, usually several years. The objectives vary from information exchange to the development and implementation of technology. This report presents the results of one Annex.

The Programme is governed by an Executive Committee, which monitors existing projects and identifies new areas where collaborative effort may be beneficial.

Disclaimer

The HPT TCP is part of a network of autonomous collaborative partnerships focused on a wide range of energy technologies known as Technology Collaboration Programmes or TCPs. The TCPs are organised under the auspices of the International Energy Agency (IEA), but the TCPs are functionally and legally autonomous. Views, findings and publications of the HPT TCP do not necessarily represent the views or policies of the IEA Secretariat or its individual member countries.

The Heat Pump Centre

A central role within the HPT TCP is played by the Heat Pump Centre (HPC).

Consistent with the overall objective of the HPT TCP, the HPC seeks to accelerate the implementation of heat pump technologies and thereby optimise the use of energy resources for the benefit of the environment. This is achieved by offering a worldwide information service to support all those who can play a part in the implementation of heat pumping technology including researchers, engineers, manufacturers, installers, equipment users, and energy policy makers in utilities, government offices and other organisations. Activities of the HPC include the production of a Magazine with an additional newsletter 3 times per year, the HPT TCP webpage, the organization of workshops, an inquiry service and a promotion programme. The HPC also publishes selected results from other Annexes, and this publication is one result of this activity.

For further information about the Technology Collaboration Programme on Heat Pumping Technologies (HPT TCP) and for inquiries on heat pump issues in general contact the Heat Pump Centre at the following address:

Heat Pump Centre

c/o RISE - Research Institutes of Sweden

Box 857, SE-501 15 BORÅS, Sweden

Phone: +46 10 516 53 42

Website: <https://heatpumpingtechnologies.org>



Executive summary

This report summarizes the activities carried out in Italy regarding the use of low-GWP refrigerants in heat pumping systems.

In Europe, a quest for environmentally friendly refrigerants began around 20 years ago because of the introduction of EU Regulation No. 40/2006 and 517/2014 on fluorinated greenhouse gases and the Kigali amendment to the Montreal protocol. The recent release of the updated version of F-Gas regulation (EU Regulation 573/2024) has introduced a clear direction towards the use of ultra-low GWP refrigerants, in some applications, set a threshold value for GWP equal to 150. Consequently, many ongoing research and development activities deal with this topic.

The Italian research team consists of 3 different research institutes (National Research Council, Polytechnic of Milano, University of Padova) actively involved in numerous research projects about low-GWP refrigerants complementary to each other. The research activities span from fundamental studies, which typically focus on components, to applied studies, which are usually carried out at the system level, and may be listed as follows:

- Assessment of refrigerant thermophysical properties.
- Assessment of performance during flow boiling and/or condensation, namely heat transfer coefficient and pressure drop.
- Assessment of energy performance, namely heating capacity and COP, in drop-in application in the laboratory environment.
- Energy and environmental analysis of traditional and innovative heat pump configurations that rely on low-GWP refrigerants, either with pilot plant monitoring or yearly simulation.

The main findings of the full set of research activities may be summarized as follows:

- Within the ongoing EU ECHO project, low-GWP refrigerants will be considered as a viable alternative to standard refrigerants to be used as working fluids in a single-stage heat pump integrated with an innovative thermal storage system.
- There is a tendency to progressively reduce the diameter of channels used in heat exchangers with the goal of lowering the refrigerant charge inside heat pumps. To assess and develop condensation and flow boiling heat transfer correlations, wide databases must be collected encompassing conditions that include pure fluids, mixtures, and small diameter channels. Heat transfer coefficients have been measured inside 1 mm and 3.4 mm diameter channels with binary mixtures composed of HFOs (hydrofluoroolefins) and HFCs (hydrofluorocarbon). Flow boiling experiments have been performed with ternary mixtures R455A and R452B.
- R32 and R290 are the most viable options for small-medium capacity heat pumps. Their use typically leads to energy performance that is similar, or even better, than that achieved with the “old”, standard refrigerant for this application, i.e. high-GWP R410A. From the environmental perspective, simulation results revealed that using



the two above-mentioned alternative refrigerants is beneficial as the TEWI reduces with respect to baseline systems.

- The same refrigerants are considered for the replacement of R134a in heat pump water heaters with the same, abovementioned advantages. From the safety concern point-of-view, it is proved that heat pump water heaters can be manufactured with a charge below the maximum allowable threshold value set by standards (i.e., 152 g for R290 and 1842 g for R32).
- For medium-large capacity heat pumps, which are typically operated with R134a, there are many low-GWP refrigerants that can be used as alternatives. Broad-range drop-in tests in the lab facility revealed that R513A is the refrigerant that provides the most similar heating capacity while leading to some penalization in terms of COP, whereas R1234ze(E) is the refrigerant that shows the most similar COP but suffers from the largest capacity reduction. All-in-all, R513A seems a good option in medium capacity heat pumps with a positive displacement compressor, while R1234ze(E) seems the preferred choice in medium to large systems manufactured with centrifugal compressors.
- The real performance of two geothermal heat pumps working alternative refrigerants has been measured in a pilot facility within the concluded EU GEO4CIVHIC project. In particular, R454B, a mixture of synthetic refrigerants (R32 and R1234yf) and isobutane (R600a, hydrocarbon), proved to be efficient for medium-temperature residential heat pumps. These two refrigerants had been chosen based on computer simulations on a wider range of boundary conditions, resulting in the best COP values among mid-term, R454B, and long-term, R600a, refrigerants.
- The use of natural fluids, such as CO₂, is increasingly growing. A dual-source transcritical CO₂ heat pump that uses hybrid photovoltaic-thermal (PV-T) collectors as evaporators has been studied. The heat pump works in different modes using air or solar radiation as thermal sources.
- The combined use of air and ground as heat sources can be a strategy to improve the efficiency of heat pumps at lower costs because the length of the borehole heat exchangers can be reduced. A heat pump prototype working with R32 has been investigated.



3.1 Research and Development Activities on Low-GWP Refrigerants in 2019

Prepared by

Sergio Bobbo¹, Stefano Bortolin², Davide Del Col², Laura Fedele², Luca Molinaroli^{3*}, Giulio Onorati⁴, Luigi Sorabella⁴

¹National Research Council, Construction Technologies Institute Corso Stati Uniti 4, 35127, Padova, Italy

²University of Padua, Department of Industrial Engineering Via Venezia 1, 35131, Padova, Italy

³Polytechnic of Milan, Department of Energy Engineering Via Raffaele Lambruschini 4/A, 20156, Milano (MI), Italy

⁴Daikin Applied Europe
Via Piani di Santa Maria 72, 00072, Ariccia (RM), Italy

* Corresponding Author, luca.molinaroli@polimi.it

This report briefly summarizes the ongoing activities carried out in Italy about the use of low global warming potential (GWP) refrigerants in heat pumps.

A broad range of research and development activities are carried out in Italy by both the research institutes and the companies. Indeed, since the introduction of the EU Regulation No. 40/2006 and 517/2014 on fluorinated greenhouse gases and of the Kigali amendment to the Montreal Protocol, the need to find low-GWP alternatives to traditional high-GWP ones has arisen.

This is particularly true in Italy, where the market share of vapor compression heat pumps has been expanding in the last few years (EHPA, 2018). Consequently, research institutes, universities, and companies started research programs aimed at studying the low-GWP refrigerants most comprehensively. As a result, research activities that deal with the measurement of the thermophysical properties, the characterization of the component's behavior (namely, heat exchangers and compressors), and the overall system performance have been active since 2011.

Although a wide range of refrigerants is considered, a definite low-GWP refrigerant that could replace traditional, high-GWP refrigerant in small, medium, or high-capacity systems has not been found yet, making this kind of analysis even more important.

3.1.1 Introduction

In recent years, the air-conditioning and heat pump industries have been strongly affected by national and international regulations on environmental protection and global warming. Most of the fluids currently used (e.g., R410A and R134a) are hydrofluorocarbons (HFCs) that display a high



value of global warming potential (GWP), and they will be substituted in the next years. The search for alternatives to high-GWP refrigerants is focused primarily on using natural fluids (hydrocarbons, ammonia, carbon dioxide) and new synthetic refrigerants with low-GWP.

In this context, at the country level, the research groups in research institutes or academia and research and development groups in companies are carrying out a wide range of activities related to using the fourth generation of refrigerant in vapor compression systems.

Generally speaking, ongoing studies can be divided into two groups: component-level and system-level studies.

At the component level, measurements of the thermophysical properties of low-GWP refrigerants, heat transfer characteristics, and compressor behavior are carried out. These fundamental researches are essential for providing reliable data for the correct sizing of heat pumps working with low-GWP refrigerants.

At the system level, drop-in analyses or testing of new systems specifically designed for low-GWP refrigerants are carried out. These studies are important since they provide data for refrigerant comparison and tuning heat pump models for LCA analyses.

More details about each of the above-mentioned activities are provided in the following sections.

3.1.2 Activities on low-GWP refrigerants' thermophysical properties

The selection of the most suitable working fluids for refrigeration, heat pumping, and organic Rankine cycle applications to meet the necessity to limit and control the emissions of greenhouse substances established by the Kyoto Protocol (UNFCCC (1997)) and, more specifically, the EU Regulation No. 517/2014 on fluorinated greenhouse gases, is based on a number of criteria, including environmental considerations (low-GWP, zero or near-zero ODP), safety (low toxicity, low flammability), and performance (high efficiency, appropriate capacity). Other important criteria, such as cost, material compatibility, and lubricant solubility/miscibility, should also be considered for commercialization.

The most systematic and complete analyses conducted to date of working fluids capable of satisfying the above-mentioned criteria for a few applications have been undertaken by McLinden et al. (2014) and McLinden et al. (2015). For low- and medium-temperature HVAC&R applications, including obviously heat pumps, they limited their focus to a group of sixty-two potentially attractive working fluids, with the largest number being HFOs. HFOs are particularly important in cases where natural fluids such as CO₂, NH₃, or hydrocarbons (HCs) are not applicable due to their thermodynamic limitations, flammability, or toxicity.

However, the availability of thermodynamic data for such fluids, essential to develop accurate Equations of State (EoS) and then to predict and evaluate their performance in actual machines, is still quite poor, except for some of the available fluids, as highlighted by a thorough and wide-ranging search of the publicly available literature published in a recent paper (Bobbo et al., 2018). The analysis allowed us to determine and evaluate the experimentally determined data for some important thermodynamic and transport properties of several HFO and HCFO working fluids, both pure and mixed with other H(C)FOs or HFCs. Table 3-1 lists the actual number of papers in 2017 for each pure HFO refrigerant reporting experimental data. Even if the data were not updated, it is reasonable to assume that the table still represents the present situation. The most investigated fluids are R1234yf and R1234ze(E), followed by R1234ze(Z) and R1233zd(E). Many fewer references are available for most fluids, and for some of them, no references at all were found.



It is worth noting that identifying long-term low-GWP solutions for substituting the current refrigerants in heat pump applications cannot be achieved considering pure compounds only. Mixtures HFOs/HFOs or HFOs/HFCs offer an important opportunity to tune the properties of the refrigerants in applications where the properties of the available pure compounds are not satisfying. However, the data available in the literature for mixtures are even poorer than for pure HFOs, and thus, a systematic experimental activity is required to develop suitable EoS also for these fluids.

Table 3-1 Number of peer-reviewed literature references reporting experimental data/estimations for important thermophysical properties of several HFO and HCFO refrigerants (N.B. the same paper can report data for different properties).

ASHRAE	Thermodynamic Properties					Transport Properties		
Designation	CP	P_{sat}	PVT	c_p	ω	λ	μ or ν	σ
R1123	2	2	2					
R1141								
R1132(E)								
R1234yf	2	11	10	5	4	1	7	2
R1243zf	1	2	1					1
R1234ye(E)								
R1234ze(E)	2	13	14	6	4	2	4	3
R1225ye(Z)		1	1					
R1132(Z)								
R1225ye(E)								
R1234ze(Z)	1	8	7		1	1	2	1
R1233zd(E)	1	4	5	1	2		1	2
R1336mzz(E)	1	1	1					
R1336mzz(Z)	1	4	1		1			
R1354mzy(E)	1	1	3					
R1354myf(E)			1					

3.1.2.1 Activities at ITC-CNR

The main part of the activities of ITC-CNR on Low-GWP refrigerants is devoted to measuring some thermodynamic properties to evaluate the efficiency analysis of hydrofluoroolefins (HFOs). At present, only pure compounds have been studied, but research activities on mixture properties are scheduled for the near future. The thermodynamic properties measured at ITC-CNR are the following:

Saturation pressure measurements are obtained by means of a static vapor–liquid equilibrium (VLE) apparatus in the temperature range between 243.15 K and 343.15 K and pressures up to 3500 kPa. Typical uncertainties for these measurements are ± 1 kPa in pressure and ± 0.03 K in temperature.

Vapor-Liquid Equilibria (VLE) measurements for binary mixtures are obtained by means of the same static apparatus coupled with a gas-chromatograph to measure, after proper calibration and phase recirculation to ensure equilibrium achievement, the composition of vapor and liquid phase at equilibrium. For each isotherm, all the range of compositions between the pure compounds is



explored by measuring around 10 points. The measurement temperature range is between 243.15 K and 343.15 K, with pressures up to 3500 kPa. Typical uncertainties for these measurements are ± 1 kPa in pressure, ± 0.03 K in temperature, and $< \pm 0.003$ in mass fraction for the composition.

Compressed liquid density measurements are obtained using a stainless-steel vibrating tube density meter (Anton Paar DMA 512) in the temperature range between 253.14 K and 343.15 K and pressures up to 35 MPa. Typical uncertainties for these measurements are $< \pm 1$ kg m⁻³ in density, ± 20 kPa in pressure, and ± 0.03 K in temperature.

Refrigerant-oil solubility measurements are performed using a setup based on the synthetic method in isothermal conditions. For each isotherm, the range of compositions between the pure compounds (refrigerant and oil) is explored by measuring around 10 points. These measurements can describe mutual solubility and miscibility gaps. The measurement temperature range is between 243.15 K and 343.15 K, with pressures up to 10 MPa. Typical uncertainties for these measurements are ± 20 kPa in pressure, ± 0.03 K in temperature, and $< \pm 0.003$ in mass fraction for the composition.

Regarding HFO refrigerants, several measurements have been performed in the last few years for saturated pressure and compressed liquid. The fluids studied are the following:

1. R1234yf. Data in Fedele et al. (2011) and in Fedele et al. (2012).
2. R1234ze(E). Data in Brown et al. (2012) and in Di Nicola et al. (2012).
3. R1243zf. Data in Brown et al. (2013) and in Di Nicola et al. (2013).
4. R1234ze(Z). Data in Fedele et al. (2014a) and in Fedele et al. (2014a).
5. R1225ye(Z). Data in Brown et al. (2015) and in Fedele et al. (2016).
6. R1233zd(E). Data in Di Nicola et al. (2017) and in Fedele et al. (2018).

In the next future, the fluids R1224yd(Z) and R1336mzz(E) will be studied.

3.1.3 Activities on heat transfer of low-GWP refrigerants

Most synthetic refrigerants that have been proposed in the last few years as low-GWP alternatives to traditional refrigerants are substances that, if on one side, have positive environmental characteristics, on the other side, have some inherent drawbacks such as flammability. One possible solution to limit the hazard that arises from their use is the shifting from single components to blends of refrigerants (e.g., mixing HFCs and hydrofluoroolefins) to satisfy the demand for a wide range of working conditions, tuning the thermophysical properties reducing or eliminating, the flammability issue. Experimental works carried out to investigate condensation and flow boiling characteristics of non-azeotropic mixtures of HFCs and HFOs (hydrofluoroolefins) are limited in the literature, especially when moving to small-diameter channels. In convective heat transfer applications, flow passages sizes are shifting towards smaller dimensions to enhance the heat transfer coefficient and to reduce the charge of the working fluid inside the heat exchanger, limiting the risks connected to the release of potentially hazardous fluids in the atmosphere. To increase the performance of heat exchangers and to realize a correct design, it is essential to have predictive tools suitable also for the new refrigerants. In two-phase flow, CFD simulations are still too time expensive and empirical or semi-empirical correlations remain, for the moment, the most reliable methods. However, this approach requires, from one side, many experimental data and, from the other side, correlations that are able to describe the main physics of the phenomena.



3.1.3.1 Activities at University of Padua

The research activity on low-GWP refrigerants at the Department of Industrial Engineering is focused on the characterization of their thermal performance and in the development of new correlations for heat exchanger design. Both natural and synthetic fluids (pure and mixtures) have been investigated.

Considering natural fluids, Del Col et al. (2017) studied condensation heat transfer, flow boiling heat transfer and two-phase pressure drop of propylene (R1270) flowing inside a 0.96 mm diameter channel. A comparative analysis of the condensation performance of R1270, R290, and two HFCs was made with the objective of minimizing the exergy losses. An estimation of the condenser refrigerant charge was also performed.

Considering synthetic fluids, heat transfer coefficients have been measured with pure olefins (such as R1234yf and R1234ze(E)) and with R32 now, which represents a substitute for R410A. For instance, Del Col et al. (2015) investigated condensation of R1234ze(E) at 40°C saturation temperature in a single circular microchannel with a 0.96 mm internal diameter. Rossato et al. (2017) presented an innovative aluminum heat exchanger composed of rectangular channels (1.8 mm hydraulic diameter), and they measured the local heat transfer coefficient inside this compact device during condensation and vaporization of R32. Concerning the use of R32, the Department of Industrial Engineering has also been involved in the GEOTECH Horizon 2020 project, working on the modeling and test of a reversible dual source (ground and air) heat pump working with refrigerant R32 (Zanetti et al., 2018).

Recently, research activity has also focused on non-azeotropic mixtures. Azzolin et al. (2016) measured flow boiling heat transfer coefficients inside a 0.96 mm microchannel with a mixture R1234ze(E)/R32 at 0.5/0.5 mass composition. The refrigerant mixture displays lower heat transfer coefficients than those of the pure fluids. In a recent paper, Azzolin et al. (2019) investigated the condensation heat transfer coefficient of zeotropic mixtures R455A and R452B inside a 0.96 mm diameter mini channel and inside an 8.0 mm diameter channel.

Test rigs available at DII. Two experimental test rigs are available at the Two-Phase Heat Transfer Laboratory of the Department of Industrial Engineering for the study of heat transfer during condensation and flow boiling inside channels. One experimental apparatus is designed for conventional channels (i.e., 8 mm internal diameter), while the other test rig allows the measurement of heat transfer coefficients inside small diameter channels (from 3 mm down to 1 mm). The two facilities can be equipped with different test sections, and they present a similar layout consisting of a primary refrigerant loop and several auxiliary water loops. In the primary loop, the subcooled refrigerant is sent by a magnetic-driven gear pump to a heat exchanger, and then it enters the test section where condensation or evaporation takes place using water as a secondary fluid. After the test section, the refrigerant enters the post-condenser, where it is fully condensed and subcooled. This configuration allows us to make measurements without the presence of oil in the circuit, and, at the same time, an easy replacement of the refrigerant is possible.

In the case of the 8 mm diameter test section, the heat transfer coefficient is obtained by measuring the heat flow rate exchanged (from the water side), the refrigerant saturation temperatures at the inlet and outlet of the test section, and the wall temperatures at the inlet and outlet of the heat transfer sector (by means of thermocouples embedded in the tube wall).

In the case of the 1 mm channel, the test section has been designed to allow precise measurements of the water temperature profile (by means of several thermocouples), which is, in turn, used for the determination of local heat flux and, hence, of the local heat transfer coefficient.



Annex 54, Heat pump systems with low-GWP refrigerants

Coriolis-effect mass flow meters are employed for both the refrigerant and the hot water loops. In the water circuits, thermocouples and thermopiles are used to measure the water inlet temperatures and the temperature differences. Wall temperatures are directly measured along the test section by thermocouples embedded in the tube wall.

Planned activity for the next two years. The availability of reliable tools for heat exchanger design is very important for the project of heat pumps operating with new low-GWP fluids. In some cases, new refrigerants are non-azeotropic mixtures, and thus, during phase change at constant pressure, they present a temperature glide that can be as high as 10 K or even higher. Such temperature variation during phase change could lead to better matching between the refrigerant and the water temperature profiles in a condenser, thus reducing the exergy losses associated with the heat transfer process. Nevertheless, the additional mass transfer resistance that occurs during the phase change of zeotropic mixtures leads to heat transfer degradation. Therefore, the design of a condenser or an evaporator working with a zeotropic mixture poses the problem of how to extend the correlations developed for pure fluids to the case of mixtures. Experimental data are very helpful in the assessment of design procedures.

For this reason, the planned activity for the next two years will focus on measuring the heat transfer coefficients during condensation and flow boiling inside smooth channels. Two-channel diameters will be considered: 1 mm and 8 mm. Regarding the selected mixtures, both binary and ternary blends will be considered. Binary and ternary mixtures available in the market will be investigated. Initially, R455A, which is a blend of R1234yf, R32, and CO₂ (75.5/21.5/3.0 by mass composition), and R452B, which is composed of R32, R1234yf, and R125 (67.0/26.0/7.0 by mass composition) are going to be tested. These two mixtures of HFCs and HFOs display low-GWP_{100-years} Value and are non-azeotrope, with a temperature glide of about 10 K for R455A and 1 K for R452B. The effect of vapor quality, heat flux, mass velocity, mass composition, and channel diameter on the heat transfer coefficient will be investigated. New experimental data on the heat transfer coefficient obtained during convective condensation and flow boiling will be compared with those of the pure components (i.e., R1234yf and R32). This allows us to analyze the heat transfer penalization due to the zeotrope of the mixture. The collected database will be used to assess predictive correlations for condensation and flow boiling of mixtures, providing valuable information on the applicability of models.

Besides those blends, fluids among those available in the market will be tested during condensation and flow boiling.

3.1.4 Activities on compressor using low-GWP refrigerants

From the compressor point of view, an activity related to the development and qualification of compressors working with low-GWP refrigerants is ongoing at the national level. Indeed, in these years the Italian compressor manufacturers are developing, testing, and commercializing new models of compressors specifically designed to account for the thermophysical properties of the low-GWP refrigerants. The compressors that are designed are semi-hermetic reciprocating and screw ones. It is worth mentioning that this is usually done under the ASERCOM performance certification program.

3.1.4.1 Activities at Polytechnic of Milan

At the laboratory of the Polytechnic of Milan, an experimental campaign devoted to the measurement of the performance of a semi-hermetic, variable speed reciprocating compressor working with R134a and its low-GWP alternatives (R1234yf, R1234ze(E), R450A and R513A) is



on-going with the aim of measuring the most important parameters: sucked mass flow rate, power consumption, discharge temperature and volumetric and isentropic efficiencies.

The goal of the analysis is to characterize the compressor performance in a large range of operating conditions, i.e. low to mid evaporating temperature and mid to high condensing temperature, with particular emphasis on the comparison among baseline and alternative refrigerants. This analysis would provide data from complete or enlarged databases currently available (Mota-Babiloni et al., 2014 and Mendoza-Miranda et al., 2016) about the performance of this kind of compressor when working with low-GWP refrigerants. Moreover, starting from previous experience (Dardenne et al., 2015, Molinaroli et al., 2017), a semi-empirical modeling activity of this kind of compressor is performed with particular attention to the fluid change (Byrne et al., 2014).

3.1.4.2 Activities at Daikin Applied Europe

At Daikin Applied Europe, extensive research activity is related to screw and centrifugal compressors. These compressors are used in large-capacity systems, where R134a is the preferred refrigerant. Among the different alternatives, R1234ze(E) seems to be the most viable in these systems, and therefore, it is further analyzed.

In comparison with R134a, R1234ze(E) has slightly lower saturated pressure, approximately 25% lower cooling capacity, and the same (or slightly higher) efficiency. Drop- in in existing units designed for R134a is possible with minor modification; just the loss of capacity is expected.

Air-cooled and water-cooled chillers with inverter-driven screw compressors have been designed by Daikin Applied and are already in production, mainly as a drop-in of R1234ze(E) in R134a units. The study of units (chillers and heat pumps) optimized for R1234ze(E) is in progress; three main areas need to be investigated:

- Compressor optimization for R1234ze(E). The reduced cooling capacity of this refrigerant (at the same swept volume) makes compressor cost approximately 25% higher. The use of Variable Frequency Drive (VFD) and optimized compressor geometry can reduce this gap.
- Units refrigerant charge. R1234ze(E) cost is still higher than that of R134a. So, it is required to reduce units' refrigerant charge. Being most of the refrigerant charge in heat exchangers, enhancement in heat exchangers is required.
- Extend units (mainly heat pumps) operating range. The lower condensing pressure of R1234ze(E) compared with R134a (at the same temperature) allows for increasing the condensing temperature without increasing design stress. This would allow us to increase the operating range of heat pumps, making them comparable with boilers. On the other hand, heat pumps require evaporation at negative temperatures where R1234ze(E) pays a penalty with respect to R134a, either in terms of capacity or efficiency. An increase in discharge temperature must be evaluated in terms of material stability (refrigerant polymerization, oil viscosity, differential thermal expansion, etc.) and component life (bearings, valves, etc.)

Moreover, R1234ze(E) is a low flammable refrigerant according to ISO 817/2014 (where flammability is evaluated at 60°C) while it is not flammable according to CLP regulation 1272/2008 (where flammability is evaluated at 20°C). As a matter of fact, R1234ze(E) shows flame propagation above 28 °C; this makes it not well accepted in indoor installations with high refrigerant amounts, like high-capacity centrifugal chillers/heat pumps.

For this kind of installation, R1233zd(E) is selected. This refrigerant is a low pressure, non-flammable refrigerant and has the big advantage of making simpler the mechanical design of pressure vessels. On the other side, the totally different characteristics with respect to R134a (high specific volume and higher-p force user ratio) force us to completely redesign the centrifugal



compressor from the aerodynamic point of view. Also, heat exchangers need to be redesigned, making the heat exchanger design a second field of investigation.

3.1.5 Activities on heat pump

At the heat pump level, activities related to the experimental or numerical characterization of the use of low-GWP refrigerant as alternatives to traditional R410A and R134a are ongoing. In this field, the open literature is quite rich in experimental studies (see, e.g. Ortega et al., 2019, Qiu et al., 2019 Sánchez et al., 2017, Schultz, 2019) but there is not any definite answer to the problem of refrigerant substitution and, therefore, a lot of room for research and development activities arises.

3.1.5.1 Activities at ITC-CNR

In the last years, ITC-CNR has been involved in two Horizon2020 EU projects dedicated to the development of ground source heat pumps (GSHPs) in all of Europe. In particular, within the GEO4CIVHIC project, CNR-ITC is involved in a specific activity aimed at identifying low-GWP refrigerants as substitutes for R134a (low-pressure refrigerants) and R410A (high-pressure refrigerants). The selection is performed on the base of software developed in the MATLAB® environment to simulate the behavior of the studied refrigerants in thermodynamic cycles (basic or regenerative) in the range of operative conditions for reversible GSHP in Europe. The software is coupled with the REFPROP 10.0 database to calculate the thermodynamic properties of the refrigerants at each characteristic point of the cycles. The software allows a full energetic and exergetic analysis of the cycles to give as much information as possible on the thermodynamic behavior of the refrigerants to properly address the most suitable for the given operative conditions.

3.1.5.2 Activities at Polytechnic of Milan

At the Polytechnic of Milan, an experimental set-up that mimics a water-to-water heat pump is available for studying refrigerant alternatives. The test rig basically consists of three different loops: the refrigerant loop, the cold water + ethylene glycol loop (evaporator loop) and the hot water loop (condenser loop) and is fully instrumented to measure the main operating parameters such as pressures, temperatures, flow rates and power.

The test rig is used to carry out experimental study of refrigerant alternatives in a drop-in application and allows reaching temperature in the range 263.15 K – 293.15 K in the cold water + ethylene glycol loop and in the range 303.15 K – 353.15 K in the hot water loop. An experimental campaign considering R134a as baseline refrigerant and R1234yf and R1234ze(E) as low-GWP alternatives was carried out and the analysis of the use of R450A and R513A is planned for the near future.

3.1.5.3 Activities at Daikin Applied Europe

Daikin company is working on low-GWP refrigerants since 2014 introducing R32 (GWP 675) as a substitute of R410A (GWP 2088) In household equipment; Daikin company owned 93 patents covering R32 use in HVAC equipment and in 2015 he offered worldwide free access to all basic patents.

As a consequence of the owned basic knowledge on R32 the same choice has been made for low-end, low-spec, applied products: Air-cooled chiller with scroll compressors up to 700 kW cooling capacity. Design and test of air to water heat pumps with scroll compressors and R32, in the same capacity range, is in progress.

R32 was considered not to be suitable for high capacity or high specifications products because: (i) due to GWP=675, R32 is not a long-term solution; next steps in F- gas phase down will, for sure,



Annex 54, Heat pump systems with low-GWP refrigerants

affect R32 price in future; (ii) pressure and temperatures in R32 thermodynamic cycle, together with safety classification (PED group 1 fluid) make complex to design high capacity units and (iii) flammability characteristics of R32 make it not well accepted is high quantity onsite.

Consequently, for high-capacity specifications applied products two different choices were made:

1. R1234ze(E) for air-cooled and water-cooled chillers using screw compressors.
2. R1233zd(E) for water-cooled chillers using centrifugal compressors.

Both refrigerants may be considered long-term solutions having single digit GWP (R1234ze(E) = 7 and R1233zd(E) = 4.5) with a projection for further reduction of R1234ze(E) GWP < 1 according to the last IPCC report.

Additionally, most of the existing installations in HVAC use HFC and, in particular, R410A in low-capacity installation and R134a in high-capacity installation.

Customers start to be afraid about the future availability of HFC refrigerants, as well as about their cost, and start to ask for retrofit solutions for existing units with low-GWP refrigerants; on the new installation, customers even prefer traditional HFC solutions (mainly due to cost) ask for an assurance of future possibility to retrofit with low-GWP refrigerants.

Retrofit refrigerant must have, of course, reduced GWP compared with existing ones and, in addition, must show similar performances (cooling capacity, power input) and be compatible with the material used in today's solutions.

Retrofit candidates are mostly a blend of HFC and HFO, like R513A. Consequently, the following areas need to be investigated: (i) retrofit solution for scroll with R410A, (ii) retrofit solution for screw with R134a, and (iii) retrofit solution for centrifugal with R134a.

The investigation must account for performance, material compatibility and regulation impact first.

3.1.5.4 Overall activities in Italy

Overall, in Italy, all the manufacturers of vapor compression heat pumps are involved in in-house research activities to test, develop, and commercialize heat pumps working with low-GWP refrigerants. R32 is the working fluid considered in small-medium capacity systems, whereas R1234ze(E) and R513A are the refrigerants used in medium-large capacity systems. Some commercial products are already available on the market.

Finally, some manufacturers produce and commercialize heat pumps working with natural refrigerants such as R290 or R744.

3.1.6 Conclusions

Overall, at the national level, a wide range of research and development activities are carried out on low-GWP refrigerants by both the research institutes and the manufacturers.

At the component level, the study of the fourth generation of refrigerants begins with a very basic analysis, such as the measurement of the thermophysical properties, and then moves to the measurement of the component's performance, namely the performance of heat exchangers and compressors.

At the system level, both fundamental studies, i.e., simulation or drop-in analyses, and applied studies, i.e., development and commercialization of heat pumps that use low-GWP refrigerants, are going to be performed.



To sum up, many research and development activities are ongoing at the country level about low-GWP refrigerants. However, it is not yet possible to find some final alternative to traditional, high GWP refrigerant. As a result, the current activities not only have to go on in the next years, but, if possible, to be strengthened.

3.1.7 Nomenclature

CP	critical point
P_{sat}	saturation pressure (kPa)
PVT	Pressure-Volume-Temperature
C_p	isobaric heat capacity ($J \cdot kg^{-1} \cdot K^{-1}$)
ω	acentric factor (-)
λ	thermal conductivity ($W \cdot m^{-1} \cdot K^{-1}$)
μ	dynamic viscosity ($Pa \cdot s$)
ν	kinetic viscosity ($m^2 \cdot s^{-1}$)
σ	surface tension ($N \cdot m^{-1}$)

3.1.8 Acknowledgment

The support of the Italian Ministry for Education and Research (MIUR) through the project PRIN 2015 (Grant Number 2015M8S2PA) is acknowledged.

3.1.9 Reference

- Azzolin, M., Berto, A., Bortolin, S., Moro, L., Del Col, D., 2019. Condensation of ternary low-GWP zeotropic mixtures inside channels. *Int. J. Refrig.*, 103, 77-90.
- Azzolin, M., Bortolin, S., Del Col, D., 2016. Flow boiling heat transfer of a zeotropic binary mixture of new refrigerants inside a single microchannel. *Int. J. Therm. Sci.*, 110, 83-95.
- Bobbo, S., Di Nicola, G., Zilio, C., Brown, S. and Fedele, L., 2018. Low-GWP halocarbon refrigerants: A review of thermophysical properties, *Int. J. Refrig.*, 90, 181-201.
- Brown, J.S., Di Nicola, G., Zilio, C., Fedele, L., Bobbo, S. and Polonara, F., 2012. Subcooled Liquid Density Measurements and PvT Measurements in the Vapor Phase for trans- 1,3,3,3-Tetrafluoroprop-1-ene (R1234ze(E)). *J. Chem. Eng. Data*, 57, 3710–3720.
- Brown, J.S., Di Nicola, G., Fedele, L., Bobbo, S. and Zilio, C., 2013. Saturated pressure measurements of 3,3,3-Trifluoroprop-1-ene (R1243zf) for reduced temperatures ranging from 0.62 to 0.98. *Fluid Phase Equilib.* 351, 48-52.
- Brown, J.S., Fedele, L., Di Nicola, G., Bobbo, S. and Coccia, G., 2015. Compressed Liquid Density and Vapor Phase PvT Measurements of cis-1,2,3,3,3-Pentafluoroprop-1-ene (R1225ye(Z)). *J. Chem. Eng. Data*, 60, 3333–3340.
- Byrne, P., Ghouali, R. and Miriel, J., 2014. Scroll compressor modelling for heat pumps using hydrocarbons as refrigerants. *Int. J. Refrig.*, 41, 1-13.



Annex 54, Heat pump systems with low-GWP refrigerants

- Dardenne, L., Fraccari, E., Maggioni, A., Molinaroli, L., Proserpio, L. and Winandy, E., 2015. Semi-empirical modelling of a variable speed scroll compressor with vapour injection. *Int. J. Refrig.*, 54, 76–87.
- Del Col, D., Bortolato, M., Azzolin, M., Bortolin, S., 2015. Condensation heat transfer and two-phase frictional pressure drop in a single minichannel with R1234ze(E) and other refrigerants. *Int. J. Refrig.*, 50, 87-103.
- Del Col, D., Azzolin, M., Bortolin, S., Berto, A, 2017. Experimental results and design procedures for minichannel condensers and evaporators using propylene. *Int. J. Refrig.*, 83, 23-38.
- Di Nicola, G., Brown, J.S., Fedele, L., Bobbo, S. and Zilio, C., 2012. Saturated Pressure Measurements of trans-1,3,3,3-Tetrafluoroprop-1-ene (R1234ze(E)) for Reduced Temperatures Ranging from 0.58 to 0.92. *J. Chem. Eng. Data*, 57, 2197-2202.
- Di Nicola, G., Brown, J.S., Fedele, L., Securo, M., Bobbo, S. and Zilio, C., 2013. Subcooled liquid density measurements and PvT measurements in the vapor phase for 3,3,3- trifluoroprop-1-ene (R1243zf). *Int. J. Refrig.*, 36, 2209-2215.
- Di Nicola, G., Fedele, L., Brown, J.S., Bobbo, S. and Coccia, G., 2017. Saturated Pressure Measurements of trans-1-Chloro-3,3,3-trifluoroprop-1-ene (R1233zd(E)), *J. Chem. Eng. Data*, 57, 2197-2202.
- EU May 17th, 2006. Directive (EU) No. 40/2006 of the European Parliament and of the Council relating to emissions from air-conditioning systems in motor vehicles and amending Council Directive 70/156/EEC.
- EU April 16th, 2014. Regulation (EU) No. 517/2014 of the European Parliament and of the Council on fluorinated greenhouse gases and repealing Regulation (EC) No 842/2006.
- European Heat Pump Association (EHPA), European Heat Pump Market and Statistics – Report 2018.
- Fedele, L., Bobbo, S., Groppo, F., Brown, J. S. and Zilio, C., 2011. Saturated Pressure Measurements of 2,3,3,3-Tetrafluoroprop-1-ene (R1234yf) for Reduced Temperatures Ranging from 0.67 to 0.93. *J. Chem. Eng. Data*, 56, 2608–2612.
- Fedele, L., Brown, J. S., Colla, L., Ferron, A., Bobbo, S. and Zilio, C., 2012. Compressed Liquid Density Measurements for 2,3,3,3-Tetrafluoroprop-1-ene (R1234yf). *J. Chem. Eng. Data*, 57, 482–489.
- Fedele, L., Di Nicola, G., Brown, J.S., Bobbo, S. and Zilio, C., 2014a. Measurements and Correlations of cis-1,3,3,3-Tetrafluoroprop-1-ene (R1234ze(Z)) Saturation Pressure. *Int. J. Thermophys.* 35 1-12.
- Fedele, L., Brown, J.S., Di Nicola, G., Bobbo, S and Scattolini, M., 2014b. Measurements and Correlations of cis-1,3,3,3-Tetrafluoroprop-1-ene (R1234ze(Z)) Subcooled Liquid Density and Vapor-Phase PvT. *Int. J. Thermophys.*, 35, 8, 1415-1434.
- Fedele, L., Di Nicola, G., Brown, J.S., Colla, L. and Bobbo, S., 2016. Saturated pressure measurements of cis-Pentafluoroprop-1-ene (R1225ye(Z)). *Int. J. Refrig.*, 69, 243-250.
- Fedele, L., Pierantozzi, M., Di Nicola, G., Brown, J.S. and Bobbo, S., 2018. Compressed Liquid Density and Vapor Phase PvT Measurements of trans-1-Chloro-3,3,3-trifluoroprop-1-ene [R1233zd(E)]. *J. Chem. Eng. Data*, 63, 225–232.



Annex 54, Heat pump systems with low-GWP refrigerants

- McLinden, M.O., A.F. Kazakov, J.S. Brown and Domanski, P., 2014. A thermodynamic analysis of refrigerants: Possibilities and tradeoffs for Low-GWP refrigerants. *Int. J. Refrig.*, 38, 80–92.
- McLinden, M.O., A.F. Kazakov, J.S. Brown and Domanski, P., 2015. Hitting the bounds of chemistry: limits and tradeoffs for low-GWP refrigerants. *Proc. 24th IIR International Congress of Refrigeration (ICR2015) 16 – 22 August 2015, Yokohama, Japan.*
- Mendoza-Miranda, J.M., Mota-Babiloni, A., Ramírez-Minguela, J.J., Muñoz-Carpio, V.D., Carrera-Rodríguez, M., Navarro-Esbrí, J. and Salazar-Hernández, C., 2016. Comparative evaluation of R1234yf, R1234ze(E) and R450A as alternatives to R134a in a variable speed reciprocating compressor. *Energy*, 114, 753-766.
- Molinaroli, L., Joppolo, C.M. and De Antonellis, S., 2017. A semi-empirical model for hermetic rolling piston compressors. *Int. J. Refrig.*, 79, 226–237.
- Mota-Babiloni, A., Navarro-Esbrí, J., Barragán, Á, Molés, F. and Peris, B., 2014. Drop-in energy performance evaluation of R1234yf and R1234ze(E) in a vapor compression system as R134a replacements. *Appl. Therm. Eng.* 71, 259-265.
- Ortega, I., Sieres, J., Cerdeira, F., Álvarez, E. and Dopazo, J.A., 2019. Experimental study of R454B drop-in performance in a R410A liquid-to-water heat pump. *Proc. 25th IIR International Congress of Refrigeration (ICR2019) 24 – 30 August 2019, Montreal, Canada, 1726-1733.*
- Qiu, J., Zhang, H., Sheng, J. and Wu, Z., 2019. Experimental investigation of L41b as replacement for R410A in a residential air-source heat pump water heater. *Energ Buildings*, 199, 190-196.
- Rossato, M., Da Silva, J.D., Ribatski, G., Del Col, D., 2017. Heat transfer and pressure drop during condensation of low-GWP refrigerants inside bar-and-plate heat exchangers. *Int. J. Heat Mass Transf.*, 114, 363-379.
- Sánchez, D., Cabello, R., Llopis, R., Arauzo, I., Catalán-Gil, J. And Torrella, E., 2017. Energy performance evaluation of R1234yf, R1234ze(E), R600a, R290 and R152a as low-GWP R134a alternatives. *Int. J. Refrig.*, 74, 269–282.
- Schultz, K., 2019. Review of next generation low GEP refrigerants for chiller products. *Proc. 25th IIR International Congress of Refrigeration (ICR2019) 24 – 30 August 2019, Montreal, Canada, 633-640.*
- Zanetti, E., Azzolin, M., Bortolin, S., Busato, G., Del Col, D., 2018. Design and testing of a microchannel heat exchanger working as condenser and evaporator. *Proceedings of the 17th International Refrigeration and Air Conditioning Conference at Purdue.*



3.2 Research and Development Activities on Low-GWP Refrigerants in 2020

Prepared by:

Sergio Bobbo¹, Stefano Bortolin², Davide Del Col², Laura Fedele¹, Luca Molinaroli^{3*}, Giulio Onorati⁴, Luigi Sorabella⁴

**¹National Research Council, Construction Technologies Institute
Corso Stati Uniti 4, 35127, Padova, Italy**

**²University of Padua, Department of Industrial Engineering
Via Venezia 1, 35131, Padova, Italy**

**³Polytechnic of Milan, Department of Energy Engineering
Via Raffaele Lambruschini 4/A, 20156, Milano (MI), Italy**

**⁴Daikin Applied Europe
Via Piani di Santa Maria 72, 00072, Ariccia (RM), Italy**

*** Corresponding Author, luca.molinaroli@polimi.it**

This report briefly summarizes the activities carried out during the 2nd year of Annex 54 in Italy.

Due to the COVID-19 emergency, research activities slightly slowed down both at research institutes and company levels. Despite this, advances in using low-GWP refrigerants in heat pumps have been made, as detailed in the following sections. It should be noted that since the Italian team consists of four different research groups, the document is organized into four sections, one for each research group.

3.2.1 Activities at Daikin Applied Europe

Daikin has been working on low-GWP refrigerants since 2014, introducing R32 (GWP 675) as a substitute for R410A (GWP 2,088) in household equipment. Daikin owned 93 patents covering R32 use in HVAC equipment, and in 2015, he offered worldwide free access to all basic patents.

Due to the owned basic knowledge on R32, the same choice has been made for low-end, low specification, applied products: air-cooled chiller with scroll compressors up to 700 kW cooling capacity.



In 2018, the cooling only R32 air-cooled chiller was launched in the market in the capacity range of 80 - 700 kW; air-to-water heat pump development started in 2019, and a relevant development was performed in 2020.

3.2.1.1 Research activities on R32 Air to Water heat pumps in 2020

As for many worldwide companies, Daikin's research activities in 2020 were strongly affected by the COVID-19 pandemic. In particular, several schedules were delayed because of local or national restrictions or lockdowns.

Nevertheless, many research activities were conducted, and relevant results were obtained. Two main research lines were conducted in 2020:

1. Air-to-refrigerant finned tube heat exchangers characterization.
2. Parallel operation of scroll compressors.

3.2.1.2 Air-to-refrigerant finned tube heat exchangers characterization

An air-to-refrigerant heat exchanger is one of the most critical components in an air-to-water heat pump; in fact, such a heat exchanger must work as an evaporator or a condenser. In addition, it must work in counter flow in one mode and parallel flow in the other.

Optimization of such components is a complex job, and compromise has to be accepted; the first compromise to be accepted is that advanced technologies today widely adopted in air-to-refrigerant condensers, like mini or microchannel coils, are not yet reliable in the evaporation mode, either on refrigerant-side and air-side heat transfer.

Consequently, copper tubes and aluminum fin coils were investigated either in evaporation or condensation mode, as well as in parallel and counterflow.

Results show better performances of coils when operating with R32 versus R410A in any condition, In particular:

- The R32 evaporating coil has 16% higher capacity in counterflow and 12% higher capacity in parallel flow with respect to R410A (Figure 3-1).
- The R32 condensing coil has almost the same capacity in counterflow while has 5% higher capacity in parallel flow with respect to R410A (Figure 3-2).
- The R32 evaporating coil loses 11% capacity from counterflow to parallel flow, while the condensing coil loses 23% capacity.

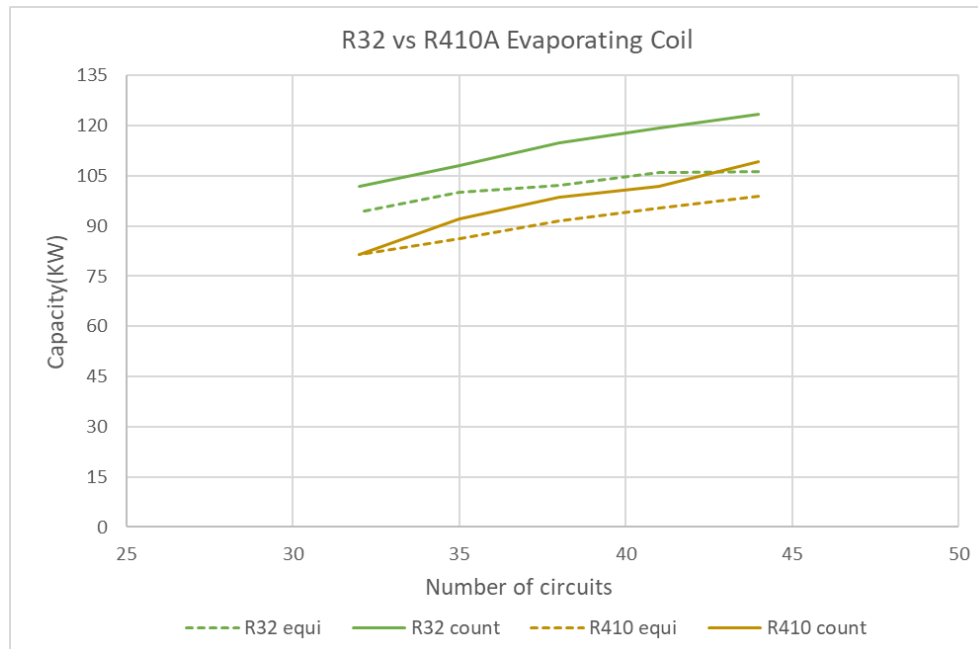

Figure 3-1: Evaporating coils test.

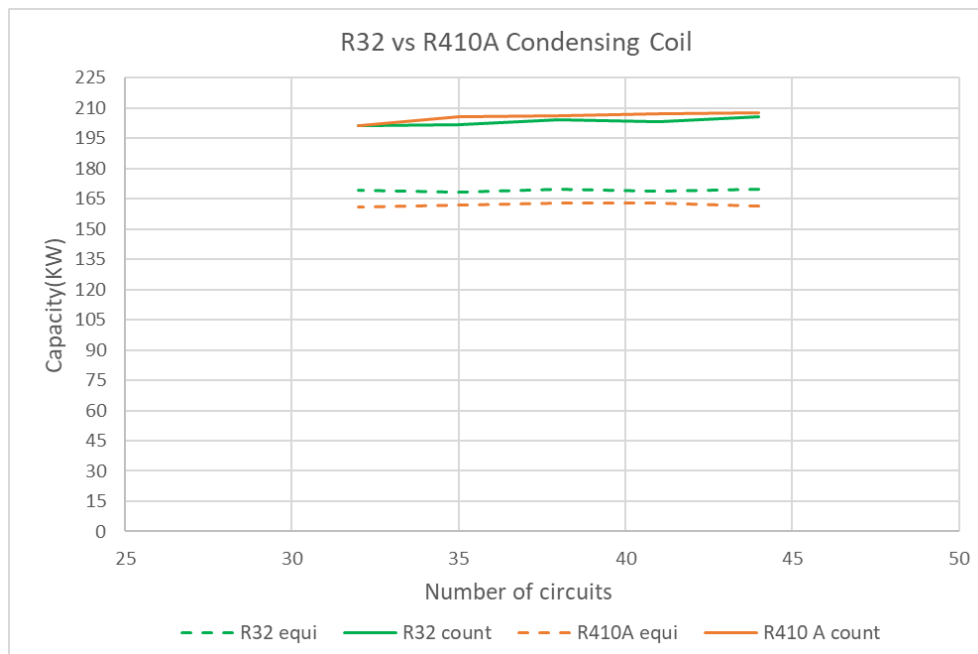

Figure 3-2: Condensing coils test.

A problem that had to be faced in evaporating coils is the distribution of two-phase flow among parallel circuits in the coil; bad distribution occurs when some circuit receives more liquid refrigerant than others. This creates a bad heat exchange since these circuits cannot evaporate all the liquid while other circuits mostly have vapor inside (Figure 3-3).

The solution has to be found by looking for the best “circuiting” of coil tubes; this means, for a given number of tubes, looking for the right number of tubes in series and parallel. On the other hand, it

is clear that a number of circuits in the coil is driven by the evaporating operation being the condensing operation is quite independent of this parameter.



Figure 3-3: Bad distribution example.

3.2.1.3 Parallel operation of scroll compressors

Given the size of scroll compressors, typical operation in heat pumps is with two (tandem) or three (trio) compressors in parallel (Figure 3-4).

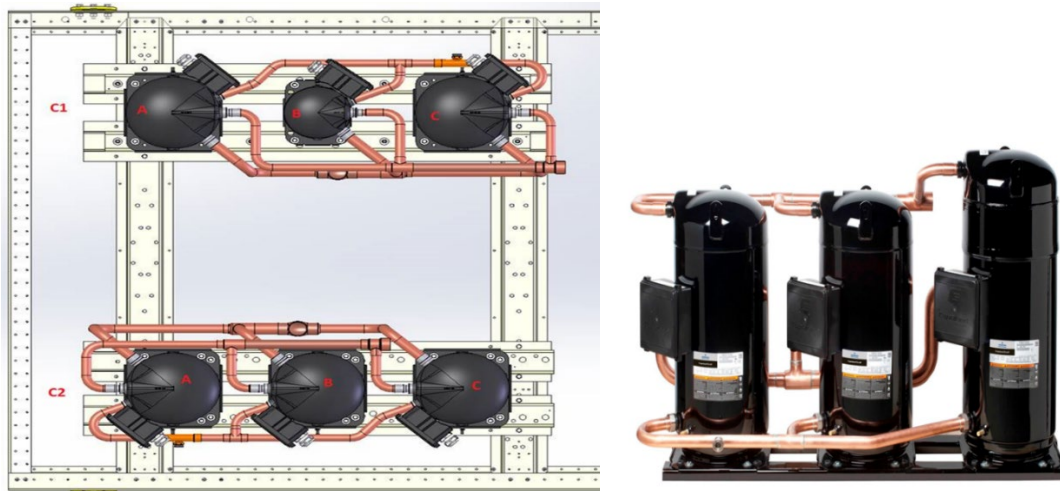

Figure 3-4: Scroll compressors in uneven trio.

When oiled compressors (compressors where oil is injected in the refrigerant flow) like scrolls work in parallel, one relevant problem is to ensure that oil leaving any compressor together with the refrigerant flow returns to the same compressor, otherwise, some compressors will suffer for oil lack while others are full of oil with risk of “solid suction”.

The problem, known as “oil balancing”, was already faced and solved for cooling-only applications, but heat pump application requires a significantly wider compressor envelope, and cooling-only



Annex 54, Heat pump systems with low-GWP refrigerants

solutions are not reliable enough. In particular, an operation with a very high pressure ratio is required when there is a cold environment and hot water has to be produced. Also, a low-pressure ratio is necessary in hot climates and medium-temperature water. The situation is even more complex at part load when some compressors are on and others off; the oil trend is to evacuate from stopped compressors to fill in the running ones.

Many test campaigns have been conducted to find the best configuration, especially for the trio, in particular, the following aspects were investigated:

- Compressor positions in uneven combination (position of smallest and largest compressor with respect to other compressors and refrigerant flow direction).
- Piping layout (refrigerant flow direction, straight portions, bends radius, etc.).
- Flow regulation devices (diaphragms) in the piping aimed to create the desiderate pressure distribution among compressors suction).

In addition, activities have been conducted on the compressor's sequencing logic to allow a correct operation rotation, preventing a compressor from staying too many times switched off or, for example, running alone.

3.2.2 Activities at the National Research Council

The emergency caused by COVID-19 has strongly influenced the activities performed during 2020. In particular, access to the laboratory was very limited: thus, experimental research was almost blocked. The main activities developed at ITC-CNR in the last year can be summarized as follows.

3.2.2.1 Activities within the Go4Civhic EU project on geothermal heat pumps

3.2.2.1.1 Refrigerant selection

The general purpose of the project is to introduce significant technical innovations and solutions for each component necessary to install and exploit geothermal systems for building retrofits: drilling machine and methodology, ground source heat exchanger design and materials, and compact and hybrid heat pumps for high and low-temperature terminals.

ITC-CNR is involved in the selection of new low-GWP refrigerants as medium- and long-term substitutes for the present high-GWP refrigerants used in the heat pumps (mainly R410A and R134a).

In the last year, new potential refrigerants have been included in the analysis and some new cycles have been considered. The following fluids have been considered at the moment as potential medium-term alternatives:

- Substitutes for R134a (low pressure): R513A, R1234yf, R1234ze(E), R515A, R515B, R516A, R1224yd(z), R1233zd(E).
- Substitutes for R410A (high pressure): R32, R452B, R454B.

Each fluid has been evaluated by simulating its performance in a series of heat pump cycles by means of a specific software developed in MATLAB environment, with the support of REFPROP 10.0 database to calculate the thermodynamic properties.

The cycles considered are the following:

- a) Basic cycle.
- b) Regenerative cycle.



- c) Cycle with economizer at the compressor.
- d) Cycle with economizer.
- e) Cycle with vapor-liquid separator and auxiliary compressor (not for zeotropic mixtures).

Boundary temperatures for the secondary fluids at the geothermal source and the user sink have been assumed according to the typical values for different European zones.

The main results obtained are the following:

- R516A is the most promising substitute for R134a.
- R454B is the most promising substitute for R410A.
- Cycles c) and e) are those giving the best COP.

3.2.2.1.2 Heat pump monitoring at the CNR demo site

A series of sites have been selected to install demonstrative geothermal heat pumps with the aim of experimentally evaluating the feasibility and effectiveness of the innovative solutions developed within the project. At the demo site of CNR in Padova, two heat pumps will be installed: one with on/off control and the other with variable control.

Each heat pump and the secondary fluids circuits will be equipped with a monitoring system to evaluate their energetic performance during at least one year of acquisitions. In the last year, the monitoring system has been designed, and the necessary components (temperature and pressure sensors, mass and volumetric flowrate measuring devices, acquisition system, software, etc.) have been purchased. The installation of sensors and acquisition systems is forecast for the beginning of next year. Immediately after, the heat pumps and the monitoring will be started.

3.2.2.2 Thermophysical properties of new refrigerants for heat pump applications

Measurements of the saturated pressure and compressed liquid density for the HFO R1224yd(Z) have been performed, mostly before the COVID-19 emergency.

31 saturation pressures have been measured by means of a static vapor-liquid equilibrium (VLE) apparatus in the range of temperatures between 293.15 to 353.15 K.

At the same time, 90 compressed density liquid data were obtained using a stainless steel vibrating tube density-meter (Anton Paar DMA 512) in the temperature range between 283 K and 363 K and pressures up to 35 MPa.

3.2.3 Activities at University of Padua

The research activity performed at the Department of Industrial Engineering (University of Padova) during 2020 has been focused on heat transfer measurements with low-GWP mixtures and on the experimental investigation of a solar-assisted heat pump working with CO₂.

3.2.3.1 Condensation and flow boiling of low-GWP non-azeotropic mixtures

Refrigerants currently employed in heat pumps and in air-conditioning systems (e.g. R410A) cannot be easily substituted with low-GWP pure fluids. Most of the proposed substitutes are binary or ternary mixtures (made of HFCs and HFOs): they usually include R32 and a halogenated olefin like R1234yf or R1234ze(E). In many cases, when the working fluid is going to be replaced, some of the components of the system must be modified and a new design for the heat exchangers must be considered. As a general trend, the diameter of pipes used in heat exchangers is going down. For example, in finned-tube coils heat exchangers, diameters around 5 mm are often employed. Minichannel heat exchangers (with internal diameter of around 1-2 mm) are a common solution for the automotive sector, and they are also used in air-cooled chillers. Therefore, it is important to

extend available databases encompassing conditions that include HFCs/HFOs mixtures and small diameter channels. This data can then be used for the assessment of heat transfer correlations for heat exchangers design.

At the University of Padova, heat transfer coefficients have been measured during condensation and flow boiling inside a 0.96 mm diameter channel (Figure 3-5). A binary mixture made of R32 and olefin R1234ze(E), 0.748/0.251 by mass composition, has been considered in the study. This blend has been selected because it presents a $GWP_{100\text{-years}}$ around 500 and it can be considered a possible substitute of R410A.

Condensation heat transfer coefficients have been measured at saturation pressure of 21.8 bar (corresponding to a dew point temperature of 41.5 °C) with mass flux ranging between $150 \text{ kg m}^{-2} \text{ s}^{-1}$ and $800 \text{ kg m}^{-2} \text{ s}^{-1}$. The condensation heat transfer coefficients for the blend are lower than the ones calculated with a linear interpolation from the values pertaining to the pure fluids (for mass velocity $G = 400 \text{ kg m}^{-2} \text{ s}^{-1}$, the penalization is equal to 10.1% at vapor quality equal to 0.6). The deviation from the ideal linear behavior can be explained by considering the mass transfer resistance. A comparison between the condensation performance of the blend and its pure fluids R32 and R1234ze(E) has been done considering exergy losses. In these conditions, the heat transfer coefficient of the 75/25% mixture is on average 32.8% lower than that of R32 and 91.9% higher than that of pure R1234ze(E).

Flow boiling tests have been run at 17 bar (corresponding to a bubble temperature of 28.7 °C), mass velocity between 300 and $600 \text{ kg m}^{-2} \text{ s}^{-1}$, and heat flux between 30 and 245 kW m^{-2} . Considering flow boiling tests, the heat transfer coefficient increases with the heat flux and to a less extend with mass velocity. The heat transfer coefficient decreases with the vapor quality for all the values of mass velocity. A degradation of about 30% of the heat transfer coefficient for the blend with respect to an ideal linear behavior from the values pertaining to the pure fluids has been observed. This penalization is due to the mass transfer resistance.

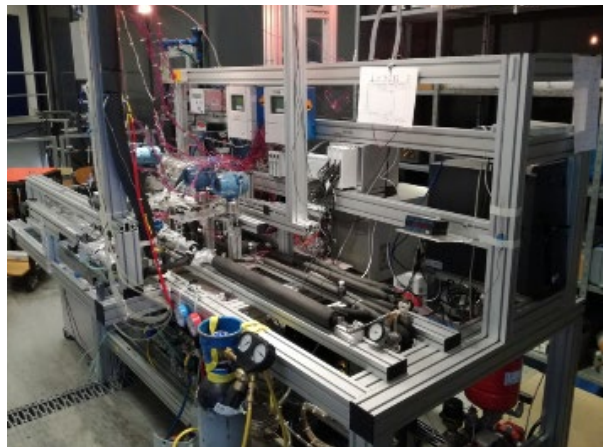

Figure 3-5: Experimental test rig for the measurement of the condensation and vaporization heat transfer coefficient inside minichannels.

Most of the studies available in the literature focus on flow boiling of binary mixtures of HFCs and HFOs, while works on multi-component blends are rare. Heat transfer coefficients were measured during the flow boiling of ternary non-azeotropic mixtures inside two horizontal smooth tubes with an inner diameter of 8.0 mm and 0.96 mm [2, 3]. The experimental tests are performed with



mixtures R455A (R32/R1234yf/R744 at 21.5/75.5/3% by mass) and R452B (R32/R1234yf/R125 at 67/26/7% by mass), displaying respectively a temperature glide of about 11 K and 1 K in the present tests. R452B and R455A can be considered as substitutes for R410A and R404A, respectively. The effects of vapor quality, saturation pressure, heat flux, mass velocity, and channel diameter on the heat transfer coefficient of the mixtures have been investigated.

At the same operating conditions, R452B displays higher flow boiling heat transfer coefficients than R455A. The reduced heat transfer performance in the case of R455A is due to fluid properties and the additional mass transfer resistance related to the temperature glide. In the case of the 8.0 mm diameter channel, the heat transfer coefficient of the two blends increases with heat flux, mass velocity, and vapor quality. In the 0.96 mm diameter channel, the R455A flow boiling heat transfer coefficient increases with the heat flux while it is less sensitive to mass velocity. The heat transfer coefficients in the 0.96 mm channel are higher than those measured in the 8.0 mm diameter channel in the low-quality region. Models developed for pure fluids, which generally overestimate the heat transfer performance of the blends and do not account for the penalization due to the mass diffusion effects, must be corrected to consider the additional mass transfer resistance.

3.2.3.2 Solar-assisted heat pump working with CO₂

Solar-Assisted Heat Pumps (SAHPs) consist of heat pump systems that work with solar sources as low-temperature thermal sources. There are two types of SAHPs: indirect solar-assisted heat pumps (IDX-SAHPs), where a secondary fluid is heated up in a solar collector and then it is sent to the evaporator, and direct solar-assisted heat pumps (DX-SAHPs), where the solar collector acts itself as the evaporator. The use of hybrid photovoltaic-thermal (PV-T) solar collectors in SAHPs has the advantage of providing additional electrical power to the system with a higher PV conversion efficiency due to the cooling of the cells. When using SAHPs, the evaporation temperature can be higher than in the case of air-to-refrigerant evaporators, and thus, the instantaneous COP turns out to be higher. Considering the recent international regulations call for reducing the GWP of employed refrigerants, using natural fluids such as CO₂ is increasingly growing in heat pump systems. At the Department of Industrial Engineering, a novel, innovative direct-expansion solar-assisted heat pump prototype working with CO₂ as a refrigerant has been installed. The study has been realized in the framework of Solair-HP CSEA project. The prototype is a 4 kW heat pump that can produce hot water. The heat pump can work alternatively with a finned coil evaporator or a PV-T solar evaporator. The solar evaporator is a sheet-and-tube heat exchanger placed in thermal contact with the PV module, and it allows to evaporate the CO₂ while cooling the PV cells (Figure 3-6). Therefore, the PV-T collector has a double effect: it allows the evaporation of the CO₂ that flows in the tubes and cools down the photovoltaic cells, improving the PV conversion efficiency. The main objective of this system is to increase the seasonal coefficient of performance of the heat pump compared to an air source heat pump and reduce the overall electrical consumption by including the PV modules.



Figure 3-6: Solar-assisted heat pump prototype was installed at the Solar Energy Conversion Laboratory (Department of Industrial Engineering, University of Padova).

3.2.4 Activities at Polytechnica of Milan

During 2020, the research activities carried out at Polytechnic of Milan focused on the experimental comparison of the performance of a water-to-water heat pump that uses low-GWP refrigerants alternative to R134a.

An experimental set-up mimicking a water-to-water heat pump is available for studying refrigerant alternatives in drop-in applications. The layout of the experimental set-up is shown in Figure 3-7.

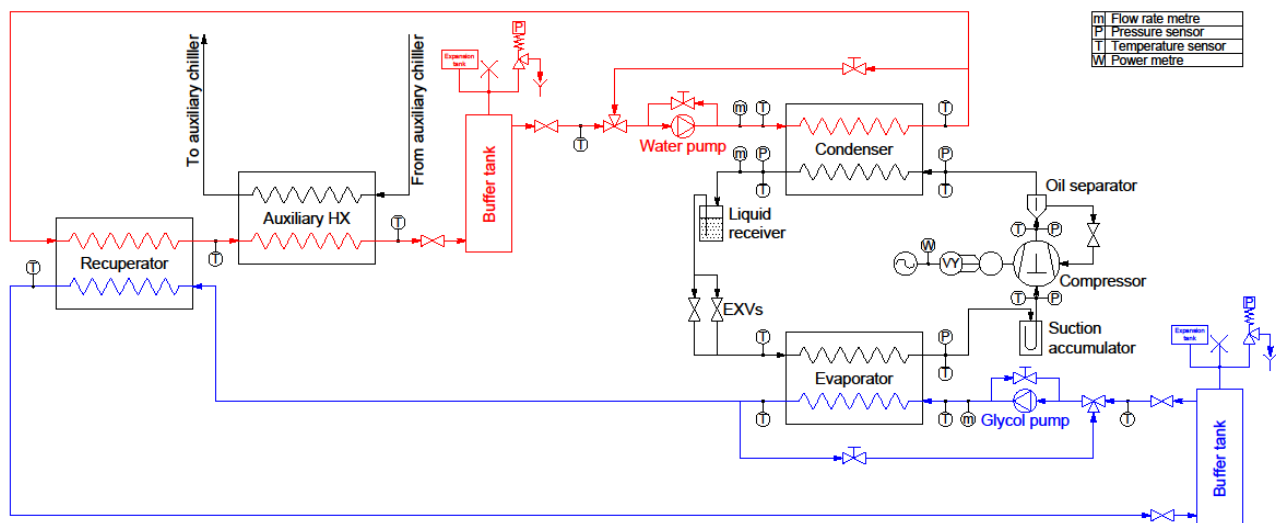

Figure 3-7: Layout of the experimental set-up.

The test rig consists of three different loops: the refrigerant loop, the cold water + ethylene glycol loop (evaporator loop), and the hot water loop (condenser loop). The main characteristics of the components in the refrigerant loop are reported in Table 3-2.



Table 3-2 Main characteristics of the refrigerant loop.

Component	Parameter	Range
Compressor	Swept volume @ 50 Hz	13.15 m ³ /h
	Shaft rotational frequency	30 Hz - 87 Hz
	Oil	POE ISO 32
	Oil charge	1.1 dm ³
Condenser	Height x Width x Depth	289 mm x 119 mm x 93.6 mm
	Number of plates	40
Evaporator	Height x Width x Depth	376 mm x 119 mm x 71.2 mm
	Number of plates	30
Expansion valve	Capacity range	1,200 W – 12,000 W
		1,690 W – 16,900 W
Liquid receiver	Volume	2.8 dm ³
Suction accumulator	Volume	2.33 dm ³
Oil separator	Type	Coalescence
	Volume	2.8 dm ³
Pumps	Nominal flow rate	28.7 m ³ /h
	Nominal head	160 kPa
	Shaft rotational frequency	16 Hz - 58 Hz
Recuperator	Height x Width x Depth	193 mm x 76 mm x 71.2 mm
	Number of plates	30

The experimental set-up is equipped with instrumentations allowing for measuring, acquiring, and storing the main parameters such as pressures, temperatures, flow rates, and power. Their main features are reported in Table 3-3.

Table 3-3: Measurement instrumentation range and accuracy.

Parameter	Instrument	Range	Accuracy
Refrigerant mass flow rate	Coriolis mass flow meter	0 kg/h - 300 kg/h	±0.15% r.v.
Refrigerant pressure (low side)	Pressure transducer	0 kPa - 700 kPa	±0.3% f.s.
Refrigerant pressure (high side)	Pressure transducer	0 kPa -4000 kPa	±0.3% f.s.
Refrigerant temperature	RTD Pt 100	243.15 K - 373.15 K	±0.1K
Compressor power	Power transducer	0 W – 4,000 W	±0.2% f.s.
Water mass flow rate	Vortex flow meter	0.21 m ³ /h - 3 m ³ /h	±2% r.v.
Water temperature	RTD Pt 100	263.15 K - 353.15 K	±0.1K

The test rig is used to compare the drop-in performance of R134a, R1234yf, R1234ze(E), R450A, and R513A under the testing conditions reported in Table 3-4. Tests 1-5 are carried out in pure drop-in conditions, whereas tests 6-10 are carried out to identify the rotational frequency of the compressor shaft that leads to the same heating capacity measured with R134a.

Table 3-4: Test Conditions

Run	Frequency	Superheating	Evaporator		Condenser	
			T _{OUT}	ΔT	T _{OUT}	ΔT
1	50	5 K	5 °C	5 K	35 °C	5 K
2	50	5 K	5 °C	5 K	45 °C	5 K
3	50	5 K	5 °C	5 K	55 °C	5 K
4	50	5 K	5 °C	5 K	65 °C	5 K
5	50	5 K	5 °C	5 K	75 °C	5 K
6	Identified	5 K	5 °C	5 K	35 °C	5 K
7	Identified	5 K	5 °C	5 K	45 °C	5 K
8	Identified	5 K	5 °C	5 K	55 °C	5 K
9	Identified	5 K	5 °C	5 K	65 °C	5 K
10	Identified	5 K	5 °C	5 K	75 °C	5 K

The heating capacity and the COP of the heat pump measured in drop-in conditions, i.e. under runs 1-5 conditions, are shown in Figure 3-8 and Figure 3-9, respectively. Starting from the heating capacity, it is possible to state that using any low-GWP alternative to R134a leads to a reduction of the heat pump heating capacity. The capacity reduction with R1234yf, R450A, or R513A is quite little since it lies in the range of 95%-99%, whereas a larger capacity reduction is achieved with R1234ze(E) since it is in the range of 77%-79%. A similar trend is found with the COP since the use of any alternative refrigerants leads to a COP reduction. The COP lies in the range 93%-99% when R1234yf or R513A are considered, while it is closer to R134a, in the range 98%-100%, with R1234ze(E) or R450A. Overall, the following trend is found: the closer to R134a is the heating capacity the lower is the COP and vice-versa.

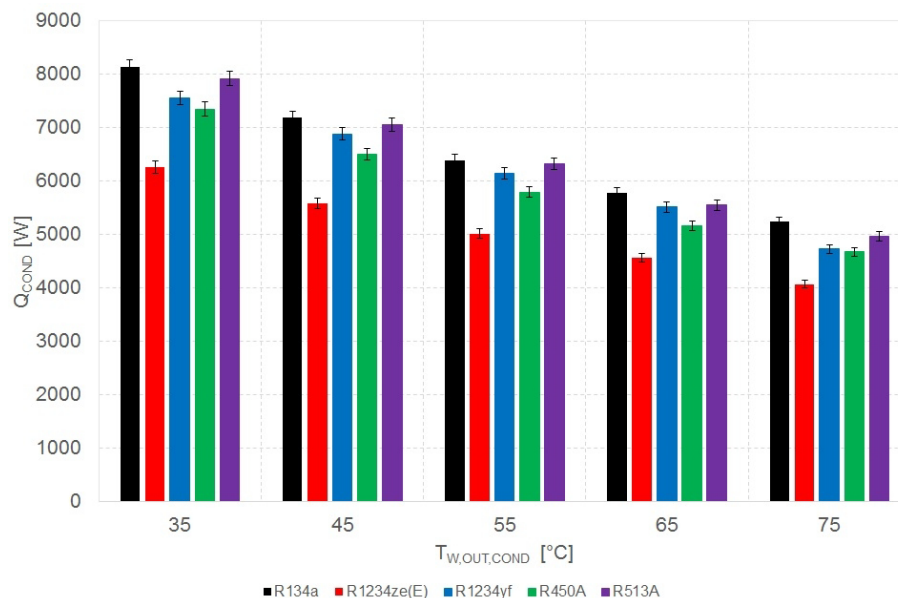

Figure 3-8: Heat pump heating capacity as a function of condenser outlet temperature for the five refrigerants considered under run 1-5 conditions.



Annex 54, Heat pump systems with low-GWP refrigerants

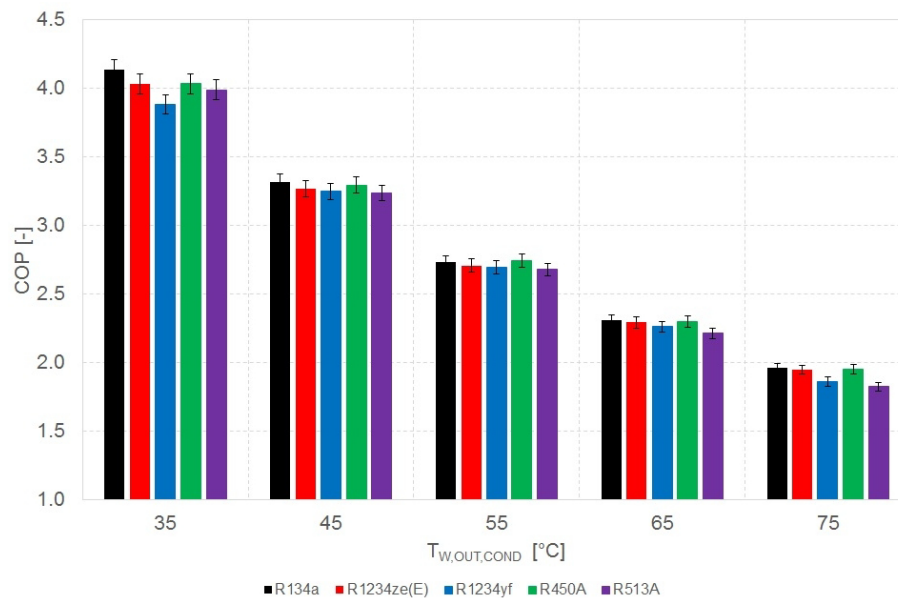

Figure 3-9: Heat pump COP as a function of condenser outlet temperature for the five refrigerants considered under run 1-5 conditions.

The rotational frequency of the compressor shaft and the COP of the heat pump measured under constant heating capacity conditions, i.e. under runs 6-10 conditions, are shown in Figure 3-10 and Figure 3-11, respectively. Discussing the data about the rotational frequency of the compressor shaft first, to let the heat pump supply the same R134a heating capacity when a low-GWP alternative is used, an increase in the rotational frequency of the compressor shaft is needed. The refrigerant that exhibits the lowest heating capacity at 50 Hz, i.e., R1234ze(E), requires the largest frequency increase, in the range of 10%-50%. Conversely, the frequency increase ranges from 2%-17% with all the other refrigerants since their heating capacity is more like that of R134a. The increase in shaft rotational frequency also leads to a reduction in the heat pump COP. The COP is within 93%-98% when R1234yf, R450A, or R513A are considered, whereas it lies in the range 82%-86% with the refrigerant R1234ze(E).

Overall, the following trend is found: the higher the rotational frequency of the compressor shaft, the lower the heat pump COP, and vice-versa.

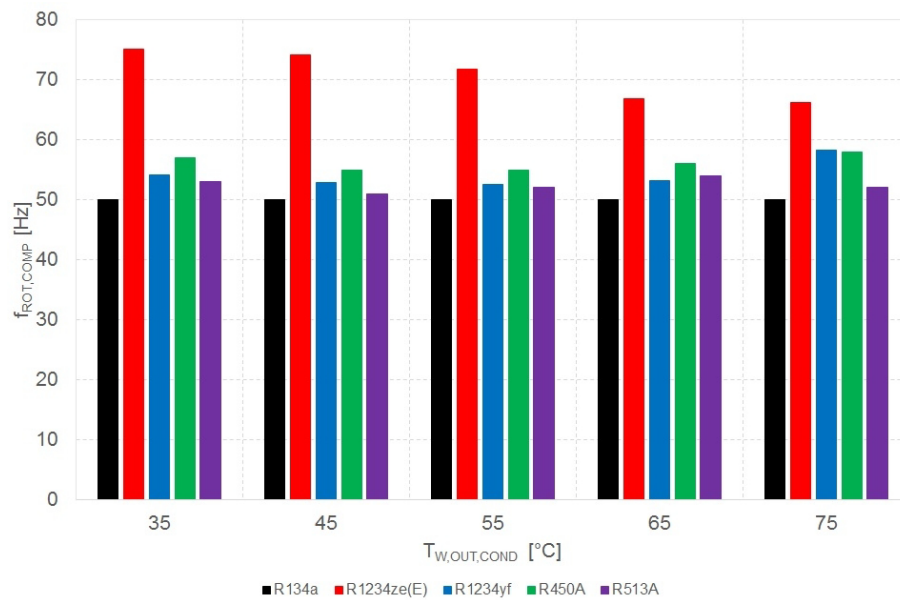

Figure 3-10: Rotational frequency of the compressor shaft as a function of condenser outlet temperature for the five refrigerants considered under run 6-10 conditions.

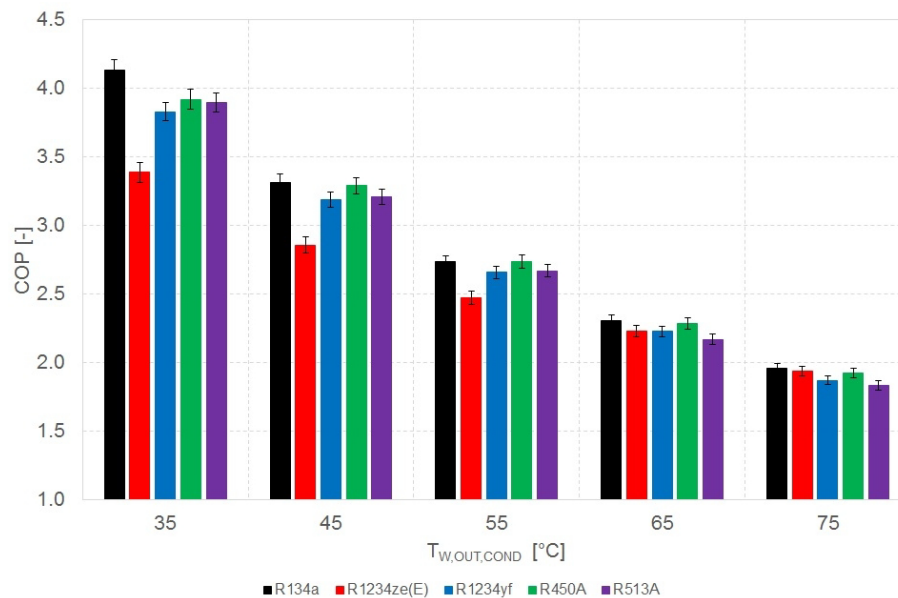

Figure 3-11: Heat pump COP as a function of condenser outlet temperature for the five refrigerants considered under run 6-10 conditions

3.2.5 Acknowledgment

The support of the Italian Ministry for Education and Research (MIUR) through the project PRIN 2015 (Grant Number 2015M8S2PA) is acknowledged.



3.2.6 References

- [1] Azzolin, M., Bortolin, S. Condensation and flow boiling heat transfer of a HFO/HFC binary mixture inside a minichannel. *International Journal of Thermal Sciences*, Vol. 159 (2021), 106638. doi:10.1016/j.ijthermalsci.2020.106638
- [2] Berto, A., Azzolin, M., Bortolin, S., Guzzardi, C., Del Col, D. Measurements and modelling of R455A and R452B flow boiling heat transfer inside channels. *International Journal of Refrigeration*, Vol. 120 (2020), pp. 271-284. doi:10.1016/j.ijrefrig.2020.08.007
- [3] Bobbo, S., Bet, A., Scattolini, M., Fedele, L. Saturated pressure measurements of cis-1-chloro-2,3,3,3- tetrafluoropropene (R1224yd (Z)) saturation pressure. *Journal of Chemical and Engineering Data*, Vol. 65 (2020), pp. 4263-4267. doi:10.1021/acs.jced.0c00231
- [4] Bortolin, S., Azzolin, M., Berto, A., Guzzardi, C., Del Col, D. Condensation and vaporization heat transfer of low-GWP mixtures. *Journal of Physics: Conference Series*, Vol. 1599 (2020), 012051. doi:10.1088/1742-6596/1599/1/012051
- [5] Fedele, L., Bobbo, S., Scattolini, M., Zilio, C., Akasaka, R. HCFO refrigerant cis-1-chloro-2,3,3,3 tetrafluoropropene [R1224yd(Z)]: Experimental assessment and correlation of the liquid density. *International Journal of Refrigeration*, Vol. 118, pp. 139-145. doi:10.1016/j.ijrefrig.2020.06.001
- [6] Molinaroli, L., Lucchini, A., Colombo, L.P.M., Bocchinfuso, F. First experimental results of the use of R1234yf and R1234ze(E) as drop-in substitutes for R134a in a water-to-water heat pump. *Journal of Physics: Conference Series* 1599 (2020), 012057. doi:10.1088/1742-6596/1599/1/012057
- [7] Colombo, L.P.M., Lucchini, A., Molinaroli, L. Experimental analysis of the use of R1234yf and R1234ze(E) as drop-in alternatives of R134a in a water-to-water heat pump. *International Journal of Refrigeration*, vol. 115 (2020), pp.18-27. doi: 10.1016/j.ijrefrig.2020.03.004.
- [8] Zanetti, E., Azzolin, M., Giroto, S., Del Col, D. Study of a PV-T collector working as an evaporator in a CO₂ solar assisted heat pump, 14th Gustav Lorentzen Conference, Kyoto, Japan, 6th- 9th December, 2020, Paper ID: 1046.



3.3 Research and Development Activities on Low-GWP Refrigerants in 2021

Prepared by:

Sergio Bobbo¹, Stefano Bortolin², Davide Del Col², Laura Fedele¹, Luca Molinaroli^{3*}

**¹National Research Council, Construction Technologies Institute
Corso Stati Uniti 4, 35127, Padova, Italy**

**²University of Padua, Department of Industrial Engineering
Via Venezia 1, 35131, Padova, Italy**

**³Polytechnic of Milan, Department of Energy Engineering
Via Raffaele Lambruschini 4/A, 20156, Milano (MI), Italy**

*** Corresponding Author: luca.molinaroli@polimi.it**

3.3.1 Summary

This report briefly summarizes the activities carried out during the 3rd year of Annex 54 in Italy.

Due to the Covid-19 emergency, the research activities slightly slowed down. Despite this, advances have been made in using low GWP refrigerants in heat pumps, as detailed in the following sections.

NB: Since the Italian team consists of three different research groups, the document is organized into four sections, one for each research group.

3.3.2 Activities at the National Research Council

3.3.2.1 Thermodynamic properties of low GWP refrigerants

As more extensively described in last year's country report, the main part of the activities of ITC-CNR on Low-GWP refrigerants is devoted to the measurements of some thermodynamic properties to evaluate the efficiency analysis of hydrofluoroolefins (HFOs). In particular, the laboratory of refrigerants and nanofluids is equipped with various instruments capable of measuring the main properties of refrigerants: saturated pressure of pure fluids, vapor-liquid equilibria (VLE) of binary mixtures, the compressed liquid density of both pure and mixed refrigerants, mutual solubility of refrigerants and lubricants, liquid and vapor thermal conductivity



Annex 54, Heat pump systems with low-GWP refrigerants

for both pure and mixed refrigerants. Due to the restrictions induced by the COVID-19, no further measurements could be taken in the last year. However, at present, measurements of VLE for the binary mixture R32+R1234yf and for the thermal conductivity of R1234ze(E) are in progress: the results will be available in the next weeks and will be presented in the next report.

In 2018, the ITC CNR research group performed a thorough analysis of the literature to evaluate the amount of experimental data available for the main thermodynamic and transport properties of low GWP refrigerants. These data are essential to developing the accurate Equations of state (thermodynamic properties) and dedicated equations (transport properties) necessary to properly design the components of the heat pump systems and to evaluate their performance. It was highlighted that only a few refrigerants (namely R1234yf, R1234ze(E), R1234ze(Z) and R1233zd(E)) were already sufficiently studied, while for all the other pure low GWP refrigerants there were scarce or null information. Even worse was the situation for refrigerant mixtures.

This year, this review was updated to evaluate the progress obtained in the last three years. Table 3-5 synthesizes the results of the review. For a given fluid, green, yellow, and red areas identify a property for which more than 1 set of data, 1 set or no sets, respectively, are available.

With respect to 2018, for only two new fluids (R1336mzz(Z) and R1224yd(Z)) enough data is available for almost all the properties. For eight fluids (R1243zf, R1123, R1123a, R154mzy(E), R1225ye(Z), R1336mzz(E), RE356mzz, and R1354myf(E)), there is a discreet or scarce amount of data, but several properties are not studied yet. For the other 5 fluids considered, no information at all is available in the literature. It is evident that consistent research activity is still necessary to cover the lack of data for the pure low GWP refrigerants. As referred to the mixtures, the situation is even worse. Recently, a review of the experimental data available for mixtures was performed by Bell et al. (2021)¹. They showed that most of the potential mixtures formed by HFOs have not been studied at all now and that only a few data are available for a restricted number of mixtures.

¹ Bell, I.H., Riccardi, D., Bazyleva, A., McLinden, M.O., 2021. Survey of Data and Models for Refrigerant Mixtures Containing Halogenated Olefins. *J. Chem. Eng. Data*, 66 (6), 2335-2354.



Table 3-5 - Sets of data available in the open literature on the thermodynamic and transport properties of low GWP pure refrigerants.

ASHRAE Designation	Thermodynamic Properties								Other Properties							
	Critical point		Saturated pressure		PVT		C ^o , C _p , C _v		Speed of sound		Thermal conductivity		Viscosity		Surface tension	
	Sets	Data	Sets	Data	Sets	Data	Sets	Data	Sets	Data	Sets	Data	Sets	Data	Sets	Data
R1234ze (E)	1	1	13	274	13	1516	6	332	5	551	2	1081	4	201	3	36
R1234yf	2	2	14	186	10	989	6	402	8	336	1	790	7	306	2	39
R1233zd(E)	1	1	5	150	7	675	2	44	2	290	1	115	5	213	3	27
R1234ze(Z)	1	1	7	226	7	653	1	94	1	38	1	45	2	(n.a.)	1	13
R1336mzz(Z)	1	1	7	77	5	653	1	140	1	183	1	1599	2	206		
R1224yd(Z)	1	1	2	46	4	162	1	36			1	112	2	136	2	44
R1243zf	2	2	5	185	3	619							1	14	2	25
R1123	2	2	3	56	4	349									1	16
R1132a	1	1	1	24	1	131			1	20						
R1354mzy(E)	1	1	1	14	3	183										
R1225ye(Z)			1	96	1	240										
R1336mzz(E)			1	17	1	169										
RE356mzz					1	105					2	159	1	116		
R1354myf(E)					1	47										
R1132(E)																
R1132(Z)																
R1141																
R1225ye(E)																
R1234ye(E)																

3.3.2.2 Heat pumps

As described in the last country report, ITC-CNR has recently been involved in two Horizon2020 EU projects dedicated to the development of ground source heat pumps (GSHPs) in all Europe (CHEAP-GSHPs and GEO4CIVHIC projects). The last one is still in progress and its deadline has been postponed to October 2023. CNR-ITC is involved in a specific activity aimed at identifying low-GWP refrigerants as substitutes for R134a (low pressure refrigerants) and R410A (high-pressure refrigerants). To perform the selection of the most promising substitutes, a homemade software based on MATLAB® environment and coupled with REFPROP 10.0 for the calculation of the thermodynamic properties has been developed. For each fluid, an energetic and exergetic analysis of the performance (COP and volumetric heating/cooling effect (VHE)) with several heat pump cycles schemes has been performed, assuming as boundary conditions those typical for geothermal applications in the different regions of Europe. The first part of the analysis has been performed on “transition” fluids characterized by GWP lower than the current HFCs (GWP<800). Various potential fluids have been considered after a survey of open literature. Table 3-6 and Table 3-7 report the fluids considered and their basic characteristics.



Table 3-6 - Characteristics of the potential substitutes for R410A (high pressure fluids).

Fluid	GWP	ASHRAE Safety Class [27]	Composition (wt %)	T _{crit} (K)	P _{crit} (MPa)	T Glide (K)
R410A	2088	A1	R32/R125 (50/50)	343.32	4.770	0.05
R32	675	A2L	R32 (100)	351.55	5.816	-
R454B	466	A2L	R32/R1234yf (68./31.1)	350.15	5.041	1
R452B	698	A2L	R32/R125/R1234yf(67/7/26)	350.25	5.200	0.9

Table 3-7 - Characteristics of the potential substitutes for R134a (low pressure fluids).

FLUID		GWP	NBP (°C)	Safety class (ASHRAE)	Components	Compositio (wt%)	T glide (K)
REFERENCE	R134a	1300	-26.1	A1	R32/R125	50/50	0
POTENTIAL ALTERNATIVES	R513A	631	-29.2	A1	R1234yf/R134a	56.0/44.0	0
	R515A	393	-18.0	A1	R1234ze(E)/R227ea	88/12	0
	R515B	293	-19.1	A1	R1234ze(E)/R227ea	91.1/8.9	0
	R516A	142	-29.4	A2L	R134a/R1234yf/R152a	8.5/77.5/14	0

The main results obtained till now can be synthesized as follows:

1. Within high-pressure fluids, R454B resulted to be the most promising substitute for R410A in all the analyzed cycles.
2. Within the low-pressure fluids, the most efficient fluid resulted to be R516A (+10% COP with reference to R134a).
3. The main drawback of these fluids is that they are weakly flammable fluids (A2L ASHRAE classification), and this obliges us to take suitable safety measures, with potentially higher costs.

The next step of the analysis will be the identification of very low GWP refrigerants (GWP<150) to meet the new regulations on F-gas. These fluids, probably mixtures rather than pure refrigerants, will have to guarantee an energy efficiency similar to that of traditional refrigerants and possibly a low or null flammability.

One of the activities of CNR ITC within the Geo4Civhic project is the monitoring of two geothermal heat pumps installed in the demo site at the CNR Research Area in Padova. The refrigerant R454B is used in both heat pumps as working fluid. The heat pumps are identical but are endowed with

two different control systems: one on-off, the other with inverter. The scope of the activity is testing the efficiency of the two heat pumps along one year of operation to evaluate the different energetic behavior of the two control systems by evaluating the heat exchange at the source (geothermal wells) and the sink (user) side by monitoring secondary fluids temperatures and flow rates at the corresponding heat exchangers. Moreover, the heat pump with an inverter is endowed with sensors to measure pressures, temperatures, and the refrigerant mass flow rate at the characteristic points of the cycle. Figure 3-12 shows the arrangement of the sensors on the refrigerant and secondary fluids circuits.

The heat pumps and the monitoring system are at present under testing. The first year acquisition program will start in the next weeks.

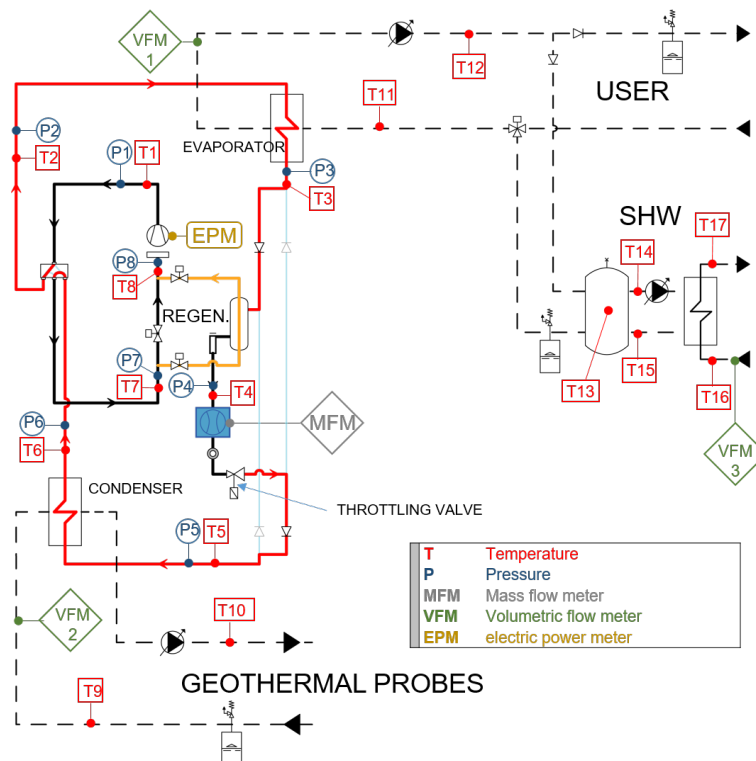

Figure 3-12 - Scheme of the monitoring system for the heat pump with inverter.

3.3.3 Activities at University of Padua

The research activity performed at the Department of Industrial Engineering (University of Padova) during 2021 has been focused on condensation heat transfer measurements with low-GWP fluids and on the experimental investigation of a solar assisted heat pump working with CO₂.

3.3.3.1 In-tube condensation with low-GWP refrigerants

R1234ze(E) has emerged in recent years as a low Global Warming Potential substitute for R134a in heat pumps. As a drawback, R1234ze(E) is classified as a mildly flammable fluid (A2L class, ANSI/ASHRAE classification) and, in the search for non-flammable alternatives to R134a, hydrofluorocarbon/hydrofluoroolefin binary mixtures have been considered.

Low-GWP refrigerant mixtures that fall in the A1 non-flammable category are frequently sought by the industry since they can be used as drop-in fluids in existing systems and, in the case of new installations, they do not require more stringent safety measures. Among R134a low-GWP substitutes that belong to A1 class, mixtures R450A (R1234ze(E)/R134a at 58.0/42.0% by mass composition) and R515B (R1234ze(E)/R227ea at 91.1/8.9% by mass) can be identified. Most of the studies available in the literature on R450A and R515B focus on the employment of these fluids as drop-in replacements in vapor compression refrigeration systems working with R134a. Less attention has been addressed to the condensation heat transfer coefficient of these fluids, especially inside minichannels. Furthermore, there is a lack of experimental studies on HFCs and HFOs mixtures providing two-phase heat transfer data together with flow pattern visualizations. These complementary data are fundamental for the development of new heat transfer correlations, particularly at low mass flux conditions (below $100 \text{ kg m}^{-2} \text{ s}^{-1}$) which can be encountered in vapor compression systems with inverter-driven compressors.

Condensation tests have been performed at the University of Padova with R1234ze(E) and with binary non-flammable mixtures R450A and R515B inside two channels with inner diameter equal to 3.38 mm and 0.96 mm. R515B is an azeotropic mixtures ($\text{GWP}_{100\text{-years}} = 299$) whereas R450A is a near-azeotropic mixture with 0.6 K temperature glide at 40°C dew temperature ($\text{GWP}_{100\text{-years}} = 547$).

The test rig used during the experimental campaign consists of a primary refrigerant loop (oil-free) and three auxiliary water circuits. In the refrigerant loop, the subcooled liquid exits from a tube-in-tube heat exchanger (post-condenser) which operates with distilled water as secondary fluid, and it enters a magnetic-driven gear pump. The refrigerant is then vaporized and superheated inside a tube-in-tube heat exchanger (evaporator). After the evaporator, the refrigerant enters the 0.96 mm diameter or the 3.4 mm diameter test section where it is partially or fully condensed. The 3.4 mm diameter test section is composed of two tube-in-tube heat exchangers for heat transfer measurements separated by a 70 mm long borosilicate glass tube for flow pattern visualizations. Flow pattern visualizations have been recorded using a high-speed camera coupled with macro lens and a LED illumination system.

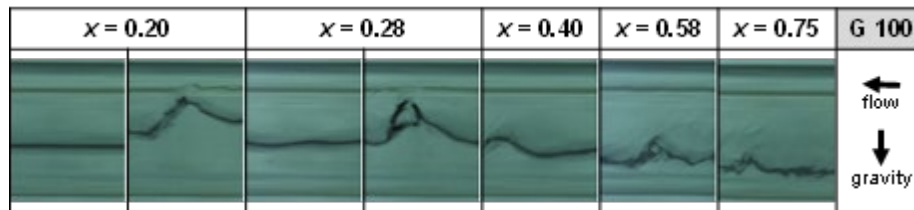

Figure 3-13- Two-phase flow pattern visualizations of R1234ze(E) at 40°C saturation temperature inside the 3.4 mm inner diameter horizontal tube. The selected frames correspond to mass velocity $G = 100 \text{ kg m}^{-2} \text{ s}^{-1}$ and five different values of vapor quality.

Figure 3-13 shows flow patterns recorded during condensation of R1234ze(E) at a mass velocity equal to $100 \text{ kg m}^{-2} \text{ s}^{-1}$ and different vapor quality. Stratified wavy flow can be observed for a wide range of vapor qualities x . From $x = 0.75$ to $x = 0.20$, the film thickness at the bottom progressively increases, and the interfacial waves become large enough to reach the upper part of the tube. It can be noticed that, with the decreasing vapor quality, the liquid-vapor interface between two large amplitude waves becomes smooth. Considering the whole range of mass velocities and all the three fluids investigated (R1234ze(E), R450A, R515B), four regimes were detected in the 3.38 mm diameter channel: annular, stratified-wavy, stratified-smooth, and slug.



Annex 54, Heat pump systems with low-GWP refrigerants

Heat transfer coefficients have been measured at 40 °C saturation temperature and mass velocity from 40 kg m⁻² s⁻¹ to 600 kg m⁻² s⁻¹. At the same mass velocity, vapor quality, and channel diameter, R1234ze(E), R450A, and R515B display similar values of heat transfer coefficient. For each fluid, at the same conditions of vapor quality and mass velocity, the heat transfer coefficient is found to increase when reducing the channel diameter. The prediction accuracy of condensation heat transfer models has been assessed against the experimental results.

Adiabatic two-phase frictional pressure drops have been measured inside the 0.96 mm minichannel at mass velocities equal to 200 and 400 kg m⁻² s⁻¹. At given mass velocity and vapor quality, R1234ze(E) and R515B present the same pressure gradient, whereas R450A shows a lower pressure drop.

The comparison among different refrigerants during condensation should also consider the pressure drop of the fluid, which affects the saturation temperature and, thus, the mean effective driving temperature difference in the condenser. To allow the comparison among R134a and the drop-in candidates R1234ze(E), R515B, and R450A, a performance evaluation criterion has been adopted.

3.3.3.2 Solar-assisted heat pump working with CO₂

Solar-assisted heat pumps (SAHPs) exploit solar energy as a low-temperature thermal source. There are two types of SAHPs: indirect solar-assisted heat pumps (IDX-SAHP), where a secondary fluid is heated up by solar collectors and then is sent to the evaporator, and direct solar-assisted heat pumps (DX-SAHPs), where the solar collectors act as the evaporator. However, a solar evaporator is not able to absorb enough energy in the case of low or absent solar irradiance, and thus, a dual-source heat pump working both with solar and air sources can be used to guarantee the operation of the heat pump regardless of the presence of solar irradiance. Furthermore, the use of hybrid photovoltaic-thermal (PV-T) solar collectors in DX-SAHPs, allows the system to achieve higher photovoltaic (P.V.) conversion efficiency due to the cooling of the cells.

With the recent restrictions on the use of high GWP refrigerants, the use of environmentally friendly or natural fluids, such as CO₂, is increasingly growing. However, in the literature, there are few experimental studies on DX-SAHPs working with CO₂ as the refrigerant, and there are no experimental works on DX-SAHPs working with PV-T solar collectors and CO₂ as operative fluid.

Starting from this background, a novel direct-expansion solar-assisted heat pump prototype working with CO₂ has been installed at the Department of Industrial Engineering. The study is realized in the framework of the Solair-HP CSEA project. The prototype has a nominal heating capacity equal to 5 kW at the maximum compressor speed. The dual source heat pump can work with air or solar energy as a low-temperature source at the evaporator. The solar collector is a hybrid photovoltaic module coupled with a sheet-and-tube heat exchanger that works as an evaporator.

The heat pump has been tested in real environmental conditions to investigate its performance when working in air mode with the finned coil evaporator and when working in solar mode with the PV-T evaporator. The PV-T evaporator has been studied to determine its thermal efficiency curve and a model based on the experimental characterization of the heat pump has been developed.



Figure 3-14 - Solar assisted heat pump prototype working with CO₂ installed at the Solar Energy Conversion Laboratory (Department of Industrial Engineering, University of Padova).

3.3.4 Activities at Polytechnic of Milan

During 2021, the research activities carried out at Polytechnic of Milan went on slowly since a general revision of the experimental set-up was made. As a result, the analysis of low-GWP refrigerants was limited to R515B and the comparison with R134a was made in some selected conditions. The experimental set-up and the experimental methodology used to assess the performance of HFO described in the 2020 country report were used to assess the performance of that refrigerant. For the sake of clarity, the layout of the experimental set-up, the main characteristics of its components, and the main characteristics of the instrumentation are reported in Figure 3-15, Table 3-8, and Table 3-9 respectively. More information is available in the 2020 country report.

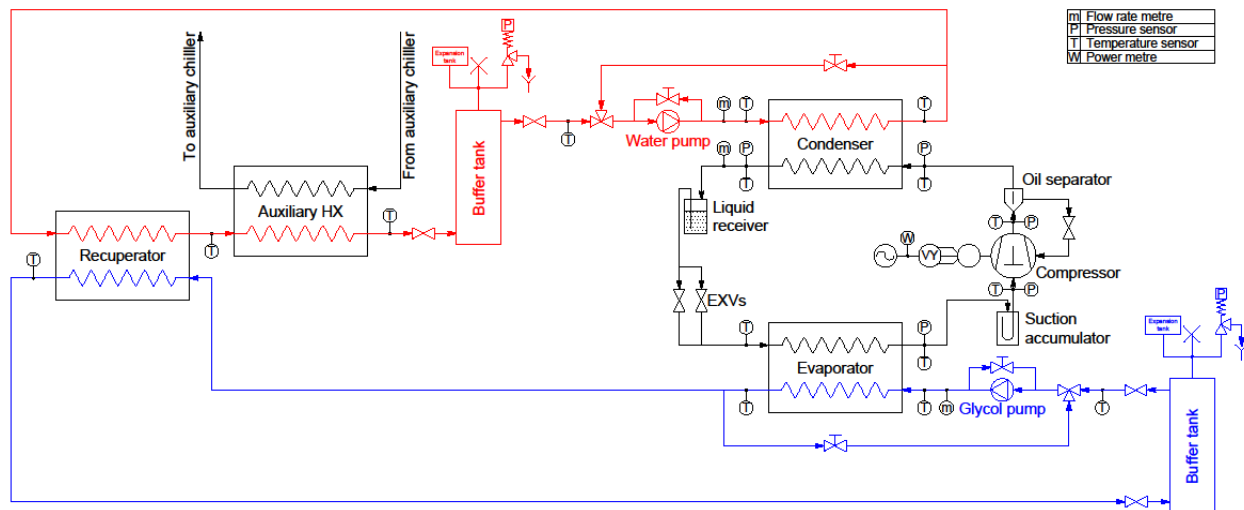

Figure 3-15 - Layout of the experimental set-up



Table 3-8 - Main characteristics of the refrigerant loop

Component	Parameter	Range
Compressor	Swept volume @ 50 Hz	13.15 m ³ /h
	Shaft rotational frequency	30 Hz - 87 Hz
	Oil	POE ISO 32
	Oil charge	1.1 dm ³
Condenser	Area	1.18 m ²
	Number of plates	40
Evaporator	Area	1.12 m ²
	Number of plates	30
Expansion valve	Capacity range	175 W - 1750 W
		1690 W - 16900 W
Liquid receiver	Volume	2.8 dm ³
Oil separator	Type	Coalescence
	Volume	2.8 dm ³

Table 3-9 - Measurement instrumentation range and accuracy.

Parameter	Instrument	Range	Accuracy
Refrigerant mass flow rate	Coriolis mass flow meter	0 kg/h - 300 kg/h	±0.15% r.v.
Refrigerant pressure (low side)	Pressure transducer	0 kPa - 700 kPa	±0.3% f.s.
Refrigerant pressure (high side)	Pressure transducer	0 kPa - 4000 kPa	±0.3% f.s.
Refrigerant temperature	RTD Pt 100	243.15 K - 373.15 K	±0.1K
Compressor power	Power transducer	0 W - 4000 W	±0.2% f.s.
Water mass flow rate	Vortex flow meter	0.21 m ³ /h - 3 m ³ /h	±2% r.v.
Water temperature	RTD Pt 100	263.15 K - 353.15 K	±0.1K

The test rig is used to compare the performance of R515B to those achieved with R134a and R1234ze(E) in a drop-in application. The testing conditions are reported in Table 3-10 and consist of 5 tests at constant evaporator inlet and outlet temperatures and variable condenser inlet and outlet temperatures.

Table 3-10 - Testing condition used to compare R515B with R134a and R1234ze(E).

Run	Frequency	Superheating	Evaporator		Condenser	
			T _{IN}	T _{OUT}	T _{IN}	T _{OUT}
1	50	5 K	10 °C	5 °C	30 °C	35 °C
2	50	5 K	10 °C	5 °C	40 °C	45 °C
3	50	5 K	10 °C	5 °C	50 °C	55 °C
4	50	5 K	10 °C	5 °C	60 °C	65 °C
5	50	5 K	10 °C	5 °C	70 °C	75 °C

The heating capacity and the COP of the heat pump are shown in Figure 3-16 and Figure 3-17 respectively. Starting from the heating capacity, it is possible to state that the use of R515B leads to a reduction of the heat pump heating capacity. The capacity reduction is quite large since, with this refrigerant, a capacity in the range of 78%-80% is achieved. Conversely, the trend of the COP is the opposite since a slight increase, in the range of 103%-105%, is found.

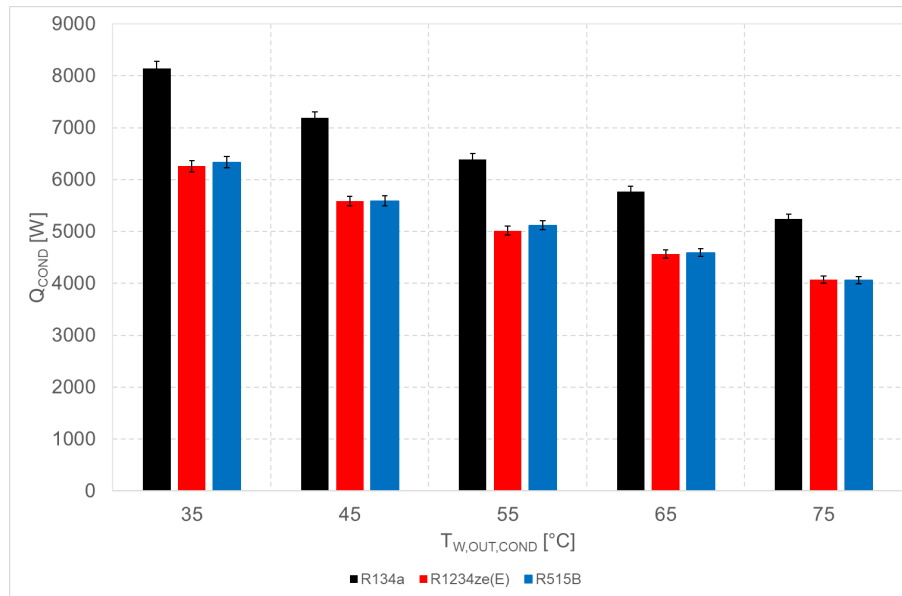

Figure 3-16 - Heat pump heating capacity as a function of condenser outlet temperature for the three refrigerants considered.

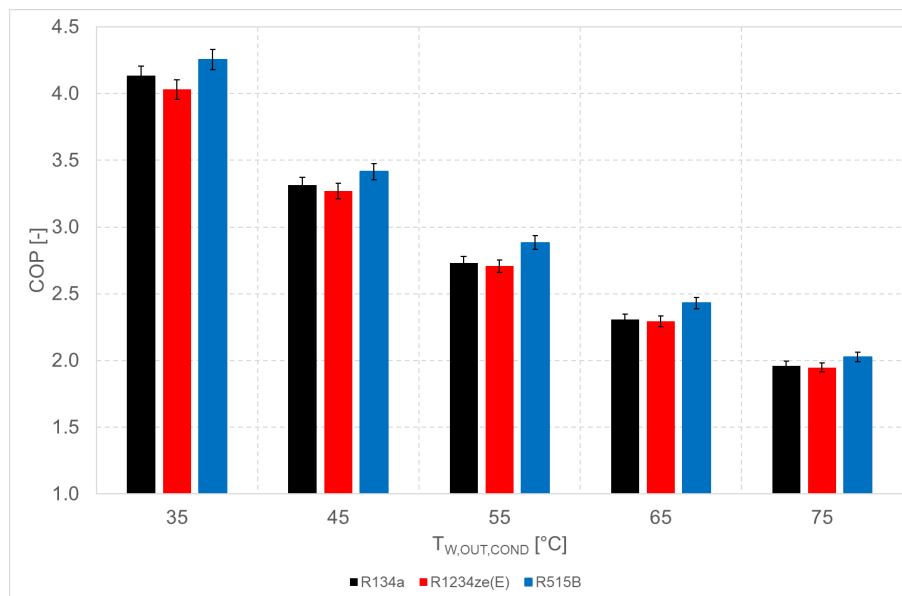

Figure 3-17 - Heat pump COP as a function of condenser outlet temperature for the three refrigerants considered.

3.3.5 References

M. Azzolin, S. Bortolin. Condensation and flow boiling heat transfer of a HFO/HFC binary mixture inside a minichannel. International Journal of Thermal Sciences, Vol. 159 (2021), 106638. DOI:10.1016/j.ijthermalsci.2020.106638



Annex 54, Heat pump systems with low-GWP refrigerants

A. Berto, M. Azzolin, S. Bortolin, C. Guzzardi, D. Del Col. Measurements and modelling of R455A and R452B flow boiling heat transfer inside channels. *International Journal of Refrigeration*, Vol. 120 (2020), pp. 271–284. DOI:10.1016/j.ijrefrig.2020.08.007

S. Bortolin, M. Azzolin, A. Berto, C. Guzzardi, D. Del Col. Condensation and vaporization heat transfer of low-GWP mixtures. *Journal of Physics: Conference Series*, Vol. 1599 (2020), 012051. DOI:10.1088/1742-6596/1599/1/012051

E. Zanetti, M. Azzolin, S. Girotto, D. Del Col, Study of a PV-T collector working as an evaporator in a CO₂ solar assisted heat pump, 14th Gustav Lorentzen Conference, Kyoto, Japan, 6th-9th December, 2020, Paper ID: 1046.

3.4 Research and Development Activities on Low-GWP Refrigerants in 2023

3.4.1 Activities at the National Research Council

As anticipated in the previous reports, CNR ITC is at the moment involved in some projects on the theme of heat pumps. Two of them (Geo4Civhic and ECHO) are European projects, while one is a bilateral project within an agreement between the Italian CNR and the Korean NRF. In this year, a further proposal (TechPump) has been submitted for a European project on heat pumps for residential applications. Here below a synthesis of the activities performed within these projects in the last year is reported.

3.4.1.1 UE project Geo4Civhic

The project will be completed at the end of November 2023. As already reported, CNR-ITC is involved in a specific activity aimed at identifying low-GWP refrigerants as long-term substitutes for R134a (low-pressure refrigerants) and R410A (high-pressure refrigerants) as working fluids in geothermal heat pumps. After a comparison among the most promising refrigerants, both pure and mixtures, isobutane (R600a) has been selected to build a prototype of heat pump for residential applications. R600a promises the best energetic performance (COP), even if its volumetric efficiency is quite low. One problem of R600a is its high flammability, but the installation of the heat pump outside the building and the adoption of some safety measures should easily overcome the problem.

In the last months, the R600a prototype has been designed, built, and installed in a small building within the research area of CNR in Padova. The prototype has been endowed with sensors to measure pressures, temperatures, and the secondary fluids flow rates at the characteristic points of the system. In the last weeks and till the end of the project, the geothermal heat pump prototype will be monitored, and its performances will be compared with those of a similar geothermal heat pump working with the refrigerant R454B, characterized by higher GWP.

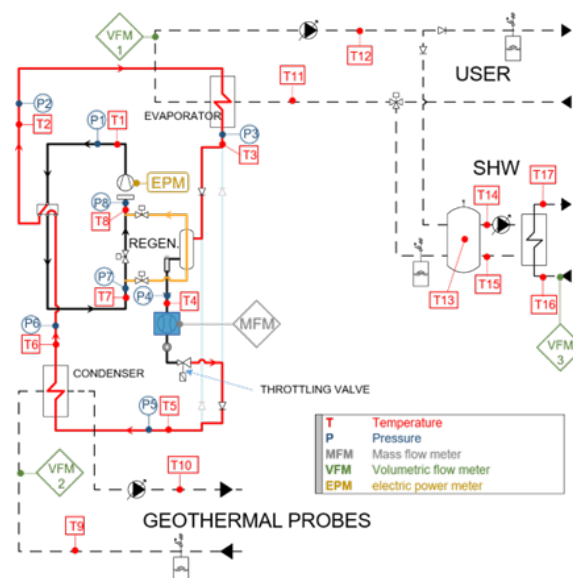

Figure 3-18 – Scheme of the monitoring system for the R600a heat pump with inverter.

Figure 3-18 shows the arrangement of the sensors on the refrigerant and secondary fluids circuits.

3.4.1.2 UE project ECHO

The objective of the project is to develop and demonstrate new modular, compact, high-performance and Plug&Play thermal energy storage (TES) solutions for heating, cooling, and domestic hot water (DWH). The ECHO project has the aim to provide a key tool for thermal energy storage in the context of sector coupling, i.e. the synergy between the electricity sector and other energy sectors, such as heating, cooling, or industrial processes. The ECHO system will be adapted to different energy scenarios. Furthermore, its modularity will allow it to be used at different scales, from small apartments to larger buildings. Figure 3-19 shows the conceptual scheme of the TES and heat pump system. The developed systems will be adaptable to different

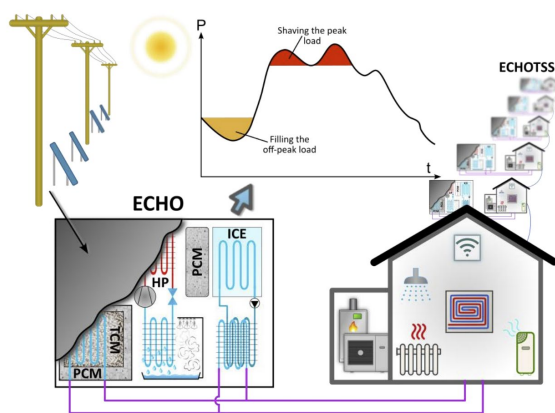

Figure 3-19 – Conceptual scheme of ECHO system.

energy sources and user demands, setting more suitable configuration parameters, such as the reactor size and TCMs quantity. It will be feasible to be charged directly by means of an internal heat pump, exploiting the electricity overproduction from the grid, or directly connecting to renewable energy sources installed in the building, as PV panels, or assisted by solar panel. The ambition is to exploit a power rate not less than 3 kW for charging of 1 m³ TCMs reactor with a temperature around 80-90 °C provided by the internal heat pump, working with the off-peak electricity, or directly by the solar energy, if locally available. The employed innovative heat pump will be developed in order to maximize its efficiency and minimize GHG emissions.

The first year of the project (2023) has been devoted in particular to the development of the thermochemical material (TCM) necessary to the thermal energy storage (TES). The heat pump will be successively developed on the base of the requirements of the TES.

3.4.1.3 Bilateral project CNR - Korean NRF

The project has the aim to identify new low GWP refrigerants to be applied in residential heat pumps. In the last year, the activity of CNR ITC has been devoted to a careful analysis of the literature to select low GWP (<150) refrigerants interesting for heat pumps for which no thermodynamic properties were available. The ternary mixture R600a+R1234yf+R1234zf has been finally identified. After that, the VLE of the binary mixtures R600a+R1234yf and R600a+R1234zf have been measured in the range of temperatures between 283.15 K and 323.15 K. The VLE for the third binary mixture, R1234yf+R1234zf, was already known. This allowed to calculate the binary interaction parameters of the three binary mixtures interacting within the ternary mixture of interest. Then, it was possible to calculate the thermodynamic properties of the ternary mixture based on a Helmholtz EoS available in REFPROP 10.0.

With these premises, the ternary mixture R600a+R1234yf+R1234zf will be tested this year in a heat pump prototype installed at the laboratories of the Seoul National University (SNU). The tests will be performed at various boundary conditions, and the results will be compared with those obtained by testing R134a as the reference fluid to evaluate the suitability of the selected ternary mixture as a potential low-impact refrigerant in heat pump applications.

3.4.2 Activities at University of Padua

The research activity performed at the University of Padova - Department of Industrial Engineering during 2023 has been focused on three main topics: condensation heat transfer and pressure drop of R1234yf/HFC mixtures inside small diameter channels; experimental and numerical analysis of a CO₂ dual-source heat pump with PVT evaporators for residential heating applications; experimental investigation of large scroll compressors working with low-GWP refrigerants.

3.4.2.1 In-tube condensation with low-GWP refrigerants mixtures

In the last years, hydrofluoroolefins (HFOs) R1234yf and R1234ze(E) were proposed as substitutes for R134a. To improve the cycle efficiency and the volumetric cooling capacity, mixtures of HFOs and HFCs have been considered. Condensation heat transfer, flow pattern transitions, and two-phase frictional pressure drop have been investigated with azeotropic mixtures R513A (R1234yf/R134a 56/44% by mass) and R516A (R1234yf/R152a/R134a 77.5/14/8.5% by mass) inside two horizontal channels with 0.96 mm and 3.38 mm internal diameter. Tests at low mass fluxes ($G < 100 \text{ kg m}^{-2} \text{ s}^{-1}$) have been conducted with the aim of better investigating the condensation heat transfer at such experimental conditions, which are frequently experienced in heat pumps when working under partial loads.

The test rig (Figure 3-20) used during the experimental campaign consists of a primary refrigerant loop (oil-free) and three auxiliary water circuits. In the refrigerant loop, the subcooled liquid exits from a tube-in-tube heat exchanger (post-condenser), which operates with distilled water as secondary fluid and enters a magnetic-driven gear pump. The refrigerant is then vaporized and superheated inside a tube-in-tube heat exchanger (evaporator). After the evaporator, the refrigerant enters the 0.96 mm diameter or the 3.4 mm diameter test sections, where it is partially or fully condensed. The 3.4 mm diameter test section is composed of two tube-in-tube heat exchangers for heat transfer measurements separated by a 70 mm long borosilicate glass tube for flow pattern visualizations (Figure 3-21).

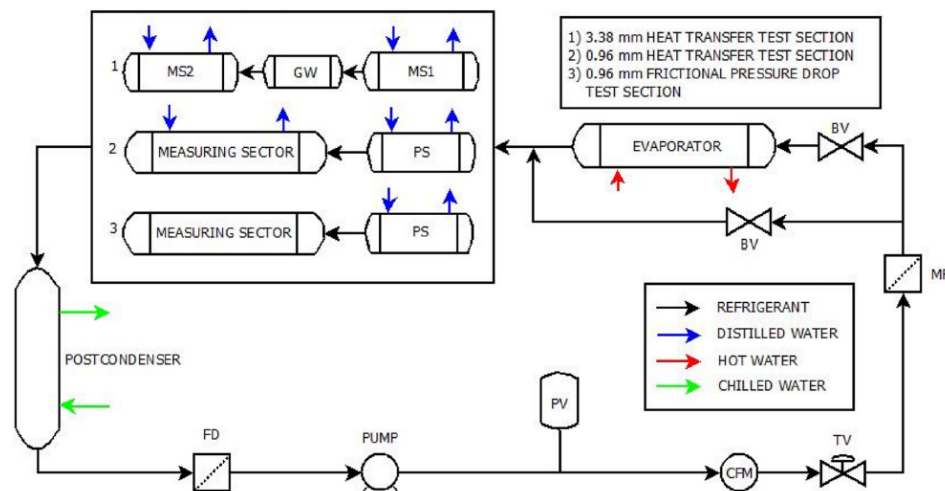

Figure 3-20 – Layout of the experimental setup available at the University of Padova for two-phase heat transfer and pressure drop measurements.

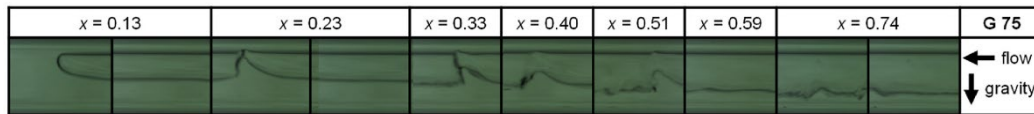

Figure 3-21. Two-phase flow pattern visualizations of R513A at 40 °C saturation temperature inside the 3.38 mm channel. The selected frames correspond to mass velocity $G = 75 \text{ kg m}^{-2} \text{ s}^{-1}$ and seven different values of vapor quality.

The heat transfer coefficients measured in the 0.96 mm diameter test section are higher than those measured at the same working conditions in the 3.38 mm channel. The saturation-to-wall temperature difference was not found to influence the heat transfer coefficient measured in the 0.96 mm channel. Instead, in the 3.38 mm test section, its effect is not negligible at mass fluxes between $40 \text{ kg m}^{-2} \text{ s}^{-1}$ and $100 \text{ kg m}^{-2} \text{ s}^{-1}$ (the higher the saturation-to-wall temperature difference, the lower the heat transfer coefficient). The heat transfer coefficient of R516A is slightly higher than the one of R513A at the same operating conditions, due to the lower vapor density and higher vapor velocity. Regarding two-phase frictional pressure drops, at the same mass flux and vapor quality, R516A displays a slightly higher-pressure gradient and saturation temperature drop as compared to R513A. An Artificial Neural Network (ANN) model was developed for the prediction of the condensation heat transfer coefficient.

3.4.2.2 Experimental and numerical analysis of a CO₂ dual-source heat pump with PVT evaporators for residential heating applications

The use of CO₂ as a refrigerant in heat pump applications is very promising. One of the main advantages of carbon dioxide is the possibility of providing a high-temperature lift between the water inlet and outlet when using a transcritical cycle. For this reason, the transcritical CO₂ cycle is particularly suitable for domestic hot water production. Integrating renewables and heat pumps becomes crucial in the transition to more sustainable heat pump systems. Dual-source solar-assisted heat pumps exploit solar energy and air as low-temperature heat sources. However, the efficiency of solar-based systems is strictly related to weather conditions, location, and time. Therefore, there is a need for accurate models to be used in dynamic simulations of these systems and perform detailed performance analyses.



Figure 3-22a. Heat pump prototype installed at the Solar Energy Conversion Laboratory (University of Padova).



b. Picture of water tanks, brazed plate heat exchanger and flow meters installed in the water loop.



The research activity at the University of Padova has been devoted to experimental tests and dynamic simulations of a dual-source (solar and air) CO₂ heat pump system for hot water provision (Figure 3-22). The heat pump can work alternatively with two evaporators: a conventional finned-coil heat exchanger or a photovoltaic-thermal (PVT) collector. Experimental tests on the heat pump have been conducted in dynamic conditions both in air and solar modes. When operating in solar mode, the experimental tests showed an increase in photovoltaic power production due to the cooling effect of the refrigerant evaporating in the collectors. A TRNSYS Type modelling of the dual-source heat pump was developed. The dynamic model, simulating the operating conditions of the dual-source heat pump prototype and the hydronic circuit, was validated against experimental data. The validated model is a useful tool for performing seasonal simulations of a CO₂ heat pump operating in solar and air modes. Future works will focus on developing a control strategy to select the thermal sources.

3.4.2.3 Experimental investigation of large scroll compressors working low-GWP refrigerants

An experimental study on the use of low GWP refrigerants as drop-in alternatives to R134a in a water-to-water vapor compression system has been performed. The refrigerants used are: R1234ze(E), R152a, R516A, R515B, R450A and R513A. The system is composed of two large scroll compressors (swept volume for each compressor equal to 222.5 m³/h) working in parallel. Experimental tests have been carried out at full and partial loads. Experimental data have been used to investigate the efficiencies of a scroll compressor with a large swept volume and to tune two predicting methods.

3.4.3 Activities at Polytechnic of Milan

During 2023, both experimental and numerical research activities were carried out at Polytechnic of Milan.

From the experimental point of view, the experimental set-up and the experimental methodology in the 2020 country report were used to assess the influence of the R513A refrigerant charge on the performance of the heat pump. For the sake of clarity, the layout of the experimental set-up, the main characteristics of its components, and the main characteristics of the instrumentation are reported in Figure 3-23, Table 3-11, and Table 3-12, respectively. More information is available in the 2020 country report.

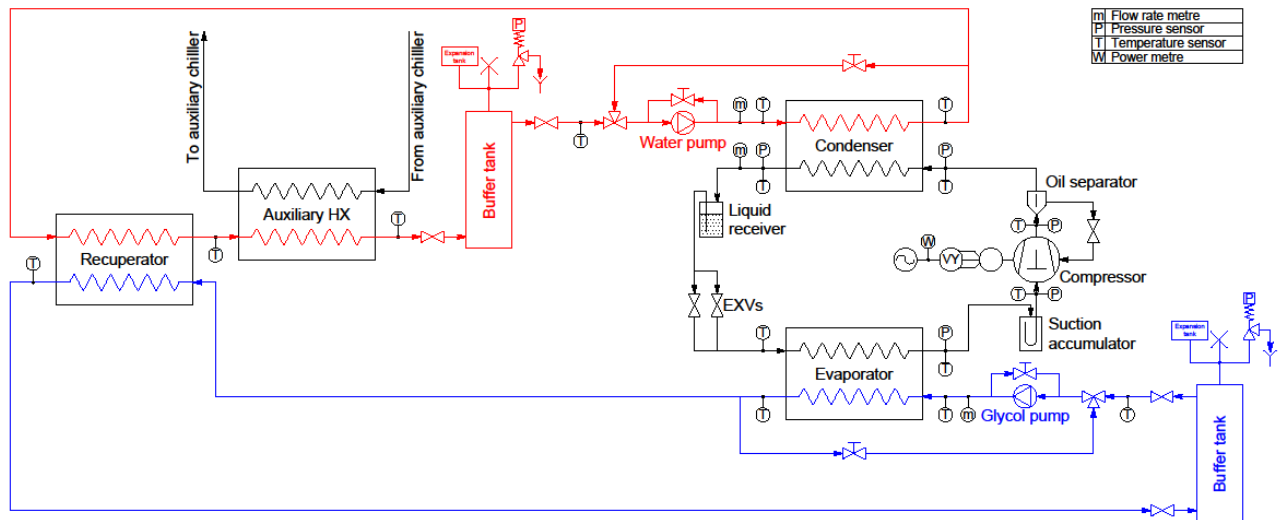

Figure 3-23 – Layout of the experimental set-up.

Table 3-11 – Measurement instrumentation range and accuracy.

Parameter	Instrument	Range	Accuracy
Refrigerant mass flow rate	Coriolis mass flow meter	0 kg/h - 300 kg/h	±0.15% r.v.
Refrigerant pressure (low side)	Pressure transducer	0 kPa - 700 kPa	±0.3% f.s.
Refrigerant pressure (high side)	Pressure transducer	0 kPa - 4000 kPa	±0.3% f.s.
Refrigerant temperature	RTD Pt 100	243.15 K - 373.15 K	±0.1K
Compressor power	Power transducer	0 W - 4000 W	±0.2% f.s.
Water mass flow rate	Vortex flow meter	0.21 m ³ /h - 3 m ³ /h	±2% r.v.
Water temperature	RTD Pt 100	263.15 K - 353.15 K	±0.1K

Table 3-12 – Main characteristics of the refrigerant loop.

Component	Parameter	Range
Compressor	Swept volume @ 50 Hz	13.15 m ³ /h
	Shaft rotational frequency	30 Hz - 87 Hz
	Oil	POE ISO 32
	Oil charge	1.1 dm ³
Condenser	Area	1.18 m ²
	Number of plates	40
Evaporator	Area	1.12 m ²
	Number of plates	30
Expansion valve	Capacity range	175 W - 1750 W
		1690 W - 16900 W
Liquid receiver	Volume	2.8 dm ³
Oil separator	Type	Coalescence
	Volume	2.8 dm ³



The performance of the heat pump was assessed test considering a charge range within 35%-100% of the nominal value and fixing the temperatures of the secondary fluids at heat exchangers inlet and outlet. The testing conditions are reported in Table 3-13.

Table 3-13 – Testing condition used to assess the influence of R513A charge on heat pump performance.

Charge	Evaporator		Condenser	
	T _{IN}	T _{OUT}	T _{IN}	T _{OUT}
35%-100%	10 °C	5 °C	40 °C	45 °C

The results show that there exist three different zones in which all the heat pump parameters (COP, heating capacity, operating pressures, and expansion valve opening) exhibit peculiar trends with the charge decrease:

- Subcooling sensitivity zone: zone in which the subcooling reduces rapidly as the charge reduces.
- Constant parameters zone: zone in which all the parameters of the heat pump do not change with the charge reduction.
- Compressor failure risk zone: zone in which the expansion valve is not able anymore to control the refrigerant superheating at the evaporator outlet (compressor suction), which becomes very high.

The extension of these zones is determined by the size of the liquid receiver that is installed in the heat pump: the larger this component, the wider the zone 2. Indeed, this zone is the result of a two-phase mixture in the liquid receiver which set constant condensing pressure and saturated liquid condition at the outlet of the condenser and the inlet of the expansion valve.

Besides this activity, a second experimental activity about fault detection and diagnosis has begun (and is still ongoing). First, the heat pump was tested under nominal, fault-free conditions and the experimental data is (“is” because this part of the activity is ongoing, A/N) used to train an Artificial Neural Network (ANN). Then, the same heat pump was tested in faulty conditions in which common faults such as refrigerant leakage, evaporator fouling, and expansion valve blockage were experimentally simulated. The ANN previously developed will then be checked against these data to assess its suitability in detecting and identifying faults.

From the numerical point of view, a numerical comparison of the yearly performance of heat pumps working with R290 and R410A was made. The R290 heat pump considered in the analysis is an indirect-type one, i.e., a heat pump in which the evaporator is fed with a brine, which, in turn, is heated by environmental air, whereas both direct and indirect systems are considered with R410A. Figure 3-24 shows the layouts of the two (three) heat pumps considered.

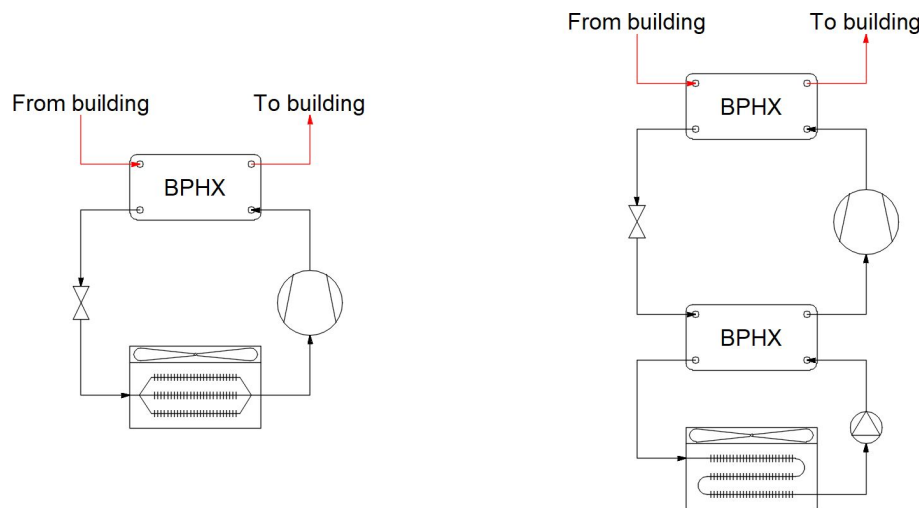

Figure 3-24 – Layout of the direct system (left) and indirect system.

A simulation tool for each configuration was built with a bottom-up approach, i.e., connecting the sub-models developed for each component of the heat pump. A 140 m² two story house located in Milan and with a nominal heating load equal to 6340 W was considered as end-user for the case study. The results show that the performance of the three heat pumps alone (indirect R410A, direct R410A, and indirect R290) is very similar since a reduction in the SCOP of around 3% is found passing from direct R410A system to indirect ones. However, a significant difference arises when the consumptions related to the auxiliaries and the defrosting cycles are taken into consideration. Indeed, the SCOP of the overall system is around 26% lower for the indirect heat pumps with respect to the direct one as the result of the strong increase in the fan and pump consumption in the indirect systems. Nevertheless, the calculation of the TEWI index shows that the indirect heat pump working with R290 significantly benefits from the low GWP of this refrigerant since its TEWI is around 5% lower than that of the direct expansion, R410A system despite the better energy performance of the latter.

Lastly, at the end of September, a new research project about natural refrigerants has started. The project is named “Glide4Heat” and is aimed at analysing the performance of heat pumps using carbon dioxide and hydrocarbon mixtures. The first results are expected in 2024.

3.4.4 Summary

This report briefly summarizes the activities carried out during the 5th year of Annex 54 in Italy.

Since the Italian team consists of three different research groups, the document reports the results of each of them in a dedicated section.

Below is the publication record for 2023:

- Colombo, L.P.M., Frigerio, D., Lucchini, A., Molinaroli, L., 2023. Experimental assessment of the use of R515B as R1234ze(E) alternative in a small water-to-water heat pump. 26th International Congress of Refrigeration (ICR2023), Paris, France, 21-25 August 2023.



Annex 54, Heat pump systems with low-GWP refrigerants

- Conte R., Azzolin M., Bernardinello S., Del Col D., 2023. Experimental investigation of large scroll compressors working with six low-GWP refrigerants, *Thermal Science and Engineering Progress*, Vol. 44, 102043.
- Conte R., Zanetti E., Azzolin M., De Gioia Carabellese C., Calabrese L., Del Col D., Seasonal performance of a CO₂ dual source heat pump for residential applications, paper 0664, 26th International Congress of Refrigeration, Parigi, FR, August 21-25, 2023.
- Conte R., Azzolin M., Bernardinello S., Del Col D., Experimental study of low-GWP refrigerants in a vapor compression system: performance and compressor efficiencies, paper 0640, 26th International Congress of Refrigeration, Parigi, FR, August 21-25, 2023.
- Croci, N., Fusaro, M., Molinaroli, L., 2023. Numerical comparison of the yearly performance of an indirect vapour compression heat pump working with R290 with R410A systems. 14th IEA Heat Pump Conference (HPC2023), Chicago, Illinois, USA, 15-18 May 2023.
- D'Ignazi, C., Bongiorno, C., Molinaroli, L., 2023. Comparison between different refrigerant charge level predictive methods in a water-to-water heat pump. 26th International Congress of Refrigeration (ICR2023), Paris, France, 21-25 August 2023.
- Fedele, L., Trini Castelli, S., Ielpo, P., Zilio, C., Bobbo, S., 2023. The environmental impact of HFOs from TEWI to PFAS. A review. 26th International Congress of Refrigeration (ICR2023), Paris, France, August 21-25, 2023
- Lombardo, G., Menegazzo, D., Scattolini, M., Ferrarini, G., Bobbo, S., Fedele, L., 2023. Thermal Conductivity Measurements for trans-1,3,3,3-Tetrafluoropropene (R1234ze(E)) in Liquid Phase, 22nd European Conference on Thermophysical Properties (ECTP2023), Venice, Italy, September 10-13, 2023
- Lombardo, G., Menegazzo, D., Wedler, C., Fedele, L., Bobbo, S., Trusler, J.P.M., 2023. Speed of sound measurements and correlation of $\{(1-x)3,3,3\text{-trifluoropropene (HFO-1243zf)} + x 2,3,3,3\text{-tetrafluoropropene (HFO-1234yf)}\}$ with $x = (0.1582, 0.4625, 0.7623)$ at temperatures from 243.15 to 343.15 K and pressures up to 90 MPa, 22nd European Conference on Thermophysical Properties (ECTP2023), Venice, Italy, September 10-13, 2023
- Lombardo, G., Menegazzo, D., Fedele, L., Bobbo, S., Scattolini, M., 2023. Experimental assessment and correlation of the liquid density and saturation pressure of trans 1,2 Dichloroethene (R1130(E)). 26th International Congress of Refrigeration (ICR2023), Paris, France, August 21-25, 2023
- Mattiuzzo N., Azzolin M., Berto A., Bortolin S., Del Col D., 2023. Condensation heat transfer and pressure drop of R1234yf/HFC mixtures inside small diameter channels, *International Journal of Thermal Sciences*, Vol. 189, 108258.
- Mattiuzzo N., Azzolin M., Berto A., Bortolin S., Del Col D., Condensation heat transfer of R513A and R516A in a small diameter channel: heat transfer coefficient and flow pattern, 26th International Congress of Refrigeration, Parigi, FR, August 21-25, 2023. DOI: 10.18462/iir.icr.2023.0576
- Menegazzo, D., Lombardo, G., Bobbo, S., Fedele, L., 2023. Isothermal (vapour + liquid) equilibrium measurements and correlation of the binary mixture $\{3,3,3\text{-trifluoropropene (R1243zf)} + \text{isobutane (R600a)}\}$ at temperatures from 283.15 to 323.15 K, 22nd European Conference on Thermophysical Properties (ECTP2023), Venice, Italy, September 10-13, 2023
- Zanetti E., Azzolin M., Conte R., Giroto S., Del Col D., CO₂ dual source solar assisted heat pump with PV-T evaporators: performance and control of low pressure, paper 0641, 26th International Congress of Refrigeration, Parigi, FR, August 21-25, 2023.



- Zanetti E., Bordignon S., Conte R., Bisi A., Azzolin M., Zarrella A., 2023. Experimental and numerical analysis of a CO₂ dual-source heat pump with PVT evaporators for residential heating applications, Applied Thermal Engineering, Vol. 233, 121165, <https://doi.org/10.1016/j.applthermaleng.2023.121165>

3.4.5 Highlights of the most significant accomplishments during the entire Annex 54 period

The most important accomplished is listed as bullets shown below in three aspects:

3.4.5.1 Thermodynamic properties of low GWP refrigerants

- Measurements of VLE for the binary mixture R32+R1234yf.
- Measurements of the thermal conductivity of R1234ze(E).
- Measurements of the saturated vapor pressure for the refrigerant R1130(E) in the range of temperatures between 283 K and 353 K, with a step of 2 K, for a total of 36 points.
- Measurements of the compressed liquid density for R1130(E) in the range of temperatures between 283 K and 423 K, with a step of 20 K, for a total of 8 isotherms, and pressures from saturation up to 35 MPa.
- Measurements of the VLE for the mixture R1243zf+R1234yf at isothermal conditions in the range of temperatures between 283 K and 323 K with steps of 10 K, for a total number of 5 isotherms and 40 (p, T, x, y). The binary interaction parameter in a Helmholtz free energy fundamental EoS has been regressed on the base of these data.
- Measurements of VLE of the binary mixtures R600a+R1234yf and R600a+R1234zf in the range of temperatures between 283.15 K and 323.15 K.
- Systematic literature analysis has been performed to evaluate the availability of experimental data for the main thermophysical properties of the hydrofluoroolefins (HFOs) identified as potential low GWP substitutes for the present high GWP refrigerants (HFCs). 21 HFOs and HCFOs have been investigated. Main results: only 4 fluids have been fully investigated in the literature (R1234yf, R1234ze(E), R1233zd(E), R1243zf), while other 4 (R1234ze(Z), R1336mzz(Z), R1224yd(Z), R1336mzz(E)) have been almost completely characterized; for all the other 13 fluids considered in the analysis, the data available are still scarce and lot of experimental work is still required to obtain the required knowledge. Some of the fluids considered can be applied in heat pump applications (e.g., R1234yf, R1234ze(E), R1234ze(Z), R1233zd(E), R1224yd(Z)), but in general, it will be necessary to mix them with other compounds to obtain suitable thermodynamic properties.

3.4.5.2 Heat transfer with low-GWP refrigerant mixtures

- As a general trend, the diameter of pipes used in heat exchangers is decreasing. For example, in finned-tube coils heat exchangers, diameters around 5 mm are often employed. Therefore, it is important to extend available databases encompassing conditions that include pure fluids, mixtures, and small-diameter channels. These data can be used for the assessment of heat transfer correlations.
- Heat transfer coefficients (HTC) have been measured during condensation inside a 0.96 mm diameter channel with a binary mixture made of R32 and R1234ze(E) (0.748/0.251 by mass composition). A comparison between the condensation performance of the blend and its pure fluids R32 and R1234ze(E) has been made, considering exergy losses.
- Condensation tests have been performed with R1234ze(E) and non-flammable binary mixtures R450A (R1234ze(E)/R134a at 58.0/42.0% by mass) and R515B (R1234ze(E)/ R227ea at 91.1/8.9% by mass) inside two channels with an inner diameter equal to 3.38 mm and 0.96



mm. Flow pattern visualizations were recorded in the 3.38 mm inner diameter tube. The prediction accuracy of condensation heat transfer and two-phase pressure drop models has been assessed against the experimental results.

- Condensation heat transfer, flow pattern transitions and two-phase frictional pressure drop have been investigated with azeotropic mixtures R513A (R1234yf/R134a 56/44% by mass) and R516A (R1234yf/R152a/R134a 77.5/14/8.5% by mass) inside two horizontal channels with 0.96 mm and 3.38 mm internal diameter. Tests at low mass fluxes ($G < 100 \text{ kg m}^{-2} \text{ s}^{-1}$) have been conducted with the aim to better investigate the condensation heat transfer at such experimental conditions, which are frequently experienced in heat pumps when working under partial loads.
- HTC have been measured during flow boiling of ternary non-azeotropic mixtures inside two horizontal smooth tubes of 8.0 mm and 0.96 mm inner diameter. The experimental tests were performed with mixtures R455A (R32/R1234yf/R744 at 21.5/75.5/3% by mass) and R452B (R32/R1234yf/R125 at 67/26/7% by mass), displaying respectively a temperature glide of about 11 K and 1 K in the present tests. The effects of vapour quality, saturation pressure, heat flux, mass velocity and channel diameter on the heat transfer coefficient of the mixtures have been investigated. Models developed for pure fluids, which generally overestimate the heat transfer performance of the blends and do not account for the penalization due to the mass diffusion effects, must be corrected to take in consideration the additional mass transfer resistance.

3.4.5.3 Heat pump

- Selection of the most promising substitutes for R134a and R410A in geothermal heat pumps. Main results: (i) within high pressure fluids, R454B resulted to be the most promising substitute for R410A in all the analyzed cycle; (ii) within the low-pressure fluids, the most efficient fluid resulted to be R516A (+10% COP with reference to R134a); (iii) within ultra-low GWP fluids, the most efficient fluid is R600a. However, several other fluids showed similar performance, with COP or EER penalization of only 2-3%; (iv) R600a and R290 are classified in category 3 (ASHRAE classification) in terms of flammability (very flammable); however, all the other selected fluids are weakly flammable (L2). It is then probable that in any case, safety measures will have to be taken for their application; (v) while the development of the pure compounds (R600a, R290, R1234yf, and R1234ze(E)) is widespread, the mixtures, even those labeled by ASHRAE, look still under experimental study.
- Solar-assisted heat pump working with CO_2 . There are two types of solar-assisted heat pumps (SAHPs): indirect solar-assisted heat pumps (IDX-SAHP), where a secondary fluid is heated up by solar collectors and then sent to the evaporator, and direct solar-assisted heat pumps (DX-SAHPs), where the solar collectors act as the evaporator. However, a solar evaporator is not able to absorb enough energy in the case of low or absent solar irradiance, and thus, a dual-source heat pump working both with solar and air sources can be used to guarantee the operation of the heat pump regardless of the presence of solar irradiance. The use of natural fluids, such as CO_2 , is increasingly growing. Starting from this background, a dual-source transcritical CO_2 heat pump that features hybrid photovoltaic-thermal (PVT) collectors as evaporators has been studied at the University of Padova. The heat pump can work in two different modes using alternatively air or solar radiation as thermal sources. In air-source mode, a conventional finned coil heat exchanger is used as the evaporator whereas, in solar-source mode, an innovative solar hybrid collector (photovoltaic-thermal) is used. The evaporators of the heat pump can work under two operative modes, dry expansion and flooded evaporation. A numerical heat pump model has been developed and implemented as



Annex 54, Heat pump systems with low-GWP refrigerants

- a TRNSYS type for dynamic simulations of the system. The model has been validated with continuous measurements during the heat pump operation in solar and air modes. The proposed model can be used for performing seasonal simulations of a heat pump.
- Dual source (air/ground) heat pumps. The combined use of air or ground as a heat source/sink can be a strategy to improve the efficiency of heat pumps at lower costs because the length of the borehole heat exchangers can be reduced. A heat pump prototype working with R32 that combines the following characteristics has been investigated: the heat pump can work with air or ground as a heat source/sink, and it can operate with a traditional finned coil heat exchanger or with a minichannel heat exchanger. A mathematical model of the heat pump has been developed, allowing us to predict the performance of the heat pump when considering different refrigerants. Numerical simulations are important tools for the assessment of exploiting geothermal energy in heat pump applications. They can be used to evaluate the performance of the system, the long-term production scenarios, and the sustainability of the geothermal reservoir. A mathematical model of the dual-source heat pump has been developed in MATLAB® environment. The dynamic numerical simulator FEFLOW®, based on the finite element method, has been used to simulate the behavior of the geothermal reservoir. This methodological approach is useful to evaluate the performance of the coupled system in the long term, and it is important for understanding the advantages and limits of the dual-source heat pump in assuring sustainability over time and avoiding the depletion of geothermal resources.
 - Refrigerant mass distribution in an invertible air-to-water heat pump. Refrigerant mass distribution measurements have been carried out in an R32 invertible air-to-water heat pump. Experimental tests have been performed using the quick-closing valves technique to isolate the charge within the components of the system. A mathematical model has been developed to predict the refrigerant charge in the heat exchangers of the heat pump.
 - Experimental analysis of several low-GWP alternatives to R134a. Refrigerants studied: R1234yf, R1234ze(E), R450A, R513A and R515B. Main results: R1234yf, R450A, and R513A lead to a capacity in the range 95%-99%, whereas with R1234ze(E) and R515B, the capacity reduction is in the range 77%-80%. The COP lies in the range 93%-99% with R1234yf or R513A, in the range 98%-100% with R1234ze(E) or R450A, and in the range 103%-105% with R515B.
 - When a liquid receiver is installed in the heat pump, in the event of a leakage and depending on the amount of refrigerant that leaks out of the heat pump there exist three different zones in which all the heat pump parameters (COP, heating capacity, operating pressures and expansion valve opening) exhibit peculiar trends with the charge decrease: (i) subcooling sensitivity zone: zone in which the subcooling reduces rapidly as the charge reduces; (ii) constant parameters zone: zone in which all the parameters of the heat pump do not change with the charge reduction and (iii) compressor failure risk zone: zone in which the expansion valve is not able anymore to control the refrigerant superheating at evaporator outlet (compressor suction) which becomes very high. The extension of these zones is determined by the size of the liquid receiver that is installed in the heat pump: the larger this component, the wider the zone 2.
 - Through a yearly simulation, it is found that the SCOP of an indirect expansion R290 heat pump is lower than that of a direct expansion heat pump working with R410A by around 26%, but the TEWI of the former is 3% lower than that of the latter despite the lower energy performance.



3.4.6 Potential tasks for a follow-on Annex.

An Annex about natural refrigerants should be interesting since, in Europe, the new F-Gas regulation bans the use of synthetic refrigerants in some applications.

To reduce the environmental impact of the heat pump during its entire lifespan, we should guarantee that any leakage (direct impact) or performance reduction (indirect impact) should be immediately identified. So, an Annex about Fault Detection and Diagnosis (FDD) techniques is welcome.

3.5 Overall Conclusions

In the Annex, broad-spectrum research activities have been conducted on low-GWP refrigerants from both fundamental and applied research perspectives. Several low-GWP refrigerants, both natural and synthetic, have been screened to generate knowledge about their performance, aiding in the decision-making process for selecting refrigerants for the next generation of heat-pumping systems.

The main findings of the activities are summarized as follows:

- New alternative refrigerants: R454B and R600a proved to be promising alternatives both in computer simulations and within real heat pump systems and are worth further investigation.
- To find non-flammable (A1) alternatives to improve the cycle efficiency and the volumetric cooling capacity, mixtures of HFOs (e.g., R1234yf and R1234ze(E)) and HFCs have been considered. Condensation heat transfer, flow pattern transitions, and two-phase frictional pressure drop have been investigated. When considering non-azeotropic mixtures, models developed for pure fluids must be corrected to account for mass diffusion effects. A comparison of the condensation performance of the different fluids must be done accounting for both heat transfer and pressure drop.
- Heat pump water heater applications: R32 and R290 are viable choices. From a safety perspective, it has been proven that these systems can be manufactured with a charge lower than the maximum allowable threshold value set by current standards.
- Small-medium capacity heat pumps for residential applications: again, R32 and R290 should be the preferred options from both energy efficiency and environmental perspectives.
- Medium-large capacity heat pumps for residential applications: R513A and R1234ze(E) should be the most likely alternatives, depending on the compressor technology used.
- The use of CO₂ as refrigerant in heat pump applications is very promising. One of the main advantages is the possibility of providing a high temperature lift between water inlet and outlet when using a transcritical cycle (e.g. for domestic hot water production). Integrating renewables and heat pumps becomes crucial. However, a solar evaporator is not able to absorb enough energy in the case of low solar irradiance and thus a dual source heat pump working both with solar and air source has been considered. The key innovation lies in the combined operation of two evaporators, a finned-coil and a PV-T (photovoltaic-thermal) collector, enabling selection between air and solar energy or their simultaneous use.
- The combined use of air and ground as heat source can be a strategy to improve the efficiency of heat pumps. Numerical simulations have been used to evaluate the performance of the system, the long-term production scenarios and the sustainability of the geothermal reservoir.



Annex 54, Heat pump systems with low-GWP refrigerants

A mathematical model of the heat pump has been developed in MATLAB®, and the numerical simulator FEFLOW® has been used to simulate the behavior of the geothermal reservoir.

Overall, for any traditional, old, high-GWP refrigerant considered, it is challenging to find a one-to-one low-GWP alternative. Instead, multiple options are available, and the final choice should consider not only thermodynamic properties but also safety aspects, environmental metrics (TEWI or LCA), and cost of the heat supplied (LCOH).



Heat Pump Centre
c/o RISE - Research Institutes of Sweden
PO Box 857
SE-501 15 BORÅS
Sweden
Tel: +46 10 516 53 42
E-mail: hpc@heatpumpcentre.org

www.heatpumpingtechnologies.org

Report no. HPT-AN54-4