



Annex 34

Thermally Driven Heat Pumps for Heating and Cooling

Final Report

Operating Agent: Germany



Published by

IEA Heat Pump Centre
Box 857, SE-501 15 Borås
Sweden
Phone: +46 10 16 55 12
Fax: +46 33 13 19 79

Legal Notice

Neither the IEA Heat Pump Centre nor any person acting on its behalf: (a) makes any warranty or representation, express or implied, with respect to the information contained in this report; or (b) assumes liabilities with respect to the use of, or damages, resulting from the use of this information. Reference herein to any specific commercial product, process, or service by trade name, trademark, manufacturer, or otherwise, does not necessarily constitute or imply its endorsement recommendation or favouring. The views and opinions of authors expressed herein do not necessarily state or reflect those of the IEA Heat Pump Centre, or any of its employees. The information herein is presented in the authors' own words.

© IEA Heat Pump Centre

All rights reserved. No part of this publication may be reproduced, stored in a retrieval system, or transmitted in any form or by any means, electronic, mechanical, photocopying, recording or otherwise, without prior permission of the IEA Heat Pump Centre, Borås, Sweden.

Production

IEA Heat Pump Centre, Borås, Sweden

ISBN 978-91-87461-60-6
Report No. HPP-AN34-1

Preface

This project was carried out within the Heat Pump Programme, HPP which is an Implementing agreement within the International Energy Agency, IEA.

The IEA

The IEA was established in 1974 within the framework of the Organization for Economic Cooperation and Development (OECD) to implement an International Energy Programme. A basic aim of the IEA is to foster cooperation among the IEA participating countries to increase energy security through energy conservation, development of alternative energy sources, new energy technology and research and development (R&D). This is achieved, in part, through a programme of energy technology and R&D collaboration, currently within the framework of over 40 Implementing Agreements.

The IEA Heat Pump Programme

The Implementing Agreement for a Programme of Research, Development, Demonstration and Promotion of Heat Pumping Technologies (IA) forms the legal basis for the IEA Heat Pump Programme. Signatories of the IA are either governments or organizations designated by their respective governments to conduct programmes in the field of energy conservation.

Under the IA collaborative tasks or “Annexes” in the field of heat pumps are undertaken. These tasks are conducted on a cost-sharing and/or task-sharing basis by the participating countries. An Annex is in general coordinated by one country which acts as the Operating Agent (manager). Annexes have specific topics and work plans and operate for a specified period, usually several years. The objectives vary from information exchange to the development and implementation of technology. This report presents the results of one Annex. The Programme is governed by an Executive Committee, which monitors existing projects and identifies new areas where collaborative effort may be beneficial.

The IEA Heat Pump Centre

A central role within the IEA Heat Pump Programme is played by the IEA Heat Pump Centre (HPC). Consistent with the overall objective of the IA the HPC seeks to advance and disseminate knowledge about heat pumps, and promote their use wherever appropriate. Activities of the HPC include the production of a quarterly newsletter and the webpage, the organization of workshops, an inquiry service and a promotion programme. The HPC also publishes selected results from other Annexes, and this publication is one result of this activity.

For further information about the IEA Heat Pump Programme and for inquiries on heat pump issues in general contact the IEA Heat Pump Centre at the following address:

IEA Heat Pump Centre
Box 857
SE-501 15 BORÅS
Sweden
Phone: +46 10 16 55 12
Fax: +46 33 13 19 79

Annex 34 – Final Report

Submitted by
Fraunhofer-Institute for Solar Energy Systems ISE
Heidenhofstr. 2
79110 Freiburg, Germany

Contributors list (alphabetical order):

J. Albers (TU Berlin), M. Aprile (POLIMI), E.-J. Bakker (ECN), S. Chmielewski (Viessmann), R. Critoph (Univ. of Warwick), B. Dawoud (Viessmann), A. De Luca (EURAC), J. Demierre (EPFL), R. Fedrizzi (EURAC), A. Frazzica (ITAE), A. Freni (ITAE), G. Földner (ISE), R. Gavriiliuc (UTCB), K. R. Gluesenkamp (UoM), C. Hennrich (TU Berlin), M. Helm (ZAE), S. K. Henninger (ISE), U. Jakob (Solarnext), M. Kegel (NRCan), O. Kotenko (TU Graz), A. Kühn (TU Berlin), I. Malenković (AIT), F. Mehling (ISE), P. Melograno (EURAC), S. J. Metcalf (Univ. of Warwick), W. Mittelbach (SorTech), H. Moser (TU Graz), S. R. Nordtvedt (IFE), S. Petersen (TU Berlin), S. Pezzutto (EURAC), J. Promelle (GDF SUEZ), R. Radermacher (UoM), M. Radspieler (ZAE), G. Restuccia (ITAE CNR), R. Rieberer (TU Graz), M. Schicktanz (ISE), P. Schossig (ISE), J. R. Santiago (EURAC), C. Schweigler (ZAE), R. Sunye (NRCan), K. T. Witte (ISE), C. Wuschig (ZAE), P. Zachmeier (ZAE), F. Ziegler (TU Berlin)

Table of Content

Summary and Outlook	11
1 Introduction to Thermally Driven Heat Pumps	13
1.1 The Scope of the Annex	14
1.2 State of the Art.....	16
1.2.1 Background.....	16
1.2.2 Liquid absorption and solid adsorption closed-cycles	17
1.2.3 The diffusion of thermally driven heat pumps	23
1.2.4 Absorption heat pump cycle	25
1.2.5 Adsorption cycle.....	29
1.2.6 Alternative TDHP Technologies	32
1.3 Market overview.....	32
1.3.1 Global demand for heating and cooling.....	33
1.3.2 Global energy demand for heating and cooling – possible development trends 33	
1.3.3 Germany – taking climate change into account.....	35
1.3.4 Heat pump market	36
1.3.4.1 Conventional heat pumps in Europe – current situation.....	36
1.3.4.2 Conventional heat pumps in other regions – current situation	38
1.3.4.3 Gas Heat Pump Market – current situation.....	38
1.3.4.4 Gas Heat Pump Market - perspectives.....	39
1.3.4.5 Other thermal Heat Pump Market – current situation	42
1.3.5 Air conditioning market.....	43
1.3.5.1 Conventional air conditioning market – current situation	43
1.3.5.2 Solar thermal cooling market – current situation	44
2 Performance Evaluation	45
2.1 Standards and Definitions.....	45
2.1.1 Definition of the analysis criteria	46
2.1.2 Assessment of the documents.....	49
2.1.3 Dissemination within Annex 34	50
2.1.4 Recommendations for future work	51
2.2 Definition of Performance Figures for TDHP and Systems Including TDHP	52
2.2.1 Introduction	52
2.2.2 Definition of Applications	52
2.2.2.1 Framework conditions	52
2.2.2.2 System classification	53

2.2.2.3	Flow charts	54
2.2.2.3.1	Reference TDHP system	55
2.2.2.3.2	Direct fired combined heating and cooling (DFCH&C)	56
2.2.3	Definition of performance figures	57
2.2.3.1	Definition of system boundaries.....	57
2.2.3.2	Performance figures.....	58
2.2.3.3	Example: Direct fired combined heating and cooling system (.....	60
3	Apparatus Technology	63
3.1	Adsorption components.....	64
3.1.1	Overview on adsorber developments	64
3.1.2	Adsorber characterization.....	66
3.1.2.1	Samples preparation	66
3.1.2.2	Setup for adsorption kinetic measurements.....	67
3.1.2.3	Results and discussion.....	70
3.1.3	Evaporator developments	74
3.2	Characterisation of adsorption materials	76
3.2.1	General overview.....	76
3.2.2	Proposed procedure	77
3.2.3	Results	78
3.2.3.1	Comparison on Silica Gel 127 B	78
3.2.3.2	Comparison on SAPO-34	80
3.2.3.3	Influence of different measurement conditions	81
3.2.4	Transformation	81
3.2.4.1	Dubinin Transformation	82
3.2.4.1	Other Transformations.....	84
3.2.5	Conclusions	85
3.3	New developments on adsorption materials and material database	85
3.4	New developments in absorption technology.....	86
3.4.1	Ionic liquids as new working pairs	86
3.4.1.1	Research at TU Berlin	87
3.4.1.2	Research at ZAE Bayern	88
3.4.1.3	Research at TU Graz.....	89
3.4.2	High Temperature Regenerator	90
3.4.3	Inert gas analysis in absorption TDHPs.....	91
3.4.4	Optimized dimensioning of heat exchanger surfaces	92
4	System Technology	93

4.1	Introduction	93
4.2	Max System representation	93
4.3	Schematic Hydronic Representation	95
4.3.1	Basic system topology	96
4.3.2	Composition of generic systems	97
4.3.3	Driving heat input at highest temperature level.....	98
4.3.4	Heat output at intermediate temperature level: Heat rejection (waste heat) or useful heat output for space heating or other heat utilization	102
4.3.5	Heat input at low temperature level: Generation of cooling effect or uptake of ambient heat for heat pump operation	105
4.3.6	Selection guide	108
4.3.7	Outlook and dissemination	112
4.4	Energy Flows Representation.....	112
4.4.1	Source Sink Approach.....	112
4.4.2	Energy Flow Chart	114
4.4.3	Data Acquisition Tables	115
5	Demonstration plants	117
5.1	Template of Demonstration Plant.....	117
5.1.1	Application	118
5.1.2	TDHP and Energy System.....	118
5.1.3	Control Strategies	120
5.1.4	Scheme and Representation.....	120
5.1.5	Monitoring data and Performance evaluation.....	122
5.2	Demonstration Plants.....	123
6	Appendix	125
6.1	National projects and contributions.....	125
6.2	Meetings	128
6.3	Other publications	128
7	Literature	130

List of figures

Fig. 1-1: Structure of Annex 34.....	15
Fig. 1-2: Ideal thermodynamic limitations	16
Fig. 1-3: Simple water - LiBr absorption cycle schematic	17
Fig. 1-4: Simple adsorption schematic with heat recovery phase	18
Fig. 1-5: Picture of Mycom adsorption chiller (100 kW chiller).....	18
Fig. 1-6: Photo of a falling film absorber through a gauge glass (© TU Berlin, Germany)....	19
Fig. 1-7: Modes of falling films on horizontal tubes (Hu und Jacobi 1998, p. 323)(Hu 1998)19	19
Fig. 1-8: Adsorbers developed at University of Warwick, UK	20
Fig. 1-9: Adsorbers developed at ITAE, Italy	21
Fig. 1-10: Double effect absorption machine	22
Fig. 1-11: Thermal wave adsorption heat pump patented by Shelton. - Wave Air Corporation, 1993. Solid-Sorption Gas Heat Pump: Technology and market description, internal report, August 1993.	22
Fig. 1-12: Compression (left) and absorption (right) heat pump cycle	25
Fig. 1-13: Absorption heat pump cycle in the $\ln p$ - $1/T$ -diagram.....	26
Fig. 1-14: Double-/Single-effect absorption cycle in the $\ln p$ - $1/T$ -diagram (Riepl, Gurtner et al. 2011).....	27
Fig. 1-15: Double-/Single-effect absorption solar thermal plant for flexible heating and cooling. (Riepl, Gurtner et al. 2011).....	27
Fig. 1-16: Absorption heat pump cycle in the $\ln p$ - $1/T$ -diagram of water/LiBr (Feuerecker 1994).....	28
Fig. 1-17: Absorption heat pump cycle in the $\ln p$ - $1/T$ -diagram of NH ₃ /water(Ziegler 1984)	29
Fig. 1-18: Dühring-Diagram for Silica-Gel 127B. © Fraunhofer ISE.....	31
Fig. 1-19: Classification of the global heating and cooling market. World map of Köppen- Geiger climate classification (University of Melbourne, 2010) as basis and category groups according to (Dieryckx 2011).....	33
Fig. 1-20: Development of heat pump sales in Europe from 2005 to 2010. Source : EHPA. .	37
Fig. 1-21: Sales by category in 2010 (*includes sales of reversible air/air heat pumps). Source : EHPA.	38
Fig. 1-22: Amount of natural gas per final energy consumption of private household in 2008 according to Bohnenschäfer.	39
Fig. 1-23: Goals to apply environmental heat as well as geothermal due to the use of heat pumps according to Bohnenschäfer.....	40

Fig. 1-24: Natural gas consumption by country in 2009. Source: FhG-ISE according to (Portal 2009).....	41
Fig. 1-25: Yearly installed facilities (Germany) in 1000 units per year and dwelling units per year for the oil boilers as well as million m ² /year for solar collectors (Source: FhG-ISE with data according to table of (Kleemann 2010)).....	42
Fig. 2-1: Classification of TDHP systems.....	54
Fig. 2-2: Reference system for applications including TDHP: Modified SHC Task 38 representation (above), “Square View” (below).....	55
Fig. 2-3 Direct fired TDHP system for combined heating and cooling; modified SHC Task 38 representation.....	56
Fig. 2-4 Direct fired TDHP system for combined heating and cooling; “Square View” representation.....	57
Fig. 2-5 Overview of the key performance figures for TDHP units and systems.....	59
Fig. 2-6 System boundaries and energy flows of a DFHC&C-system.....	60
Fig. 3-1: Different adsorber concepts.....	64
Fig. 3-2: Different evolution steps of the performance enhancement in adsorber development: Packed-bed heat exchanger (left), binder based dip-coated lamella heat exchanger (centre) and direct crystallisation connection of the sorbent (right) on 3D-metal structure heat exchanger. Source (Schossig P. 2011).....	65
Fig. 3-3: Preparation of the coated samples: dip coating phase and consolidate layer after calcination.....	67
Fig. 3-4: Scheme of the entire kinetic measurement setup.....	68
Fig. 3-5: Integration of the sample inside the testing chamber.....	69
Fig. 3-6: Dynamic evolution of the absolute uptake of the four tested samples: in the upper part after desorption against the vacuum pump, in the lower part after desorption against the condenser @ 30°C.....	70
Fig. 3-7: Dynamic evolution of the relative uptake of the four tested samples: in the upper part after desorption against the vacuum pump, in the lower part after desorption against the condenser @ 30°C.....	71
Fig. 3-8: Dynamic evolution of the surface temperature of the four tested samples: in the upper part after desorption against the vacuum pump, in the lower part after desorption against the condenser @ 30°C.....	71
Fig. 3-9: Comparison of pool boiling at a low filling level (left) versus falling film evaporation (right) as investigated in the SORCOOL project at Fraunhofer ISE.....	74
Fig. 3-10: Enhancement technics to increase the outer heat transfer of an immersed tube and a cut-out with pictures of nucleate pool boiling at a 3D-metal structure manufactured by Fraunhofer Institute for Manufacturing Technology and Advanced Materials (IFAM) on the	

left hand as well as high performance evaporation tubes from the manufacturers Wieland Werke AG (top right) and La Mont Kessel GmbH & Co. KG with a surface treatment by MiCryon Technik GmbH (bottom right).....	75
Fig. 3-11: Influencing factors for thermal analysis of the adsorption characteristics.....	77
Fig. 3-12: Proposed measurement procedure, including sample pre-treatment and the first isobaric step.....	78
Fig. 3-13: Comparison of isobar adsorption measurements for Silica Gel 127 B at 1.2 kPa. .	79
Fig. 3-14: <i>Comparison of isobar adsorption and desorption measurements for Silica Gel 127 B at 5.6 kPa.</i>	79
Fig. 3-15: Comparison of 1.1 kPa and 1.2 kPa adsorption/desorption isobars on a SAPO-34 sample. ISE measurements have been performed in an open flow system.	80
Fig. 3-16: Comparison of measurements for the SAPO-34 sample with different equipment and procedures.....	81
Fig. 3-17: Transformation according to D-A equation of the equilibrium points for water/Silica Gel.	83
Fig. 3-18: Transformation of equilibrium point for water /SAPO-34 according to Dubinin's theory.....	84
Fig. 3-19: Photograph of the test rig at TU Berlin.....	87
Fig. 3-20: Test results of water/LiBr and water/IL working pairs.....	88
Fig. 3-21: Photograph of the test rig at ZAE Bayern.....	89
Fig. 3-22: Simulation results of the COP for $t_{ABS}/t_{EVA}=25/5^{\circ}\text{C}$, $35/5^{\circ}\text{C}$ and $45/5^{\circ}\text{C}$ of $\text{NH}_3/[\text{bmim}][\text{PF}_6]$ AHP-processes without rectification column in comparison to a conventional $\text{NH}_3/\text{H}_2\text{O}$ AHP-process with rectification column depending on the generator outlet temperature.....	90
Fig. 3-23: Schematic drawing of the thermosiphon cycle test rig with indicated instrumentation.....	92
Fig. 4-1: Max-system representation from IEA-SHC Task 38.....	94
Fig. 4-2: Max system representation for a heating and cooling, direct and/or indirect fired application	95
Fig. 4-3: Example of indirect fired heating and cooling application.....	95
Fig. 4-4: Basic solar cooling system: Thermally driven chiller coupled to solar thermal system, cooling water loop, and chilled water loop.	97
Fig. 4-5: Generic system: standardized system topology with placeholders for the integration of optional system components.	98
Fig. 4-6: Indirect (left) and direct fired (right) sorption heat pump.....	99
Fig. 4-7: Solar sub-system: options for the solar collector.....	99

Fig. 4-8: Solar sub-system: heat exchanger for separation of primary and secondary solar loop.....	100
Fig. 4-9: Solar sub-system: options for the heat storage and domestic hot water preparation.	100
Fig. 4-10: Driving heat sources: Boiler, District heating, and Heat from co-generation systems.	102
Fig. 4-11: Solar sub-system: options for the integration of the backup-heater.....	102
Fig. 4-12: Heat rejection sub-system: open and closed wet and dry cooling towers and alternative heat sinks.	103
Fig. 4-13: Heat rejection sub-system: auxiliary coolers.	104
Fig. 4-14: Heat rejection sub-system: optional heat exchangers for separation of thermally driven chiller, auxiliary cooler and main cooler.....	104
Fig. 4-15: Heating appliances for utilization of the heat output of the sorption heat pump at intermediate temperature level for space heating.	105
Fig. 4-16: Chilled water sub-system: Room-side installations for the transfer of the cooling effect.....	105
Fig. 4-17: Chilled water sub-system: Options for the distribution of the chilled water.	106
Fig. 4-18: Chilled water sub-system: Chilled water storage and latent cold storage (PCM, phase change material).	107
Fig. 4-19: Chilled water sub-system: Integration of a compression chiller or a ground water well as backup cooling source.....	107
Fig. 4-20: Heat sources for heat pump operation: Air-heat exchanger, boreholes geothermal collectors (ground heat exchanger) or ground water well,	108
Fig. 4-21: Source-Sink table.....	112
Fig. 4-22: Close-up of the source-sink table.....	113
Fig. 4-23: Reduced source-sink table	114
Fig. 4-24: Energy Flow Chart. Method with permission of IEA- SHC Task 44 -HPP Annex 38, 2011	115
Fig. 4-25: Thermal energy data acquisition table.....	116
Fig. 4-26: Electric energy data acquisition table	116
Fig. 4-27: Performance figures calculation table.....	117
Fig. 5-12: Templates classified in Mode of operation.....	117
Fig. 5-13: Templates classified in Heat pump/Chiller size.....	117
Fig. 5-1: Sheet containing the main features of the plant.....	118
Fig. 5-2: Description of the system on the basis of the TDHP evaporator. <i>Summer period:</i> Distribution System.....	119

Fig. 5-3: Description of the system on the basis of the TDHP evaporator <i>winter period</i> : Heat Sources	120
Fig. 5-4: Hydronic representation of a plant installed in the brewery's storehouse in Graz (A) - <i>summer season</i> : Cooling and DHW functional scheme Source: TU Graz.....	121
Fig. 5-5: Hydronic representation of a plant installed in the brewery's storehouse in Graz (A) - <i>winter season</i> : Heating and DHW functional scheme. Source: TU Graz.....	122
Fig. 5-6: Example of Tabular representation. <i>Winter season</i> : Heating and DHW functional scheme of a plant installed in the brewery's storehouse in Graz (A) - Source: TU Graz.....	123
Fig. 5-7: Example of Energy Flow Chart. <i>Winter season</i> : Heating and DHW functional scheme of a plant installed in the brewery's storehouse in Graz (A) - Source: TU Graz.....	123
Two of the TDHPs are directly fired and 11 are indirectly fired (see Fig. 5–8). About the last, five are solar cooling applications, four are driven by a CHP unit and three are district heat driven (one is driven by solar thermal and CHP unit, see Fig. 5–9).....	124
Of the 13 TDHPs one is used in heating mode in winter and in cooling mode in summer. Eight are only used for cooling and four are only used for heating. None is used for heating and cooling simultaneously (see Fig. 5–10). Two thirds Fig. 5-12). Nine of the TDHPs are small scaled. They have a cooling or heating capacity lower than 70 kW. Four have a higher cooling or heating capacity up to 700 kW (see 5–11). Fig. 5-13).	125
Fig. 5-12: Templates classified in Mode of operation.....	125
Fig. 5-13: Templates classified in Heat pump/Chiller size.....	125

List of tables

Table 1-1: Available thermally driven heat pumps	23
Table 1-2 - Overview on machine costs (only) per technology (February 2011).....	44
Table 1-3 –Technology and cost characteristic of heat pumps for heating and cooling in single-family dwellings, 2007 [20].....	45
Table 2-1: Overview of analysed standards and guidelines	48
Table 3-1: Basic steps of the isothermal measurements.....	69
Table 3-2: Characteristics of the different tested samples.....	70
Table 3-3: Characteristic times obtained on the tested samples.....	72
Table 3-4: Specific Cooling Power [W/g] evaluated for the tested configuration (desorption against condenser).	73
Table 3-5: Geometrical characteristics of the reference HEX.....	73
Table 3-6: Estimated volumetric and specific cooling power for the four AdHEX configurations.....	73
Table 4-1: Selection guide for components of the generic system.....	109
Table 6-1: Funding list for Annex 34	126
Table 6-2: List of Annex 34 meetings.....	128

SUMMARY AND OUTLOOK

Thermally driven heat pumps (TDHPs) for heating and cooling are now a well-established technology. Machines for industrial high power application are available on the market as well as for small domestic systems. In national and international institutions first standards and regulations are available which are addressing aspects of quality assurance.

However, the technology suffers from varied obstacles. Among these are technological difficulties and still a lag of standards. Within this Annex both aspects are examined. An introduction to the two major representative technologies, namely absorption and adsorption type TDHPs is given. Those two techniques show some similarities in terms of operation and design of some components but also have some differences and specific advantages and disadvantages. A detailed understanding of these technologies is therefore mandatory and an introduction to the underlying working principle is given in this report. Besides sorption technologies other thermally driven processes are also described.

Within this annex a market analysis was performed which consists of two parts a global point of view and a country specific point of view. As shown in this report the analysis on global level points out that there is an increasing demand for heating and cooling worldwide, therefore showing the high potential of the technology. Climate change and an increasing demand of comfort and more people being able to afford air conditioning, leads to an increase of heating and cooling demand. With this the general market situation the specialty market for TDHPs is increasing. In contrast, higher standards in building construction and insulation technology are reducing the heating and cooling market.

It is a matter of the country-specific situation, the climate and the policy to allow TDHPs to enter the market. The partners of Annex 34 therefore analysed the boundary conditions and legislative framework for their countries. These reports are available for the participants.

Putting the focus to the technological challenges, it turns out that on system level the TDHP technology offers a great variety of different hydronic options and concepts. This was again shown within this report as none of the demonstration plants is similar to another. The variety offers opportunities and threads for this technology. On the one hand efficient solutions for a specific problem can be found, working best at the given boundary conditions. On the other hand, the variety leads to a lag of comparability and standardization which is, however, required for a successful market penetration. Installers need guidelines to set up such a system, the installation must be simple and errors should be avoided easily. However, configuration errors and inefficient control strategies are often reported. This stresses the need for packages solutions and standards. Also customers ask for simple and understandable key figures to compare TDHPs among each other and against other technologies. With this Annex, we take a big step forward in standardising performance figures. A collection of the most important definitions in current standards is given in this report.

Moreover, a common language and a performance figure rating system is proposed for TDHP systems, which includes:

- a universal nomenclature to label each energy flow within a cooling or heating system
- a definition of key figures on different boundary levels like on component level, on system level and for different modes of operation
- a standardized graphical representation for the energy flows
- a standardized graphical representation for the hydronic connection of a TDHP system

Consequently, the proposed procedures are applied within this report. The results can be found in section 5 and in the nine separate reports about selected demonstration plants, which come as an appendix with this final report.

The proposed next steps to push standardisation are as follows: We need national and international norms to claim the standards as binding. This will allow us to have a labelling system which helps customers realize the benefits of TDHP systems compared to other technological options.

The cooperation between the partners within the Annex 34 framework offered great opportunities to exchange knowledge. This included also the developments of components within the TDHP machines. It was possible to evaluate the measurement procedures for adsorption heat exchangers of different laboratories in different countries regarding their similarities and differences. Thereby, credibility of the measured physical parameters from different partners could be confirmed. A common procedure for the description of the physical properties of different adsorption materials was worked out.

Moreover, an internal material database has been created by the Annex 34 participants. The work on this data base will be continued in future tasks.

1 INTRODUCTION TO THERMALLY DRIVEN HEAT PUMPS

Thinking about heat pumping processes nowadays is usually associated with electrically driven vapour compression machines providing either heat or cold for the desired purpose. Consequently vapour compression machines became a synonym for heat pumps as well as for chillers. However, this was not always the case. In the beginning of refrigeration and heat pumping in the early 1800's, sorption processes had been paid the same attention as vapour compression for heat transformation. Some even consider absorption technology as the oldest applied heat transformation process. Nevertheless, novel refrigerants and widely available electricity led to an incredible success story of vapour compression heat pumps and chillers in the 20th Century and thermally driven heat pumps became a niche market.

The present trend of rising electricity prices in combination with environmental considerations may cause a revival of thermally driven heat pumps. Using solar or waste heat as a driving force for chilling processes or gas fired heat pumps instead of condensing gas boilers might lead to significant primary energy savings in the heating and cooling of buildings. Another interesting aspect of thermally driven heat pumps is the use of environmentally harmless refrigerants with a very low Global Warming Potential (GWP). Consequently, more and more thermally driven heat pump products are being launched on the market, especially in the low power range below 50 kW, e.g. applications like gas driven heat pumps for single family houses as well many applications focusing on solar assisted cooling.

This growing market share generates a need for performance evaluation procedures of these technologies, since the existing heat pump and chiller standards are not applicable to thermally driven heat pumps. It is necessary to take the specific characteristics of heat driven machines into account in order to make a useful comparison between different heating and cooling devices.

We are very happy that after four years of the Annex 34 research on thermally driven heat pumps, we can present with this final report the progress of these technologies and future perspectives. Moreover, we hope that these will help to develop the family of heat pumps in order to reach the goal of environmentally friendly heating and cooling in buildings for the future.

1.1 The Scope of the Annex

The goal of this annex was to reduce the environmental impact of heating and cooling by the use of thermally driven heat pumps. It is based on the results of IEA-HPP Annex 24 "Absorption Machines for Heating and Cooling in Future Energy Systems" and was carried out in cooperation with the IEA-SHC task 38 "Solar Air-Conditioning and Refrigeration".

The scope of the work performed in this Annex was on the use of thermally driven heat pumps and chillers in domestic and small commercial buildings and industrial applications, such as:

- ✓ Larger district heating systems (DH) with cooling and/or heat pumping
- ✓ Small thermally driven heat pumps for domestic heating and cooling
- ✓ Small Absorption/Adsorption chillers driven by heat from combined heat and power (CHP) units
- ✓ Small Absorption/Adsorption chillers driven by solar heat
- ✓ Industrial processes using waste heat

In addition analyses of the state of the art technology have been performed and the potential of the technology in specific application areas was evaluated. A major objective of this Annex was the development of means to analyse the technical performance of thermally driven systems and ways to improve the performance and overall economy of these application. Therefore tools which support the implementation and integration of thermally driven heat pumps and heat recovery systems in domestic, small commercial buildings and industrial applications have been evaluated.

The market scope was systems used for heating and cooling purposes in buildings and industrial applications.

The detailed objectives and scopes of the Annex were summarized as follows:

- (a) Quantify the economic, environmental and energy performance of integrated thermally driven heat pumps in cooling and heating systems in a range of climates, countries and applications.
- (b) Examine ways of improving the cost-effectiveness and efficiency of combined thermally driven cooling and heating systems in order to give information on potential applications and markets for users, system designers and equipment manufacturers
- (c) From the objectives mentioned in (a) and (b) identify those areas and applications with:
 - the greatest environmental benefit;
 - the best economics;
 - the greatest market potential ;
 - a good potential to help launch the technology
- (d) Identify market barriers and propose measures to reduce them.

- (e) Carry out and monitor case studies and demonstration projects in order to increase the experience with integrated thermally driven cooling and heating systems and to increase the acceptance in specific market segments of these systems.
- (f) Propose technical procedures to be included in future standards for determination of the COP of thermally driven heat pumps and methods to evaluate primary energy consumption of the systems within this annex.
- (g) Define procedures for measuring physical properties of the active materials in the machines and set up a data base about used materials and working pairs.
- (h) Spread information about thermally driven heat pumps, their applications and performance.

The objectives were grouped into the following task structure and adopted by the partners:

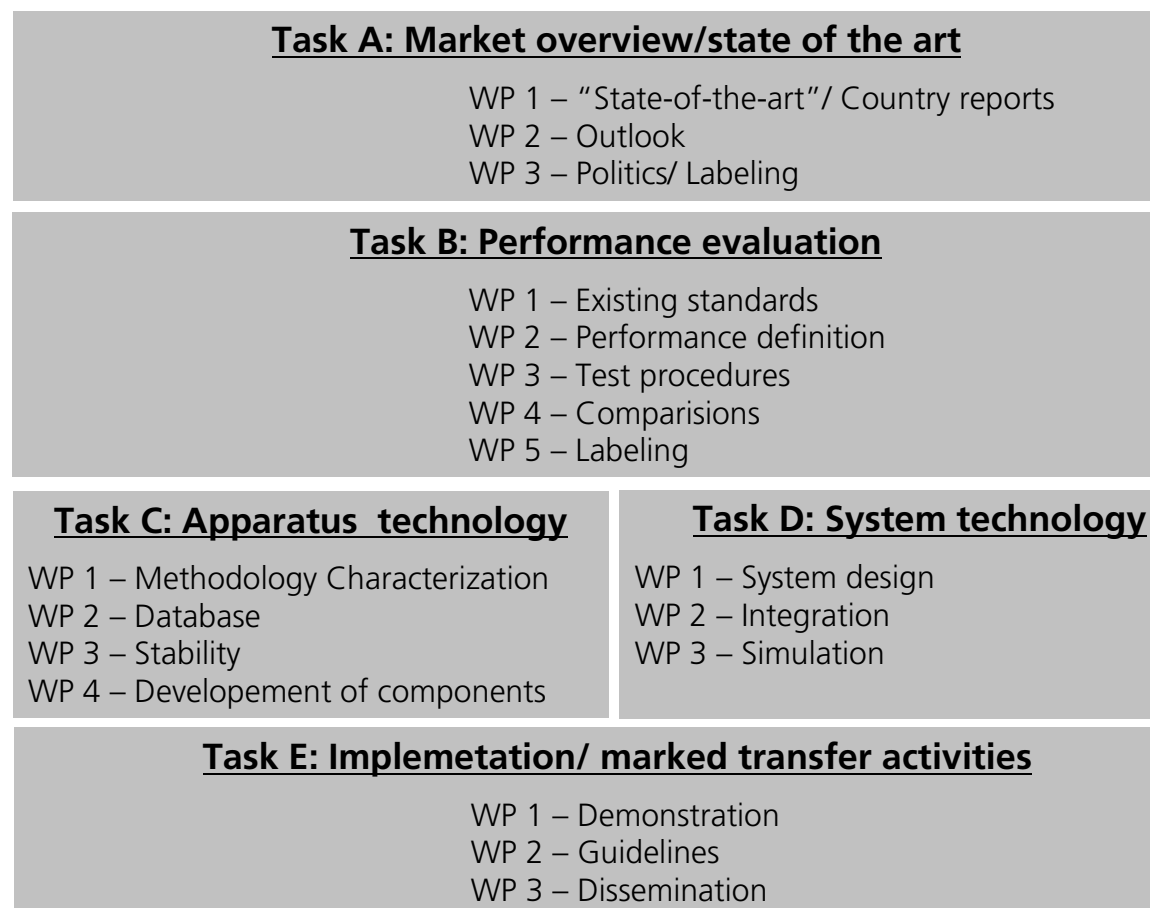

Fig. 1-1: Structure of Annex 34

1.2 State of the Art

1.2.1 Background

Thermally driven heat pumps/air conditioners using environmental friendly refrigerants represent an energy efficient technology. Their use, in comparison with traditional vapour compression systems, can create a benefit in terms of reduction of electricity peak load, mitigation of Global Warming Potential and of primary energy saving, especially when waste heat or solar energy are used as the driving energy.

Basically, a heat-driven heat pump/chiller works at three levels of temperature: the machine is driven by a heat source at high temperature T_h , heat is rejected at medium temperature T_m and extracted at low temperature T_c . The heat rejected at medium temperature is the useful effect provided in heat pumping operation. The cold produced at low temperature is the useful effect provided in chilling mode.

Basic thermodynamics limits performance in the same way as for mechanically driven systems (Fig. 1-2) with COP being a function of the three temperature levels; the upper limit for $T_h = 200^\circ\text{C}$, $T_m = 45^\circ\text{C}$ and $T_c = -5^\circ\text{C}$ would be 2.8 but half the Carnot limit would be typical. Additional discussions of performance limits is provided in (Herold 1996) and (Alefeld 1994).

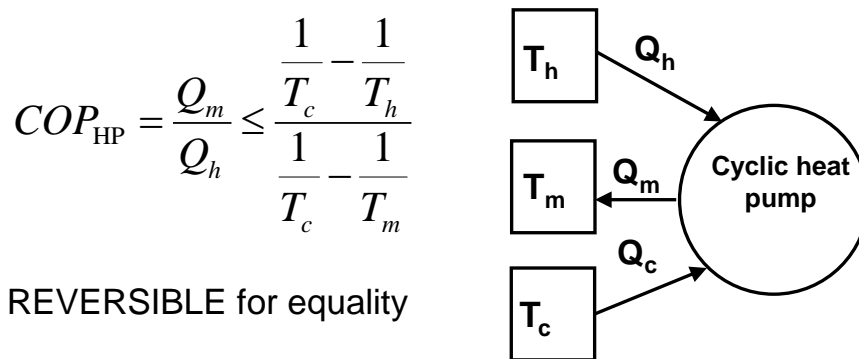

Fig. 1-2: Ideal thermodynamic limitations

The most important representatives of heat-driven cooling systems are absorption and adsorption closed-cycles. Other options are also available and are discussed in section 1.2.6.

Sorption technologies range from small units of 10 kW (or even less) to huge units of a few MW, and may be driven by a large variety of heat sources, including waste or solar heat and direct combustion of fuel. Another advantage is the utilization of a “thermal compressor” instead of a mechanical compressor, ensuring silent and quite operation, which is particularly attractive for application in buildings like residential houses, museums, theatres, etc.

An overview of thermally driven technologies, including open sorption, closed sorption and thermo-mechanical cycles, and their application to micro CHP, is provided in (Critoph and Zhong 2005), (Gluesenkamp and Rademacher 2011) and (Ziegler 2002). Further details of matching thermally-driven equipment to engine waste heat sources are discussed in (Gluesenkamp in press). Solar cooling options are reviewed in (Hwang, Rademacher et al. 2008).

1.2.2 Liquid absorption and solid adsorption closed-cycles

Both technologies are based on a working pair of a refrigerant and a sorption medium. In absorption devices the refrigerant is absorbed, i.e. dissolved, in the liquid sorption medium changing its concentration. The most common working pairs are Lithium Bromide/Water (

Fig. 1-3) and Ammonia/Water (Critoph and Metcalf 2011). In case of adsorption chillers, the refrigerant is adsorbed in the pores of the solid adsorption medium. The most common working pairs are Zeolite/water, Silica Gel/water (Fig. 1-4), Activated carbon/ammonia, and Activated carbon/methanol (Henninger, Schmidt et al. 2010) (Schickanz, Hugenell et al. 2012). The technologies are thermodynamically similar and have an analogous basic configuration, which consists of four main components: a reactor termed a generator, where the sorbent (liquid or solid) is heated at high temperature; the condenser, where the desorbed refrigerant vapour is condensed into liquid; the evaporator, where the cooling effect is produced; a reactor called ab-/adsorber that receives refrigerant vapour from the evaporator. In the case of liquid absorption machines, a pump is used to continuously circulate the rich solution from the absorber to the generator and the weak solution back to the absorber. The two reactors of a solid adsorption machine operate in counter-phase to ensure continuous useful cooling effect and are alternatively heated for desorption and cooled for adsorption. Unlike an absorption machine, a circulation pump is not required. A more detailed description of the absorption and adsorption cycle is given in section 1.2.4 and 1.2.5.

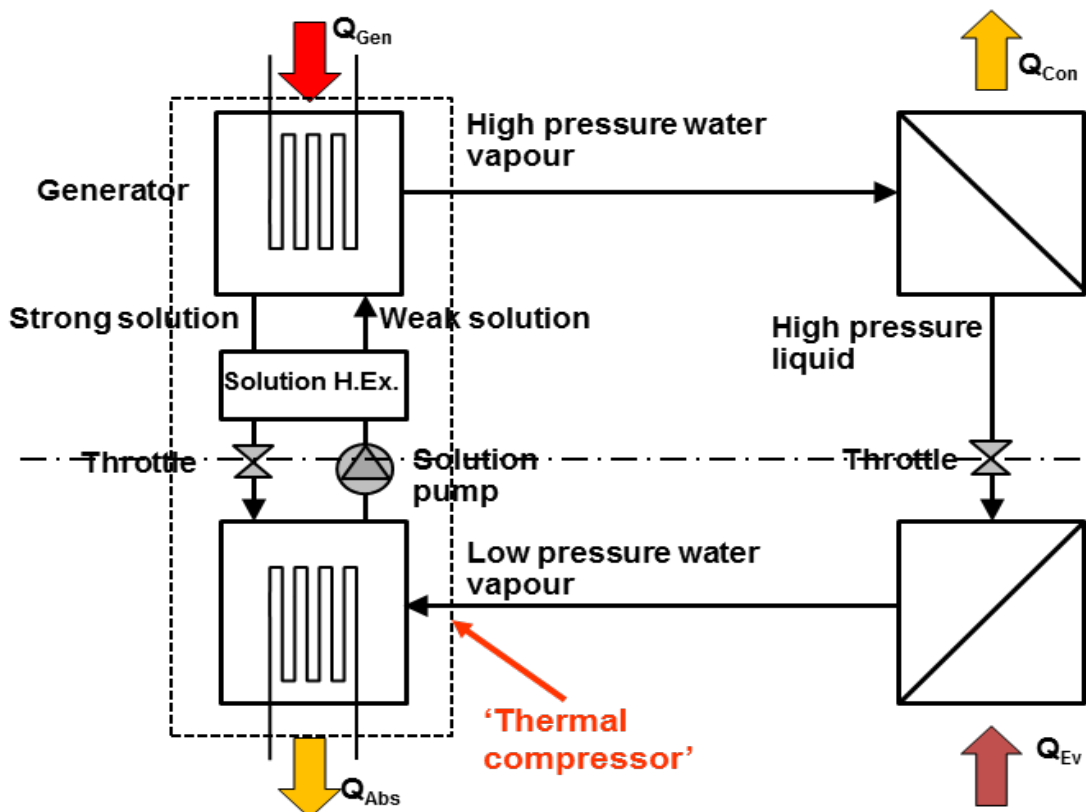

Fig. 1-3: Simple water - LiBr absorption cycle schematic

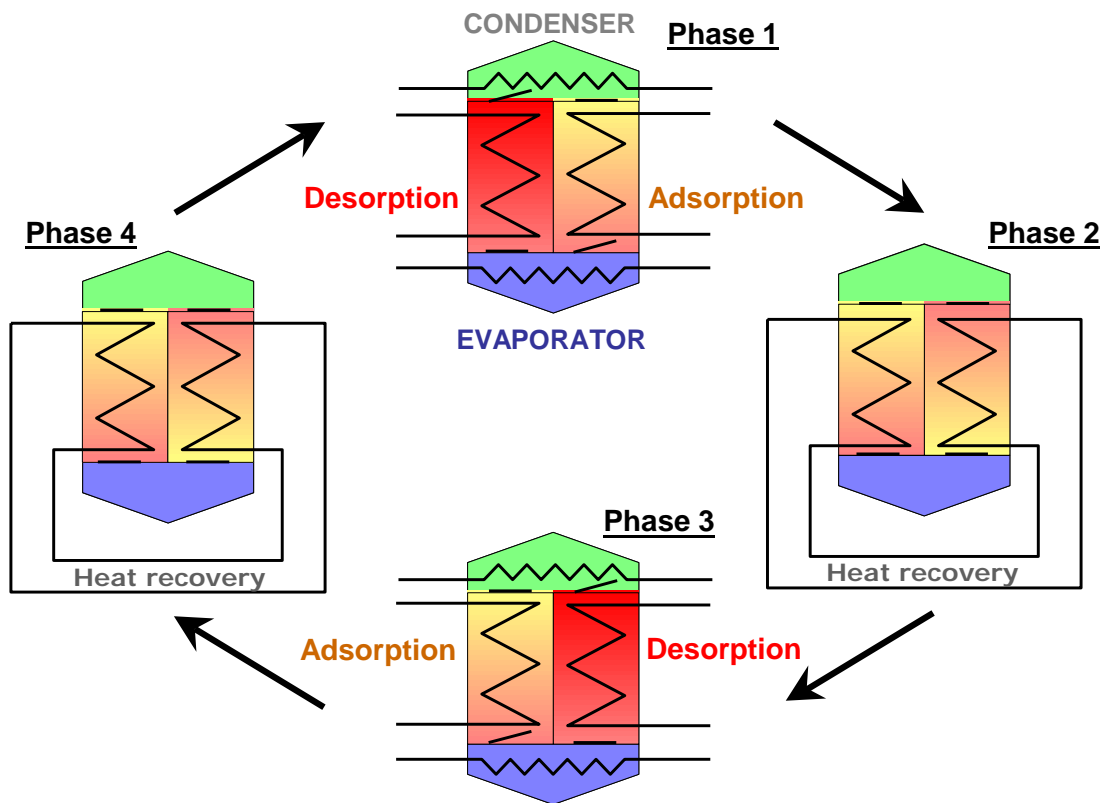

Fig. 1-4: Simple adsorption schematic with heat recovery phase



Fig. 1-5: Picture of Mycom adsorption chiller (100 kW chiller)

The evaporator and condenser have the same function as in mechanical vapour compression cycles and, in the case of high pressure refrigerants such as ammonia can be standard components. Where the refrigerant is water or methanol, specially

designed evaporators and condensers are needed because of the very low density of the refrigerant, particularly in evaporation. Routing the refrigerant through conventional tubes would result in pressure drops resulting in much reduced performance. It is common to house a pool boiling or falling film evaporator or generator in the same vessel as the ab-/adsorber to avoid this.

Liquid absorbers are commonly of the falling film type (see Fig. 1-6).

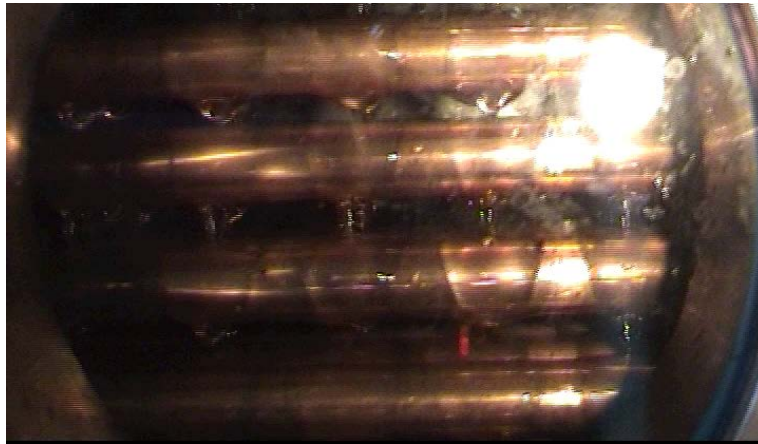

Fig. 1-6: Photo of a falling film absorber through a gauge glass (© TU Berlin, Germany)

(Hu and Jacobi 1996) distinguish three modes of falling films on horizontal tubes. At low Reynolds numbers, there is the formation of individual droplets between the tubes. With increasing Reynolds numbers they coalesce until, finally, a closed film is formed (see Fig. 1-7). In absorption heat pumps, the film Reynolds number usually is low.

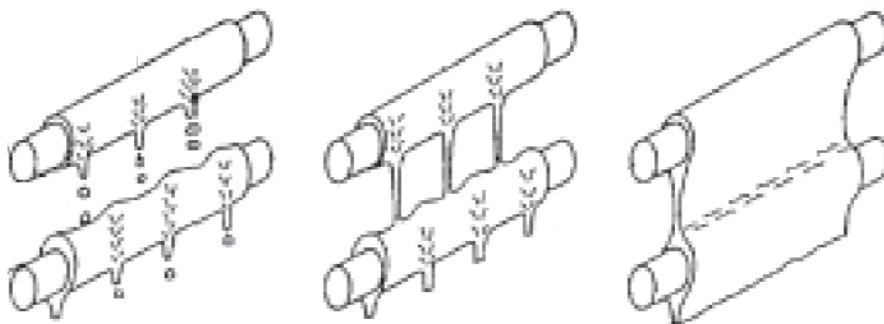

Fig. 1-7: Modes of falling films on horizontal tubes (Hu und Jacobi 1998, p. 323)(Hu 1998)

Typically, the heat exchangers are designed as horizontal tube-bundles or in spiral form. There are some research activities on adiabatic absorbers but they are not used in market available machines. The solution is either sprayed onto the pipes or applied

by special devices to distribute droplets evenly. In some cases the pipes are smooth in others they have a specially shaped structure.

Adsorption generators are very different in that the adsorbent stays within the vessel and must be alternately heated and cooled. Loose packed adsorbents have very low thermal conductivity (c. 0.1 W/mK) and so heat transfer is a major challenge. Attempting to improve heat transfer with, for example, large numbers of fins can be counterproductive, because of the thermal mass of the fins and vessel. When the whole assembly is heated and cooled through one cycle, a certain fixed amount of heat is pumped from a low to a high level. The heat that enters the adsorbent is useful but the heat that simply raises the temperature of the vessel and fins is wasted. Some of this heat can be recovered but minimising the thermal mass of the container and any inert material that is cycled in temperature is essential. Previous solutions have included lightweight plate fin-tubes, micro channels, micro-tube in shell, finned tubes, etc....

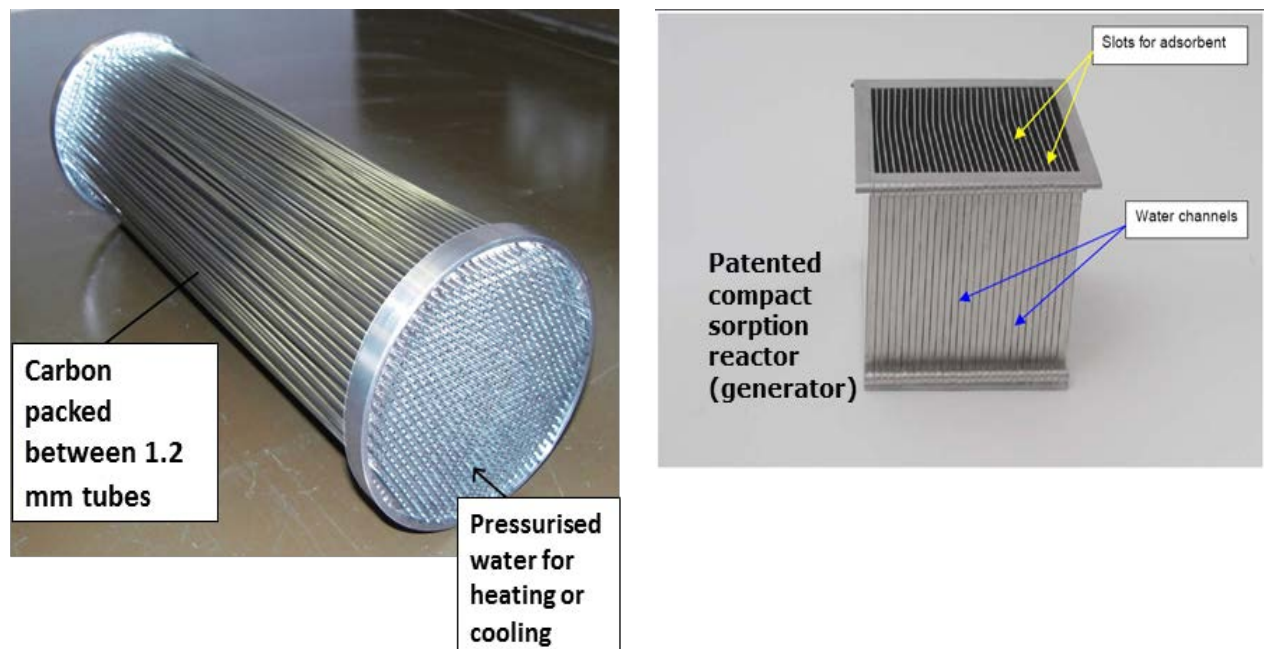

Fig. 1-8: Adsorbers developed at University of Warwick, UK

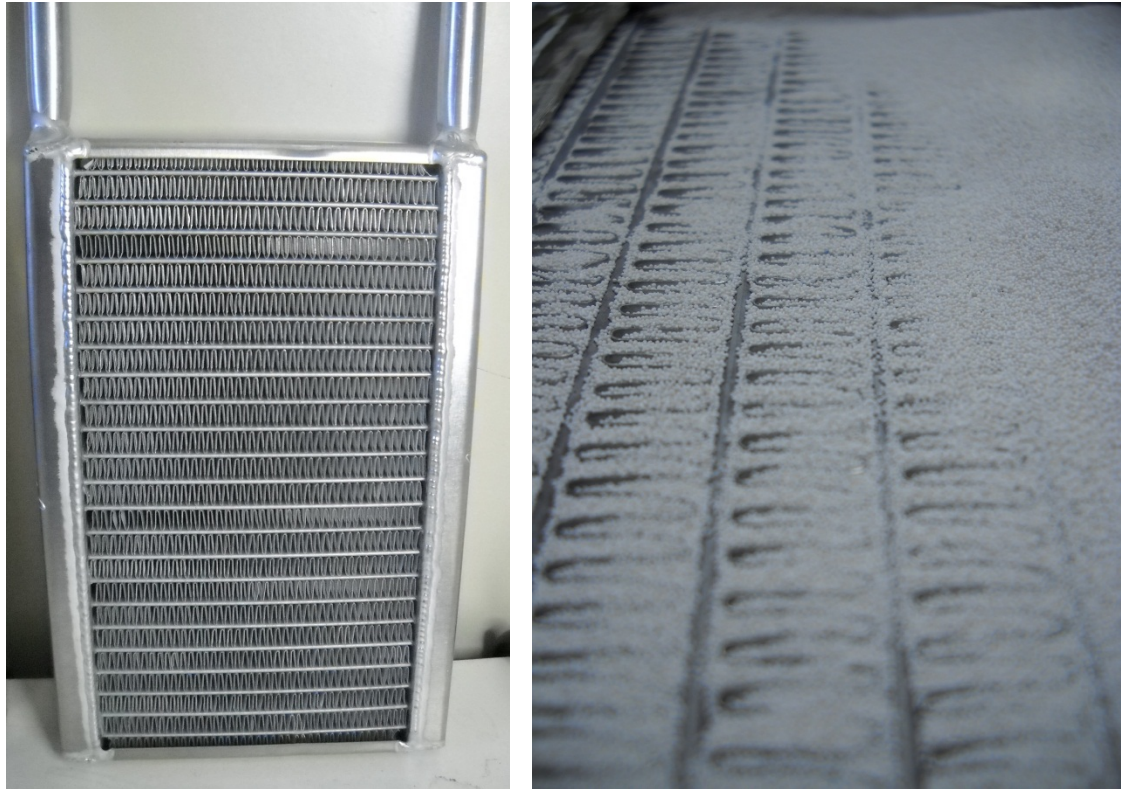

Fig. 1-9: Adsorbers developed at ITAE, Italy

In order to increase the performance of the machines, some more sophisticated configurations have been developed, such as double and triple effect liquid absorption machines and multi-bed (Fig. 1-10) or thermal wave solid adsorption machine (Fig. 1-11). Also combinations of single and double effect chillers are possible. See (Plura, Radspieler et al. 2008) as an example. Such advanced configurations are thermodynamically more efficient but may be driven by a heating source at higher temperature and usually require complex hydronic arrangements and elaborate control strategies.

Another possibility to increase the efficiency of absorption and adsorption TDHPs is to reduce the cooling water outlet temperature. This can be done e.g. by the use of phase changing material to store the colder ambient temperatures from night-time to daytime. Such concepts are investigated by (Hagel, Helm et al. 2011) and (Hiebler, Mehling et al. 2009).

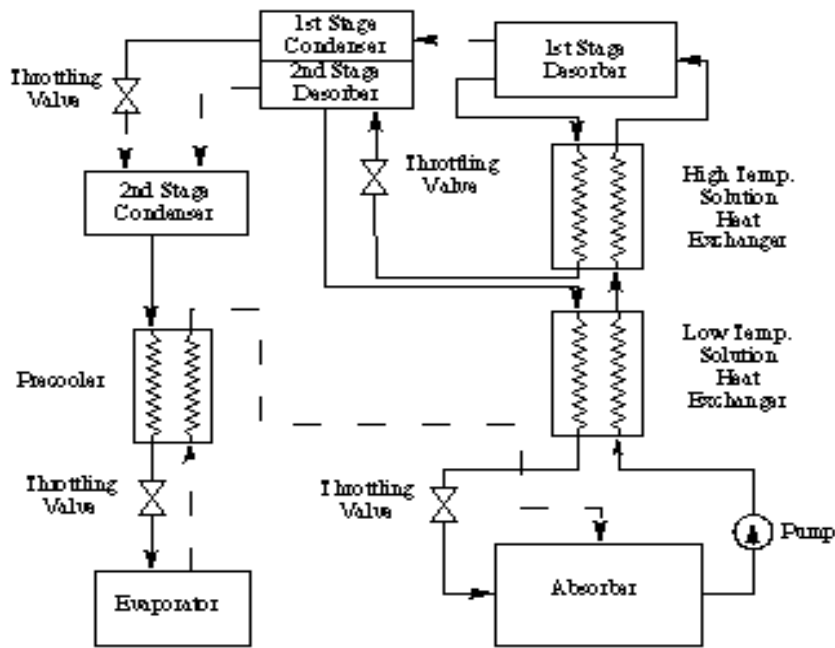

Fig. 1-10: Double effect absorption machine

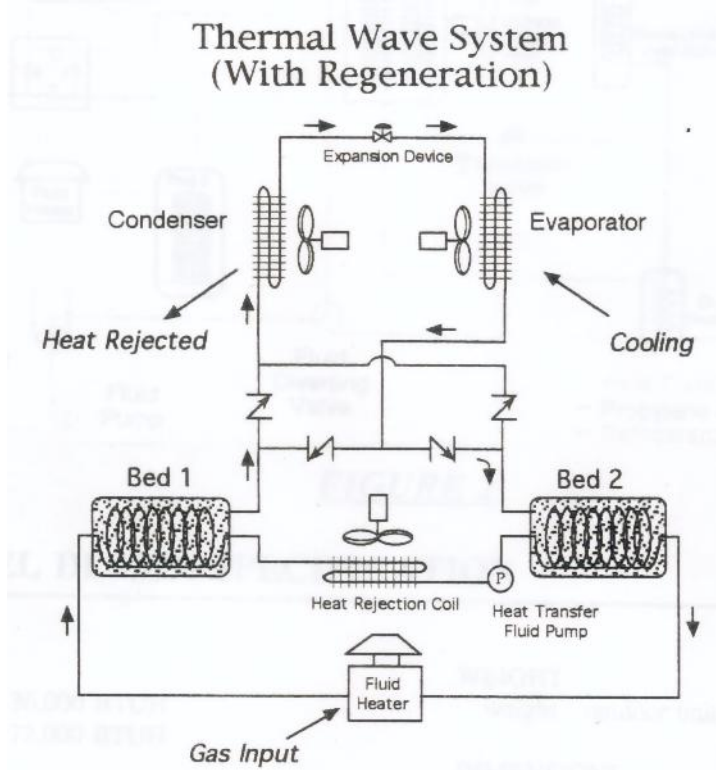

Fig. 1-11: Thermal wave adsorption heat pump patented by Shelton. - Wave Air Corporation, 1993. Solid-Sorption Gas Heat Pump: Technology and market description, internal report, August 1993.

Table 1-1 summarises the technologies, the pairs used and compares the main properties and performance of the most used thermally driven products.

Table 1-1: Available thermally driven heat pumps

Process	Adsorption		Absorption		
	water silica gel	water zeolite	water/LiBr Single-effect	water/LiBr double-effect	ammonia water
Temperature Heat source [°C]	60-90	75-150	75-110	135-200	100-180
Capacity [kW]	7.5-500	7-15	15-12000	200-6000	18-700
COP heat pumping	1.4-1.6	1.3-1.5	1.4-1.6	1.8-2.2	1.4-1.6
COP cooling	0.5-0.7	0.4-0.6	0.6-0.7	0.9-1.3	0.5-0.7

In general, liquid absorption machines can guarantee high COP both for cooling/heat pumping mode. Some practical problems still exist such as crystallization and corrosion problems (LiBr-water) and high energy consumption of the circulation pumps for Ammonia/water machines that require special design. Basic solid adsorption machines without multiple beds etc. have lower thermodynamic efficiency but can be driven by lower driving temperatures, which makes this technology particularly interesting for utilization of low grade waste heat or solar energy. Moreover, operation of a solid sorption machine is not affected by motion, so that another attractive application is the cooling/air conditioning of automobiles or boats.

1.2.3 The diffusion of thermally driven heat pumps

Being extensively studied and developed, absorption chillers/heat pumps are now considered mature technology, resulting in sales of high quality products by several manufacturers. Absorption heat pumps for space heating and cooling are often gas-fired, i.e. are integrated with a gas boiler that produces the driving thermal energy of the sorption heat pump; in this case a good integration of the condensing boiler with the sorption device is needed in order to obtain a globally efficient system.

There are several gas fired absorption heat pumps available on the market, generally considered a good match for in the small-medium capacity range. Among these products, one of the most interesting is based on the ammonia/water pair, and is produced by Robur (Italy). It is integrated with the boiler and is able to supply heat for ambient heating and cooling with a seasonal global performance factor as high as 1.4.

Different lithium bromide/water absorption machines have been available on the market for many years, in single or double effect configuration, and driven by various heat sources (direct fired, hot water, district heat and steam). Triple-effects machines have been developed only as far as pre-commercial prototypes, and require very high driving temperature (>200 °C). Many manufacturers of LiBr/water machines are located in Asia (Sanyo, Yazaki, Broad, LG, Hitachi, etc.) and the United States (Carrier, York, TRANE, etc.). Frequently, LiBr–water absorption chillers are integrated with cogeneration plants or solar-assisted systems. However, in solar applications, a single effect machine typically requires a heat source of about 88 °C or higher, so that expensive evacuated tube collectors must be employed instead of cheaper flat- type collectors.

Solid adsorption systems have been less studied and developed than liquid absorption ones, so that there still exists a wide margin for their development in process optimisation, increase in performance and at the same time reduction of manufacturing costs. Historically, first silica gel/water adsorption chillers, produced by Nishiyodo and Mycom (Japan), appeared in the market in the late 80's. Such chillers, still available on the market, have larger cooling capacities (30-470 kW) and can be efficiently driven by hot water at 60-90 °C, delivering COPs of up to 0.6. Recently, Germany has become the country most active in the development and construction of solid sorption heat pumps/chillers especially for small capacity systems. One of the most interesting properties of solid sorption devices is their ability to maintain good performance even in small capacity systems. This has encouraged a few small German companies (SorTech, Invensor) to produce chillers based on water/silica gel and water/zeolite with cooling capacities starting from 7 and 5 kW respectively.

Furthermore, Viessmann and Vaillant are ready to market a product consisting of a boiler integrated with a solid adsorption heat pump for single apartment heating expected to have a field seasonal heating performance factor higher than 1.2. Viessmann and Vaillant (solid sorption) and Robur (liquid sorption), in collaboration with Ruhrgas and other gas utilities, are participating a very interesting joint project "Gas Heat Pump Initiative (<http://www.IGWP.de>)", whose main aim is to further develop absorption and adsorption heat pump technology to market maturity, through practical laboratory tests and field trials. Other significant contributions in the development of this technology are being made by companies located in China (DY Refrigeration and Jiangsu Shuangliang) and Sorption Energy Ltd. in the United Kingdom.

A special contribution to sorbent materials, has been made by the researchers of Mitsubishi Chemical (Japan), who have developed a new class of adsorbent materials (AQSOA-FAM), specifically designed to be used in adsorption chillers. These new adsorbents, having a crystalline structure, are preferred to the amorphous silica gel and can be regenerated with a thermal source in the range 60-90 °C. Even at this low regeneration temperature, differential loading on the order of 0.2 [$\text{kg}_{\text{water}}/\text{kg}_{\text{adsorbent}}$] can be achieved due to the "s-shaped" isotherm of the material: a large uptake in water occurs over a small change in pressure or temperature.

The University of Maryland (United States) is investigating Mitsubishi Plastic's AQSOA-FAM Z01 zeolite in a 2 kW prototype adsorption chiller utilizing adsorbent-coated fin-and-tube heat exchangers (Gluesenkamp 2011) . The chiller is driven by 70°C waste heat from a micro CHP reciprocating engine. Also in the United States, Power Partners sells Eco-Max adsorption chillers (ECO-MAX 2012) .

1.2.4 Absorption heat pump cycle

Just as in the conventional compression heat pump process, in the absorption heat pump process useful heat is produced by condensation of a refrigerant at high pressure. Prior to that, in the evaporator (E) the refrigerant has been evaporated at low pressure using a low temperature heat source (see Fig. 1-12).

The fundamentals of the absorption heat pump cycle has been well documented in (Herold 1996) and (Alefeld 1994). A discussion of recent trends is provided in (Gluesenkamp, Radermacher et al. 2011).

As essential difference in the absorption heat pump process is that the refrigerant vapour is not compressed by an electrically driven compressor to overcome the pressure difference but pumped in a liquid state. Due to the considerably lower specific volume of liquid compared to vapour refrigerant the electrical energy input required is very small.

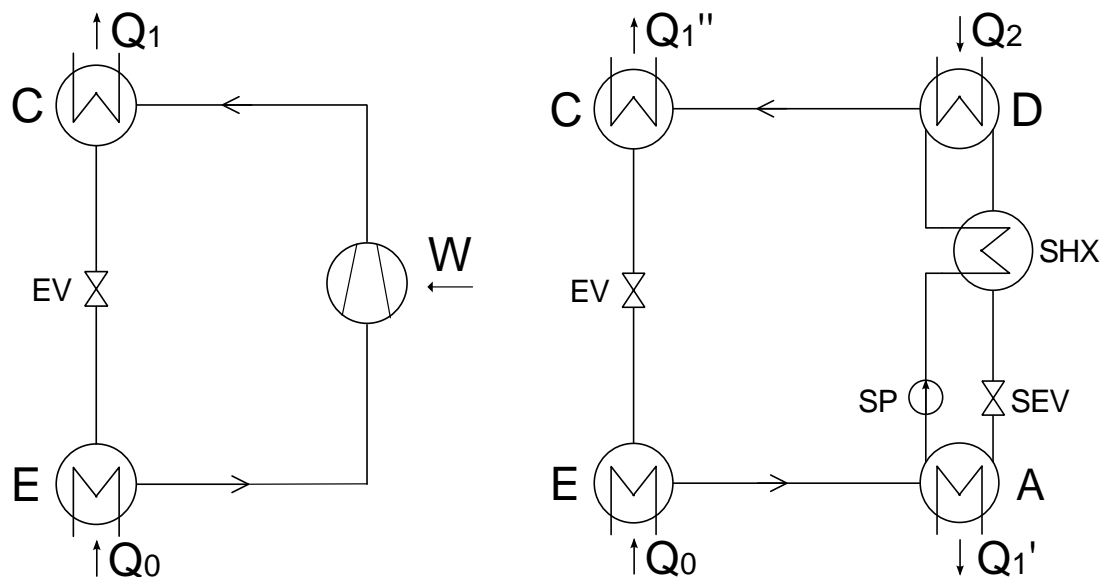

Fig. 1-12: Compression (left) and absorption (right) heat pump cycle

To remove refrigerant vapour from the evaporator, a suitable absorbent liquid is used absorbing the vapour and creating a pressure difference that drive the flow of gas. The affinity of the absorbent for the refrigerant enables it to keep the refrigerant in solution when both evaporator and absorber are at the same pressure but the absorber is at considerably higher temperature. During the absorption process in the absorber (A) heat is generated and has to be released. It can be used for heating purposes in a similar fashion to the condensation heat.

During the absorption process, the absorbent is diluted and has to be regenerated to maintain its absorption capability. The diluted solution is therefore pumped to the higher pressure level into the desorber (D) where heat is supplied to boil off the refrigerant. The vapour refrigerant is condensed in the condenser (C), and throttled to the evaporator pressure, so that the refrigerant cycle can start again. The concentrated solution is also throttled and flows back to the absorber where it can absorb the

vapour refrigerant anew. Another heat exchanger — the so-called solution heat exchanger (SHX) — is used to increase the efficiency of the process by internal heat exchange.

The absorption heat pump cycle is usually displayed in a vapour pressure diagram as in Fig. 1-13, where due to the logarithmic pressure scale and inverse temperature scale the boiling curves are almost straight lines. In this diagram the two pressure levels and the three temperature levels are easily recognizable. x_w and x_s are the absorbent mass fractions of the weak (diluted) and the strong (concentrated) solution. The absorbent mass fraction is defined as ratio of absorbent mass to total mass of solution. Ideally, the absorbent mass fraction of the refrigerant x_R is 0, i.e. there is no absorbent in the refrigerant cycle between condenser and evaporator.

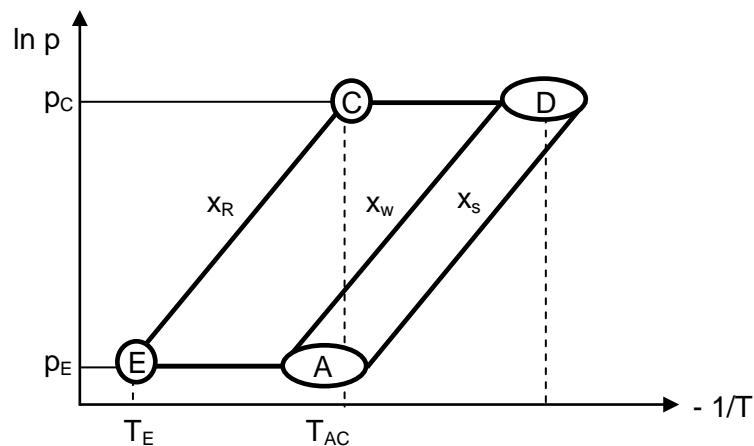

Fig. 1-13: Absorption heat pump cycle in the $\ln p$ - $1/T$ -diagram

The basic cycle described so far is also referred to as single-effect. Another option is the use of Multi-Stage cycles. Multi-Stage absorption cycles increase the efficiency of the heat pump process but require the driving heat to be applied at a higher temperature. The heat of condensation can be used for driving the lower single-stage cycle of the heat pump (see Fig. 1-14). This double usage of the driving heat (exploitation of the high exergetic content of the driving heat) almost doubles the efficiency of the cooling cycle compared to a single-effect heat pump.

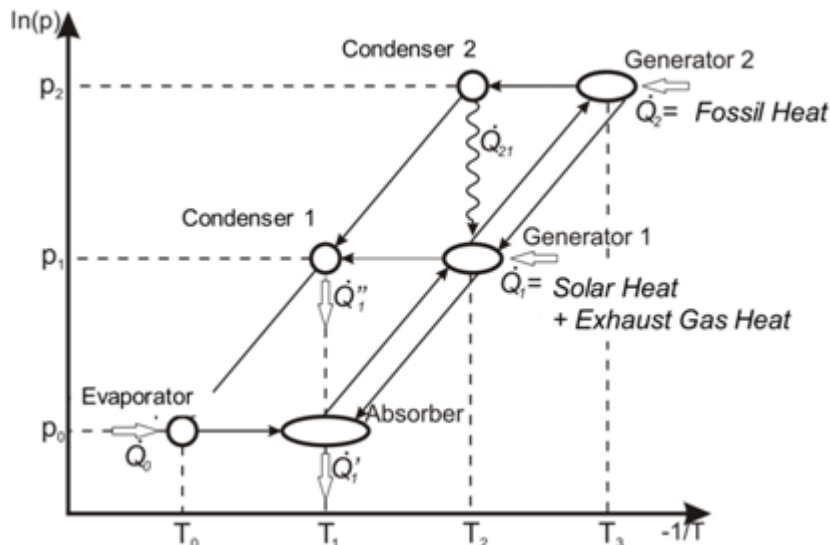

Fig. 1-14: Double-/Single-effect absorption cycle in the $\ln p/-1/T$ -diagram (Riepl, Gurtner et al. 2011)

Such advanced configurations are thermodynamically more efficient but may be driven by a heating source at higher temperature and usually require complex hydronic arrangements and elaborate controls. See Fig. 1-15 for a possible hydronic configuration.

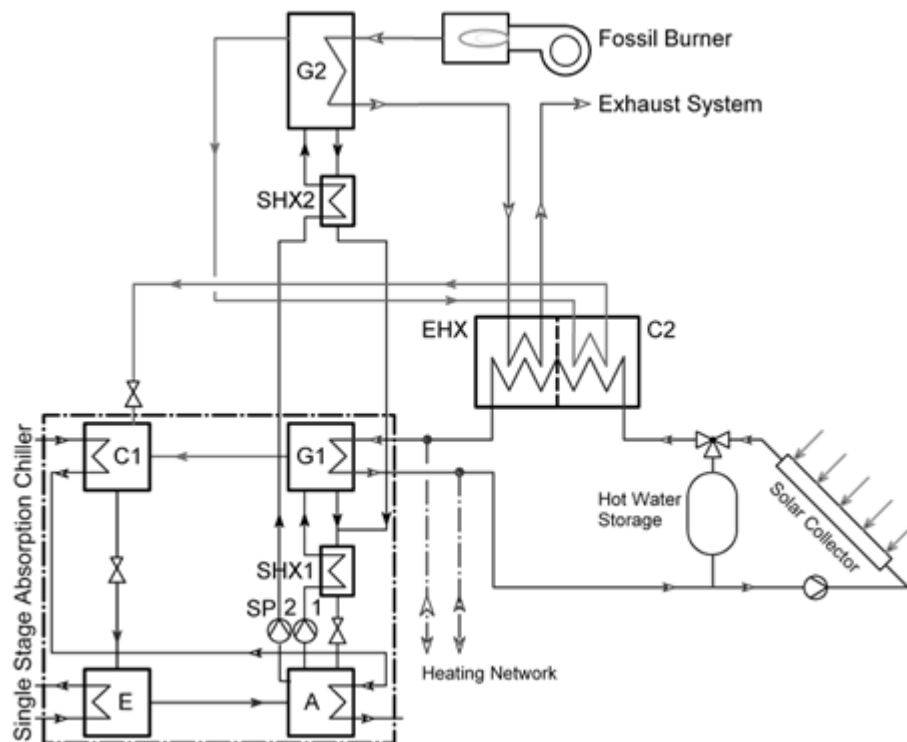

Fig. 1-15: Double-/Single-effect absorption solar thermal plant for flexible heating and cooling. (Riepl, Gurtner et al. 2011)

Although many working pairs for absorption heat pumps and cooling machines have been suggested over the last few decades, only two prevail: water/LiBr and ammonia/water.

Water has an excellent high latent heat, is chemically stable, non-toxic, environmentally-neutral, and economic. A drawback, however, is the low vapour pressure which requires a vacuum tight construction of the vessels. The freezing temperature of 0°C limits the application. However, the depression of the freezing point by adding decreasing substances like salts is possible [Kojima, Kühn, Richter]. Aqueous LiBr solution has a negligible vapour pressure, a low viscosity, and is non-toxic. An unfavourable effect is the formation of crystals at higher absorbent concentration (see crystallization line in Fig. 1-16). This limits the possible temperature lift and therefore, for example, the use as a heat pump in the retrofit market where higher heat output temperatures are required. However, the working pair water/LiBr permits the highest energetic efficiency using simple, well-engineered and compact systems. Reviews of crystallization strategies are addressed in (Wang, Abdelaziz et al. 2011) and (Gluesenkamp, Radermacher et al. 2011), and a strategy utilizing separate sensible and latent cooling is described in (Gluesenkamp, Horvath et al. 2011).

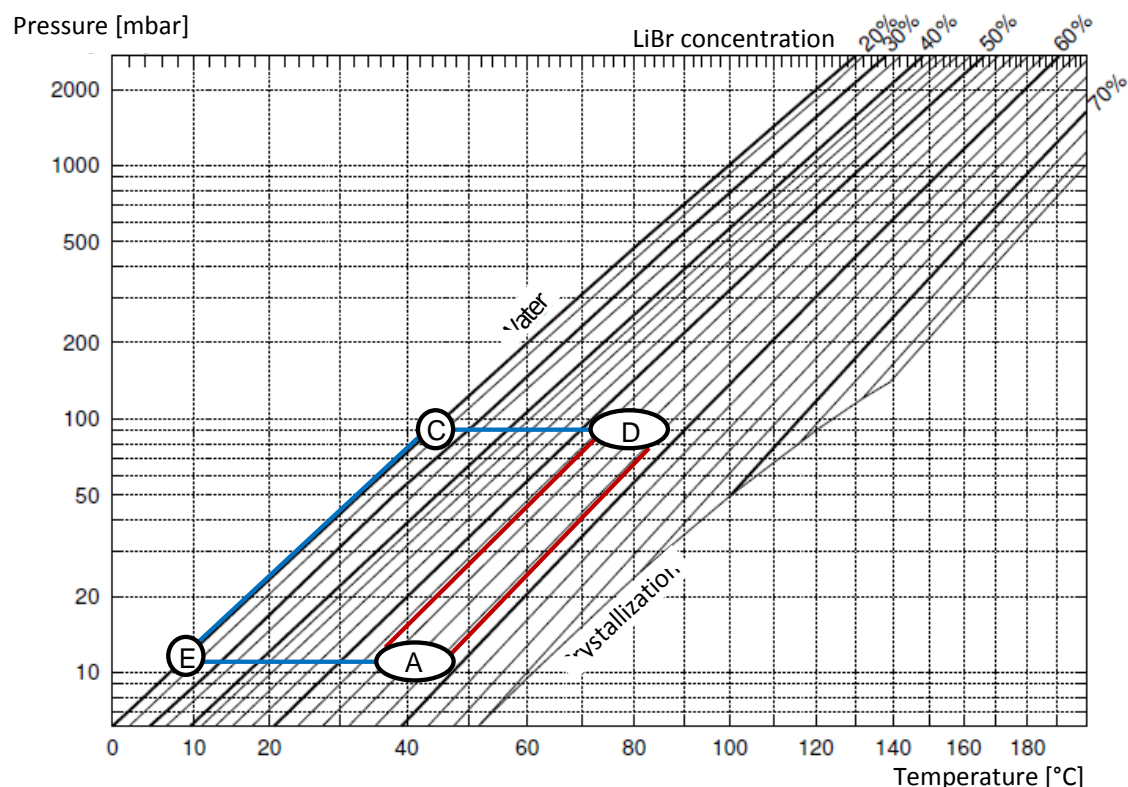

Fig. 1-16: Absorption heat pump cycle in the $\ln p$ - $1/T$ -diagram of water/LiBr (Feuerecker 1994)

Ammonia, in contrast, is toxic, flammable and explosive. Depending on the charge, special safety precautions are necessary. The vapour pressure is high (see Fig. 1-17). Therefore, pressure vessels are needed and the solution pump requires more energy.

Water has a significant vapour pressure as compared to ammonia and, consequently, a rectification unit is essential. A great advantage is that the ammonia/water solution does not crystallize. Ammonia/water permits the generation of very low refrigeration temperatures down to -40°C and the use of high heating supply or cooling water temperatures if the driving temperature is high enough. Ammonia/water systems are slightly more complex, larger, not as efficient as water/LiBr systems and need more auxiliary power.

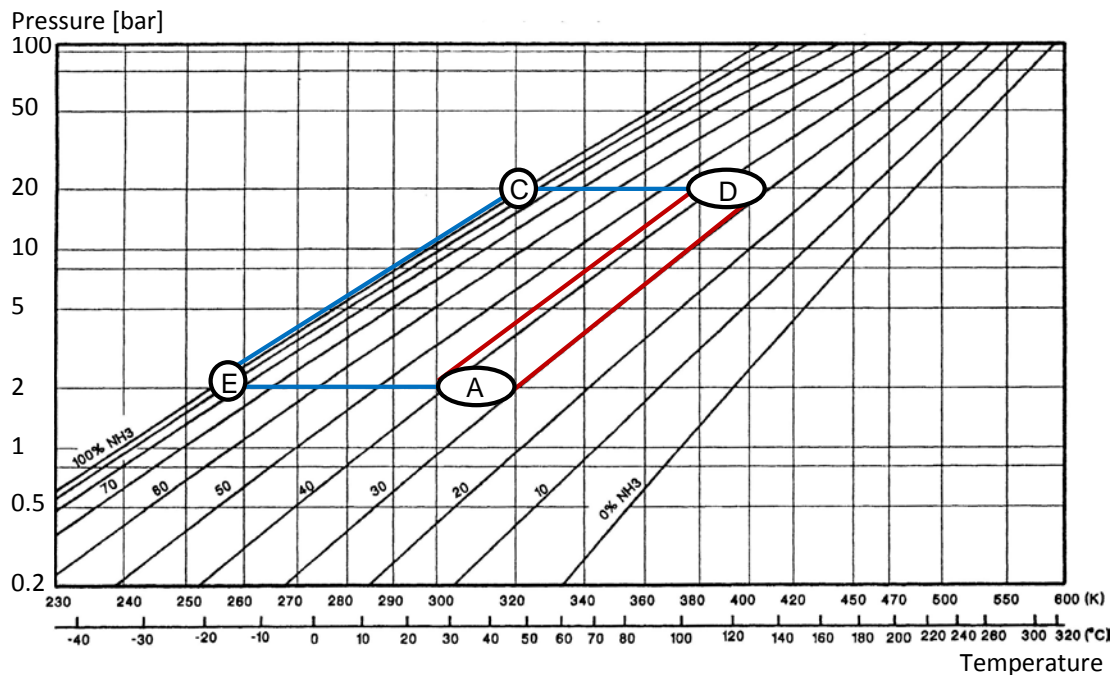

Fig. 1-17: Absorption heat pump cycle in the $\ln p-1/T$ -diagram of NH_3/water (Ziegler 1984)

One commercially available absorption chiller uses water/LiCl as working pair. In this case advantage is taken from the fact that the solution crystallizes at higher concentration for storage purposes.

In recent years, new working pairs basing on ionic liquids as absorbents have been investigated (Radspieler and Schweigler 2011), (Schneider, Schneider et al. 2011), (Seiler, Schneider et al. 2010). Ionic Liquids are considered to have a high potential to overcome the weaknesses of the currently prevalent pairs. Moreover, cycles or applications may become feasible whose development has failed up to now due to problems with the working pairs, such as highly efficient absorption chillers (triple-effect chillers) where sulphuric or phosphoric acid have been discussed as absorbents. The research performed on ionic liquids within Annex 34 is described in section 3.4.1

1.2.5 Adsorption cycle

In adsorption chillers the thermal compressor is the only component that operates according to a different working principle than in compression chillers and absorption chillers. Here the suction of the refrigerant vapour is executed by the adsorption bed. The adsorption bed consists of a heat exchanger and – attached to it – adsorbent. The adsorbent is a porous, solid material with a high internal surface area. The adsorbent

binds the refrigerant vapour on the surface in the pores and thereby causes the suction effect. Like absorption also during the adsorption process heat is released.

When the adsorbent is loaded up to a certain level it needs to be regenerated. This is achieved as in absorption machines by heating the adsorbent up to a minimum temperature and driving off the refrigerant vapour to the condenser. Heat is therefore required.

The process of adsorption and desorption works discontinuously. The adsorbent either adsorbs or desorbs refrigerant vapour. Therefore, usually at least two adsorption beds are installed operating in opposite phases (Aristov, Sapienza et al. 2012). However, one adsorption bed would be sufficient for this process.

During the adsorption phase the adsorption bed must be connected to the evaporator while during desorption phase the adsorption bed must be connected to the condenser. This could be controlled by actuated valves, but it is also possible and typical to install flaps (check-valves), which open and close automatically, depending on the pressure difference between adsorption bed, evaporator and condenser.

Not only the adsorbent but also the heat exchanger needs to be warmed up and cooled down when switching between adsorption and desorption. This is the weak point of an adsorption type TDHP. The cyclic process requires additional heat and leads to fluctuating outlet temperatures in all hydronic loops. Due to a lack of heat recovery basic adsorption type TDHPs are less efficient than absorption type TDHPs. However, there are several concepts to reuse the sensible heat of the adsorbent and the heat exchanger. An additional operation phase between adsorption and desorption, which is called heat recovery phase, is often introduced. In commercial applications two concepts are applied. Both require at least two adsorption beds:

1. A direct hydronic connection between the adsorption bed in desorption mode and the adsorption bed in adsorption mode is established. Both beds approach the approximate mid-temperature.
2. The inlets and the outlets between the adsorption beds are not switched simultaneously, but shortly after each other. Thus, the warmer hydronic outlet is connected to the hot water loop while the lower outlet is connected to the cooling water loop.

With these measures some heat recovery is achieved but only half of the heat can be used at most. Other measures taken involve reducing the amount of inert thermal heat capacity. Thus, the heat exchanger needs to be designed in a way the little heat capacity is added to the adsorption bed. This is a matter of the design as well as on the selected material of the heat exchanger. Moreover, adsorbent which has a high load lift in the required pressure and temperature range should be used. This is a matter of choice of the refrigerant-adsorbent combination.

In the beginning of a new adsorption phase (when the adsorbent is unloaded), the produced cooling in the evaporator or heating power in the adsorber is high, but it decreases during the process. However there is no natural point in time when the adsorption should stop. The duration of the adsorption and desorption phase is a trade

of between efficiency and power. While short cycles lead to higher power, long cycles lead to higher efficiency. The control strategy of the TDHP is therefore of interest. In principle three cycle duration mechanisms are known:

1. The operation phases are switched after a fixed period of time.
2. The operation phases are switched when the heating or cooling power surpasses a certain level.
3. The operation phases are switched when the bed is within a set temperature difference from the fluid heating or cooling it.
4. This requires measurement in the external circuits.

Many working pairs are possible for adsorption type TDHPs. However, the most common working pairs are water/silica gel, water/Zeolithe and ammonia/activated carbon. Fig. 1-18 shows the Dühring diagram of water/silica-gel 127B.

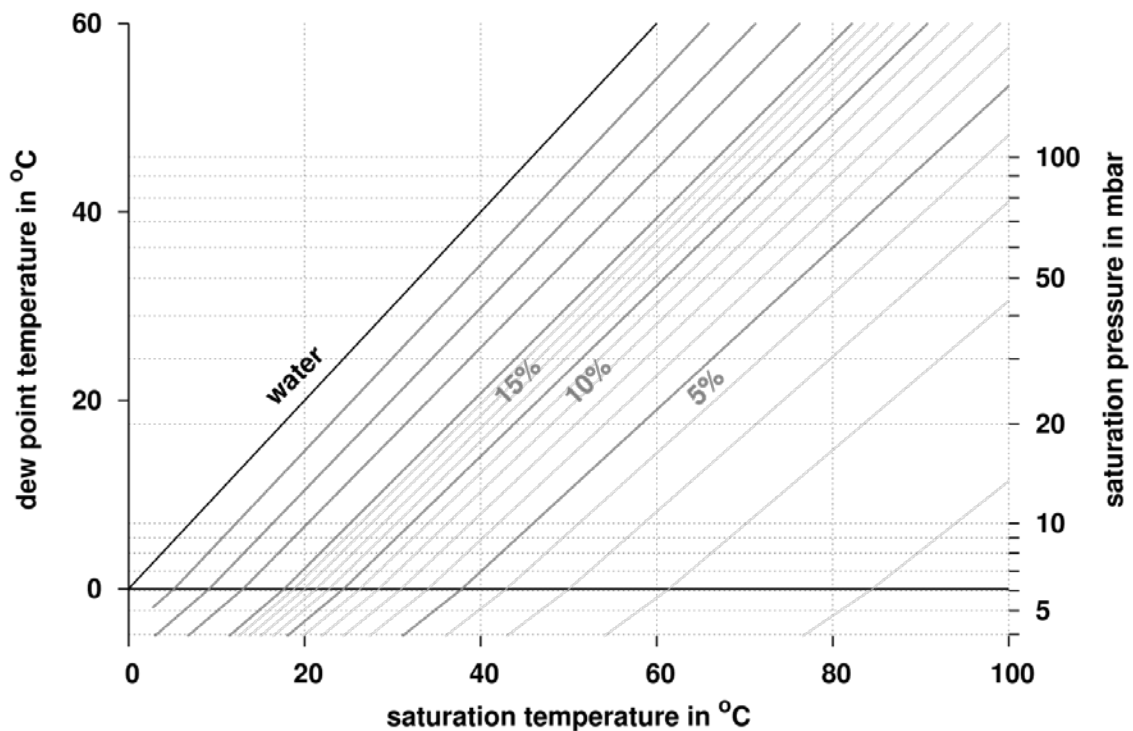

Fig. 1-18: Dühring-Diagram for Silica-Gel 127B. © Fraunhofer ISE

When comparing adsorption and absorption type TDHPs several advantages and disadvantages occur.

- There is no solution pump required within adsorption type TDHP, which may reduce investment cost. However flaps/check valves are needed to separate the main components.
- No solution heat exchanger is required, which reduces the investment costs.
- Due to the lack of an adequate heat recovery process the efficiency of adsorption type TDHPs is usually lower.
- The outlet temperatures of the adsorption type TDHP fluctuate.
- Mass flow variation may occur during the switching process.

- Compared to absorption crystallization is not an issue for adsorption

Both technologies could operate under vacuum conditions when using water as refrigerant or at high pressures when using ammonia as refrigerant.

1.2.6 Alternative TDHP Technologies

Alternative TDHP technologies to ab- and adsorption cycles are available and were partly discussed within the Annex 34 framework. Such cycles are:

- desiccant cooling systems for direct cooling and drying of air. Only the closed-cycle cases for heating and more specifically the sorption systems, are discussed in this report;
- hybrid absorption/compression systems (presented by the the Institute for Energy Technology);
- ejector cycles (presented by CanmetENERGY);
- TDHPs based on the double Rankine cycle (presented by École Polytechnique de Lausanne);

The basic principle of an ejector refrigerant cycle is that a fluid is accelerated to high speed (above the speed of sonic) by pressing it through an ejector. According to the ventury effect the pressure is reduced when the fluid is accelerated through the ejector. The ejector has a secondary opening were the reduced pressure than can be used to suck fluid from an evaporator. This device operates as an thermal compressor and can be used as a TDHP. More information about ejector cycles can be found in (Aidoun, Giguère et al. 2011; Dahmani, Aidoun et al. 2011; Scott, Aidoun et al. 2011; Scott and Aidoun 2011).

Another option of a TDHP is the ORC-ORC cycle. ORC stands for organic Rankine cycle. In power plants a clockwise operated ORC process can be used to convert heat to mechanical (and with the usage of a generator into electrical) energy. A counterclockwise ORC can be used as heat pump powered by mechanical energy. In an ORC-ORC process the mechanical energy of the clockwise ORC is used to power the compressor of the counterclockwise ORC. Therefore such a device is a thermally driven heat pump. More information about this technology and first results of a new prototype can be found in (Demierre and Favrat 2008; Demierre and Favrat 2011; Demierre, Henchoz et al. 2012)

1.3 Market overview

In the following the current situation on the overall heating and cooling market is shown. In that way, the focus is on heat pumps on one hand and on the solar cooling market on the other hand. Methodically, an overview about selected publications is given, which deal with future market situations. Within Annex 34 no own scenario was derived. The energy demand for heating and air conditioning of the world — especially in Europe — is presented with focus on future development trends as presented in climate change models.

In addition to the global situation, the market situation has been investigated within several country reports by the project participants. Thereby information on the climate, building stock, key market players, the Heating, Ventilation and Air Conditioning (HVAC) market and competing- as well as reference technologies are provided especially for the participating countries. These country reports are available in the internal section of the annex34 webpage.

1.3.1 Global demand for heating and cooling

The overall classification of the heating and cooling market is presented in Fig. 1-19 according to the presentation of (Dieryckx 2011).

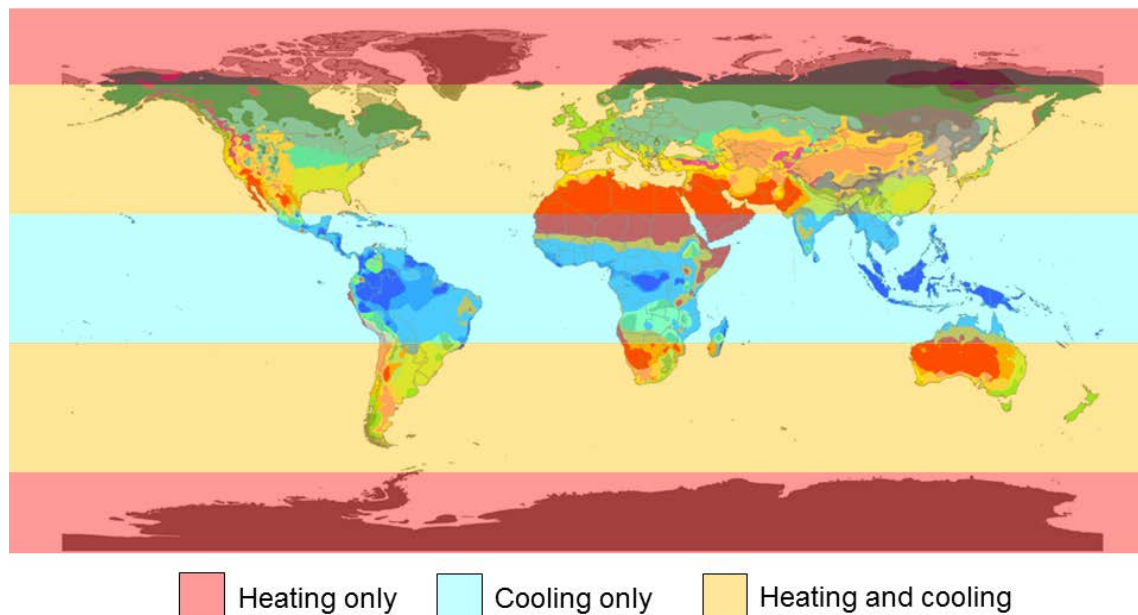

Fig. 1-19: Classification of the global heating and cooling market. World map of Köppen-Geiger climate classification (University of Melbourne, 2010) as basis and category groups according to (Dieryckx 2011).

This map is used in order to clarify how different the climates in each specific region are (cf. country specific labelling) and further to get an overall impression of the expected heating and cooling demand (cf. horizontal labelling stripes). Nevertheless, it is just a snap-shot and changes of both labels have to be taken into account due to the effect of climate change caused by mankind.

1.3.2 Global energy demand for heating and cooling – possible development trends

(Isaac and van Vuuren 2009) assessed the potential development of energy use for future residential heating and air conditioning in the context of climate change. According to a source from the International Energy Agency (IEA) in 2004 worldwide, households generally consume about a third of all end-use energy as well as more than half of this energy is typically used for heating in countries with a temperate climate. Concerning the energy demand they provided information of a median and a reference scenario. In case of the median scenario the energy demand for air conditioning increases rapidly in the 21st century, while the increase is from close to 300 TWh in 2000, to about 4000 TWh in 2050 and more than 10,000 TWh in 2100. The authors mention an increasing income in the developing countries as chief

cause. In contrast, the energy demand for heating increases too, but much less rapidly. Reasons are the increasing living standard as in most regions with the highest need for heating incomes are already high enough for people to heat their homes to the levels they wish to as well as a gradually rising per capita floor space is reported. For the reference scenario the global air-conditioning energy demand is expected to increase by 72% due to climate change and the global heating energy demand decreases by over 34% by 2100. However, the effect of climate change on regional scale is distributed unequally across the globe. The net effect of climate change on global energy use and emissions is stated to be relatively small as decreases in heating are compensated by the increases in cooling. Up to 2050, all of the investigated scenarios tend to a net decrease in energy demand, while in long term an increase is possible. Most of the forecast growth in air conditioning occurs in Asia, since Africa mostly remains too poor for large-scale use of air conditioning. India stands out as the country with the greatest potential demand for air conditioning according to the present climate. Here, an even further grow is expected if temperatures increase as a result of global climate change.

(Sivak 2009) especially investigated the energy demand for cooling in the 50 largest metropolitan areas of the world while he used local cooling and heating degree-day data neglecting the influence of climate change. Similar to the studies of (Isaac and van Vuuren 2009) Asia is identified as most growing market because the warmest 11 metropolitan areas are in this area (in India, Thailand, Vietnam, Philippines, Indonesia and Pakistan). According to his study Sivak turned out the following main results:

- Most of the largest metropolitan areas are in developing countries (38 out of 50), and most of them are in warm to hot climates.
- All but two of the top 30 metropolitan areas in terms of cooling degree days lay in developing countries.
- The potential cooling demand in most of the metropolitan areas in developing countries (24 out of 38) is greater than heating demand.

The main outcome is that increasing personal income probably leads to an unprecedented increase in energy demand in many developing countries. The potential cooling demand of Mumbai for example is about 24% of the demand for the entire United States. Even though air conditioning of dwellings in developing countries is currently on a rather rare level increasing personal income is expected to change that (Sivak 2009).

In Europe generally about 40% of the primary energy consumption is used for services in buildings (private and commercial) which coincidences quit well to the numbers previously mentioned about the world. This value is related for purposes as heating, hot water, air conditioning, lighting and other mainly electrical equipment.

(Aebischer, Jakob et al. 2007) investigated the impact of climate change on thermal comfort, heating and cooling energy demand in Europe. Thereby, they analysed possible changes in heating and cooling energy demand over the next 30 years for two climate variants: A first case for a mean annual temperatures remaining constant and a second case in which temperatures increase by +1°C in winter and +2°C in summer until 2035. According to the reference year of this study in 2007, the authors' state that the amount of energy required for heating is greater by far than the energy used

for space cooling on a national basis – even in the service sector. As previously mentioned they also report of a steady increase of cooled floor area while there is a decreasing trend for heating energy. Thus, “for much of Europe, increases in cooling energy demand due to global warming will be outweighed by reductions in the need for heating energy” as it is similar to the global findings (Isaac and van Vuuren 2009) (cf. global). To give an example and focusing just on the temperature increase while keeping the floor area according to data from 2005 constant, the calculated specific energy demand for heating (including preparation of sanitary warm water and process heat) and cooling of commercial buildings is reported for eight European cities, i.e. Athens, Murcia, Milan, London, Berlin Zurich, Copenhagen and Stockholm. Thus, the average specific energy demand for heating would decrease by approximately 11% while it would increase by approximately 38 % for cooling.

1.3.3 Germany – taking climate change into account

In the year 2008 Germany had a final energy consumption of 2500 TWh, according to (AGEB 2010). From this 29% was used for space heating (720 TWh) and 5% (125 TWh) for domestic hot water.

(Olonscheck, Holsten et al. 2011) investigated the heating and cooling energy demand and related emissions of the German residential building stock under climate change. According to the authors it is the first study that combines each of the relevant influencing factors, i.e. climate, demographic, economic and lifestyle factors, to forecast the energy consumption for room conditioning of residential buildings and resulting greenhouse gas (GHG) emissions in Germany until 2060. This study also takes into account the reduction of heating and cooling due to improvement of accommodations. For example, it is explicitly mentioned that this impact of improved building shells on reducing heating and cooling loads is excluded within the future scenario of the IEA technology roadmap (Taylor 2011) up to 2050 while (Fischedick 2011) reports of a great decreased heat demand for Germany in the future and therefore also a significantly reduction of the demand for gas (cf. slide 11) according to the “insulation trend” in the buildings.

Turning back to the study of (Olonscheck, Holsten et al. 2011) they calculated the future energy demand and resulting GHG emissions by means of different scenarios concerning warming, renovation, building activity, market penetration of room conditioning systems and energy sources used for heating. The results agree well to a number of international studies and to the global trend as previously mentioned. They found a reduction of the heating energy demand of 44–78% when comparing the years 1961–1990 with 2031–2060. They point out that of all considered factors renovation measures have the strongest influence on future heating energy demand of buildings. This underlines the role active policy making in this sector can play in regard to an ambitious climate protection policy. Independent of the climate change, an increase in the annual renovation rate from 1% to 3% could lead to a heating energy demand decline for German households of between 14% and 22%. Thereby, future trends in the efficiency rate of different heating systems have not been taken into account. Taking the changes in the number of air conditioners into account the authors conclude that future increases will have a strong impact on the actual cooling energy demand. Assuming an increase in the share of households with air conditioners from 1% to 13% they obtained a future increase of the actual cooling energy demand of more than 200%.

In summary a great cooling demand is to be expected even if global warming which has a great impact on this demand is neglected. Reasons are especially the increasing personal income within emerging developing countries but also the overall strive to comfortable living. Even for Germany, where much effort is carried out in order to insulate the building shell, and where in particular this positive conversion is already taken into account in the models of the authors, an increase of the cooling energy demand of up to 200% in the year 2060 is estimated. Globally, another source reports of an increase by 72% due to climate change. In contrast, the heating demand will decrease. Here, a decrease of 14 to 22% could have been found for Germany, 11% for Europe and 34% globally while the last two values do not take the insulation trend in buildings into account.

1.3.4 Heat pump market

1.3.4.1 Conventional heat pumps in Europe – current situation

Most recently, and in great detail, information on the heat pump market are presented within (Nowak 2011). In contrast to the previous editions of the outlook the level of detail increased. Thus, the category of thermally activated heat pumps was added to the questionnaire while this refers solely to the gas driven technology. However, only four installations (in Slovakia in 2010) are regarded in this outlook. Nevertheless, the market development of the conventional heat pumps is discussed briefly as the demand and the chances of the thermal technology will be visible. Thus, according to the European Heat Pump Statistics (Nowak 2011), more than 3.7 million electrical heat pumps have been sold since 2005 and could save 36.6 TWh of final energy and 15.5 TWh of primary energy compared to the use of conventional gas boilers. Moreover, they produce 29.1 TWh of renewable energy from air, water and ground and avoid 6.8 Mt of greenhouse gas emissions (Nowak 2011).

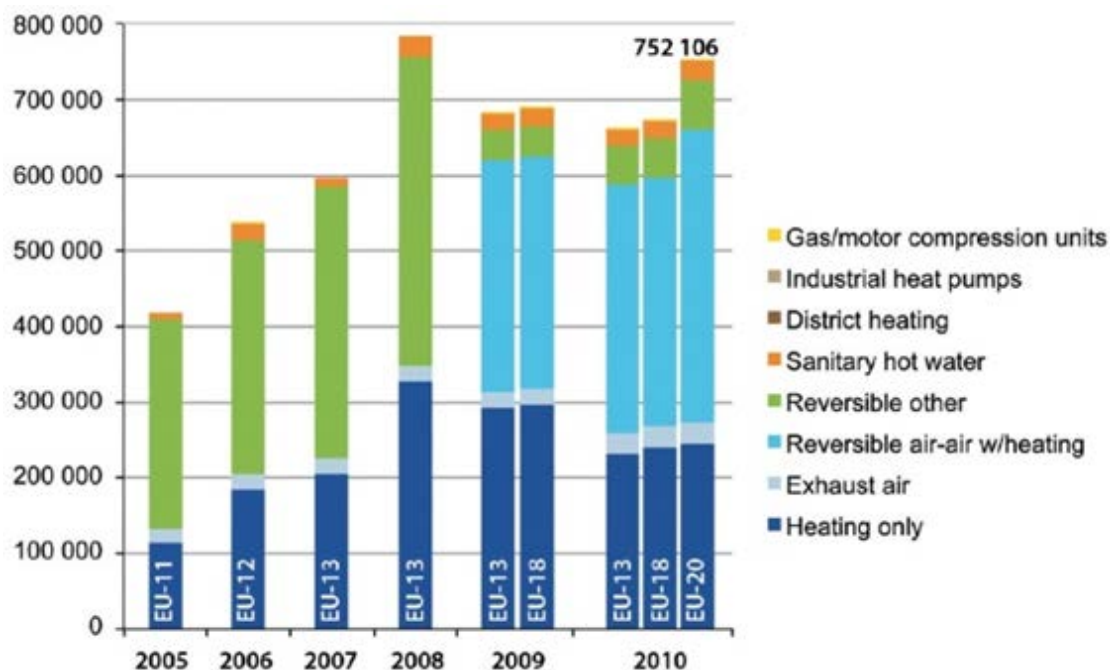

Fig. 1-20: Development of heat pump sales in Europe from 2005 to 2010. Source : EHPA.

Fig. 1-20 shows the development trend of heat pump sales for the last five years until 2010. Here, the break in sold numbers after the year 2008 has been addressed to the preliminary peak of financial crisis within this year and the economy stayed on a moderate track in 2010 according the journal *Japan Air Conditioning* (JARN) in 2011.

The market is growing. The technology is now being integrated into the mainstream European heating, ventilation and air-conditioning market. (Nowak 2011) reports of the emergence of a number of larger European “Heating and Cooling Groups”. In general high system performance is aspired to, and achieved through, optimized components and through combining heat pumps with other renewable energies like solar energy. Thus, (Sparber 2011) reports of 95 commercially presented systems combining solar thermal energy with heat pumps in different variations as one first outcomes of the IEA project Task 44 / Annex 38 Solar and Heat Pump Systems.

In Fig. 1-21 the sales are further separated into country and product category while the commercially systems in combination with solar energy as described by (Sparber 2011) have not been considered yet. With the exception of Scandinavia, we observe that in warm climates reversible air to air units are used while in colder climates a more stable source temperature is required — leading to a larger share of ground coupled units. In terms of categories covered, air as an energy carrier currently dominates the system choice in most countries and on the distribution side, hydronic systems (radiators, floor heating and wall heating) are often favoured for their comfort in central Europe (Nowak 2011).

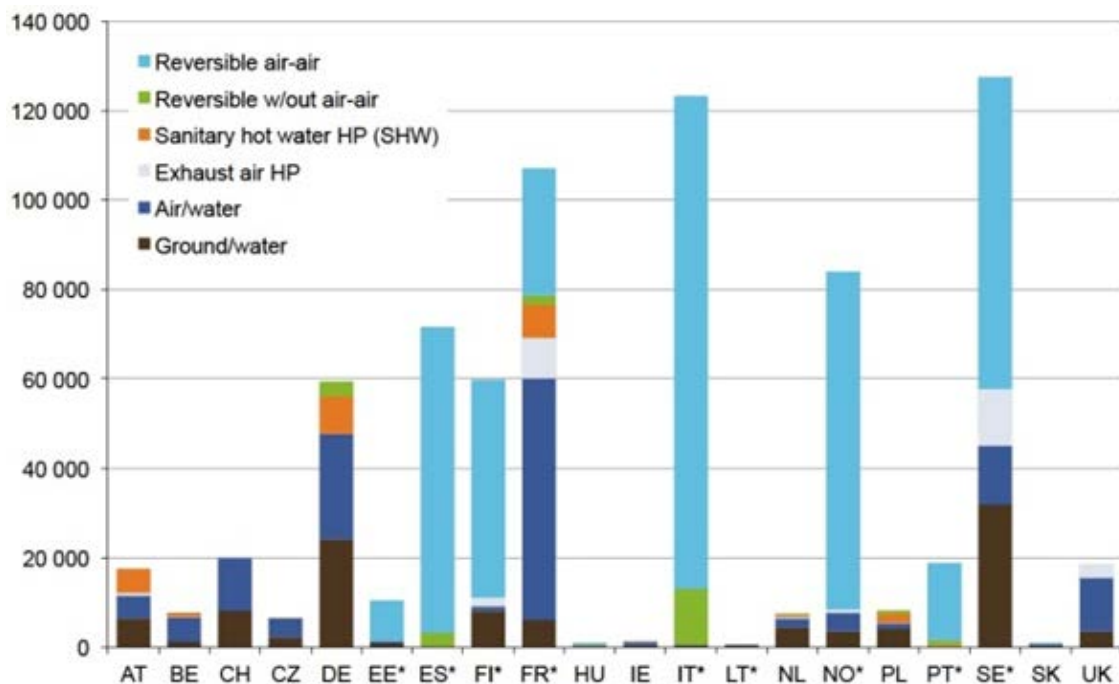

Fig. 1-21: Sales by category in 2010 (*includes sales of reversible air/air heat pumps). Source : EHPA.

1.3.4.2 Conventional heat pumps in other regions – current situation

According to (Groff 2011) the U.S. heating equipment market changes and the heat pump market share is growing. Different to other regions in the world, especially Europe and Asia, unitary air conditioners and furnaces are standard equipment for air conditioning and heating and natural gas is the most common source of energy for space and water heating (Dawoud 2011). (Groff 2011) estimated a growing sale of approx. factor 4 for heat pump water heaters from 2008 with approx. 15,000 in comparison to 2010. Furthermore, the numbers for ground source heat pump sales are at about 100,000 in the year 2011 and its growing sales were stimulated due to incentives and a greater awareness concerning global warming. In addition, the United States Department of Energy (DOE) published a new proposed ruling in June 2011, establishing three different regions with different minimum performance standards for residential gas furnaces and air conditioners – heat pumps and oil furnaces will have national minimum performance standards. In the south west split air conditioning systems will have minimum energy efficiency rates and seasonal energy efficiency standards. For the future (Groff 2011) mentions very bright prospects for heat pumps in North America.

1.3.4.3 Gas Heat Pump Market – current situation

A great progress could have been observed within the development of the gas heat pump market. This is the outcome of “Initiative Gas Heat Pump”, an outstanding European platform of German gas utilities and key European manufacturers of gas heating appliances that are supporting and stimulating the market introduction of this new heating technology (Dawoud 2011). (Tischer 2011) – who is also member of the “Initiative Gas Heat Pump”- reports of the successfully installation of more than 6,300 GAHPs across Europe (June 2011). According to (Bohenschäfer 2011) gas heat pumps are in an early market entry phase at European level but for the single and two-family houses still in testing phase. The technology is currently considered inadequate

for subsidy instruments and is therefore prevented from a successful market launch in contrast to the electro-heat pump.

1.3.4.4 Gas Heat Pump Market - perspectives

A great benefit of gas driven sorption heat pumps is their potential of primary energy savings in comparison to the conventional applied systems (cf. (Dawoud 2011)). Moreover, there is great sales potential due to the high availability of gas and a widespread gas network – as market basis - along Europe. Fig. 1-22 gives an overview of the amount of natural gas per final energy consumption of different households in 2008.

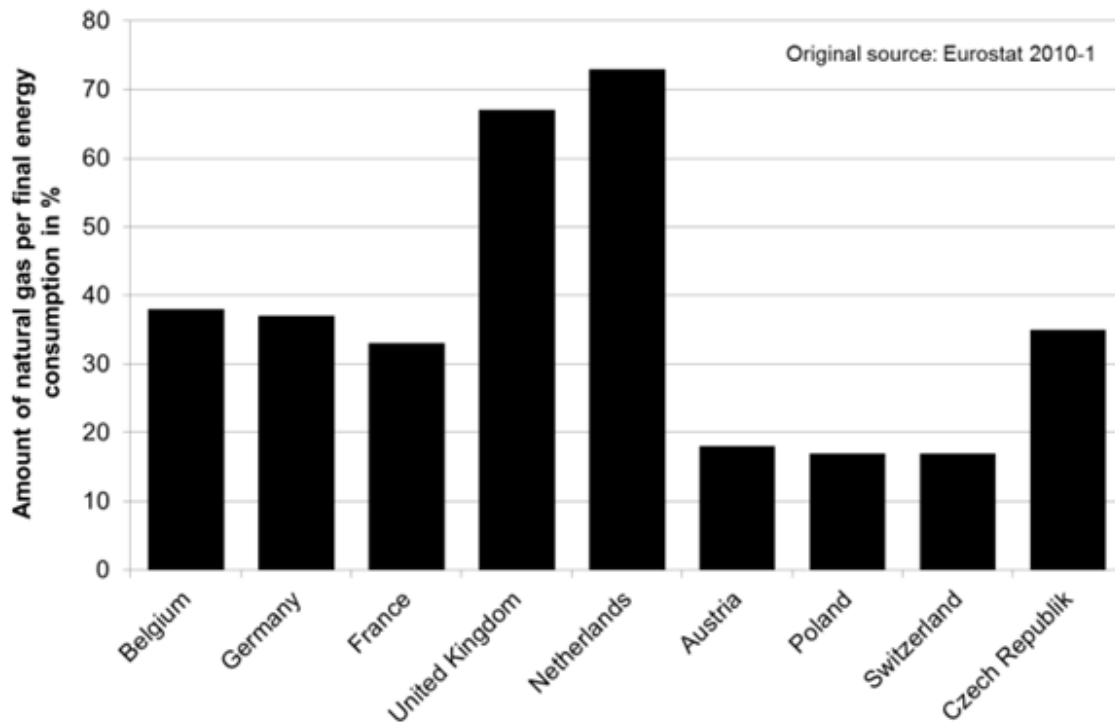

Fig. 1-22: Amount of natural gas per final energy consumption of private household in 2008 according to Bohnenschäfer.

The current situation and the goals to apply environmental heat as well as geothermal due to the use of heat pumps is presented Fig. 1-23. According to (Bohnenschäfer 2011) an overall great sales potential for heat pumps due to the national goals accompanied by systematic heat pump funding of the selected countries and a great export potential especially for Germany is expected. On a European level an especially great market potential is the United Kingdom which is expected due to the high availability of geothermal technology and their renewable energy goals (cf. Fig. 1-23). Primary energy and environmental advantages of gas heat pumps in comparison to electro heat pumps can be obtained particularly in countries with a less efficient- and ecological power generation. Additional advantages exist for a reuse of biogas or “wind-methane” as fuel (Bohnenschäfer 2011).

Nevertheless, funding for gas heat pumps in Europe is currently only supported by Germany, the Netherlands and Austria. To overcome the jump from the niche market into the heating market (Bohnenschäfer 2011) suggests temporarily tariffs for the market launch, and a more balanced design within the market incentive program

(MAP), to guarantee an equal treatment of both electro- and gas heat pumps that will finally to incorporate a distinction between the kind of drive and heat source of the promotion of gas heat pumps.

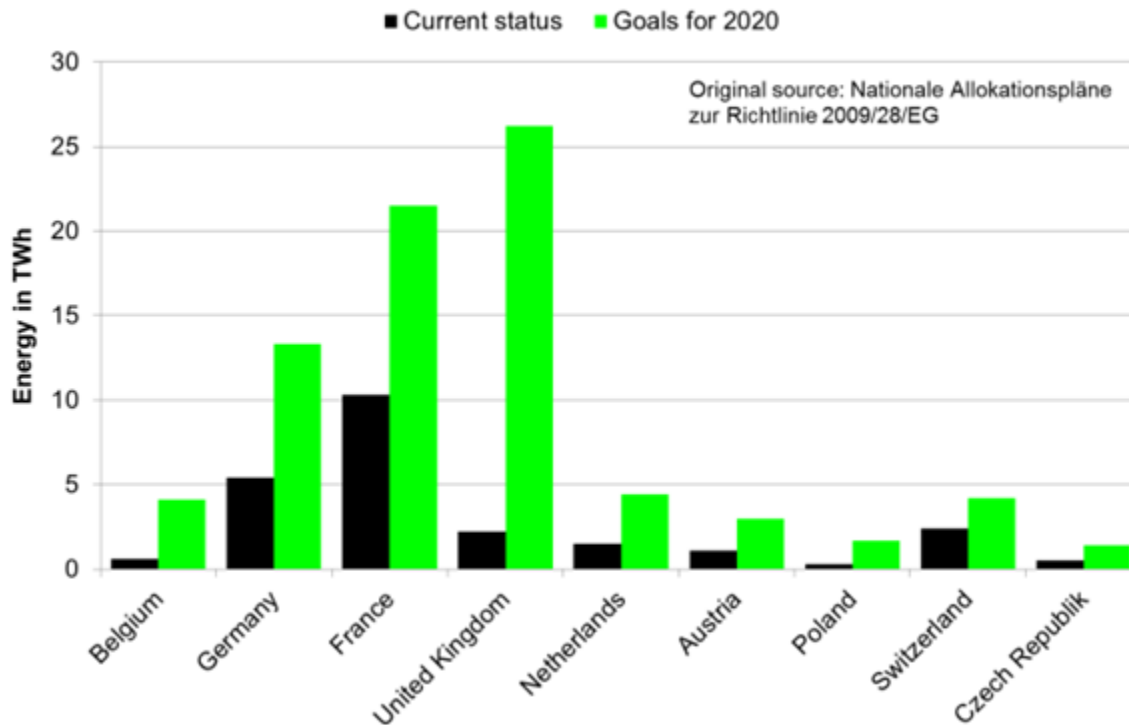

Fig. 1-23: Goals to apply environmental heat as well as geothermal due to the use of heat pumps according to Bohnenschäfer.

Observing the international level for countries with a favourable inclination to the natural gas infrastructure and -distributed application, the United States as well as the Russian Federation seem to be important future markets (cf. Fig. 1-24 and oppose to Fig. 1-19) (Portal 2009). Especially, a tend to energy efficient systems could have been observed within the United States as mentioned already.

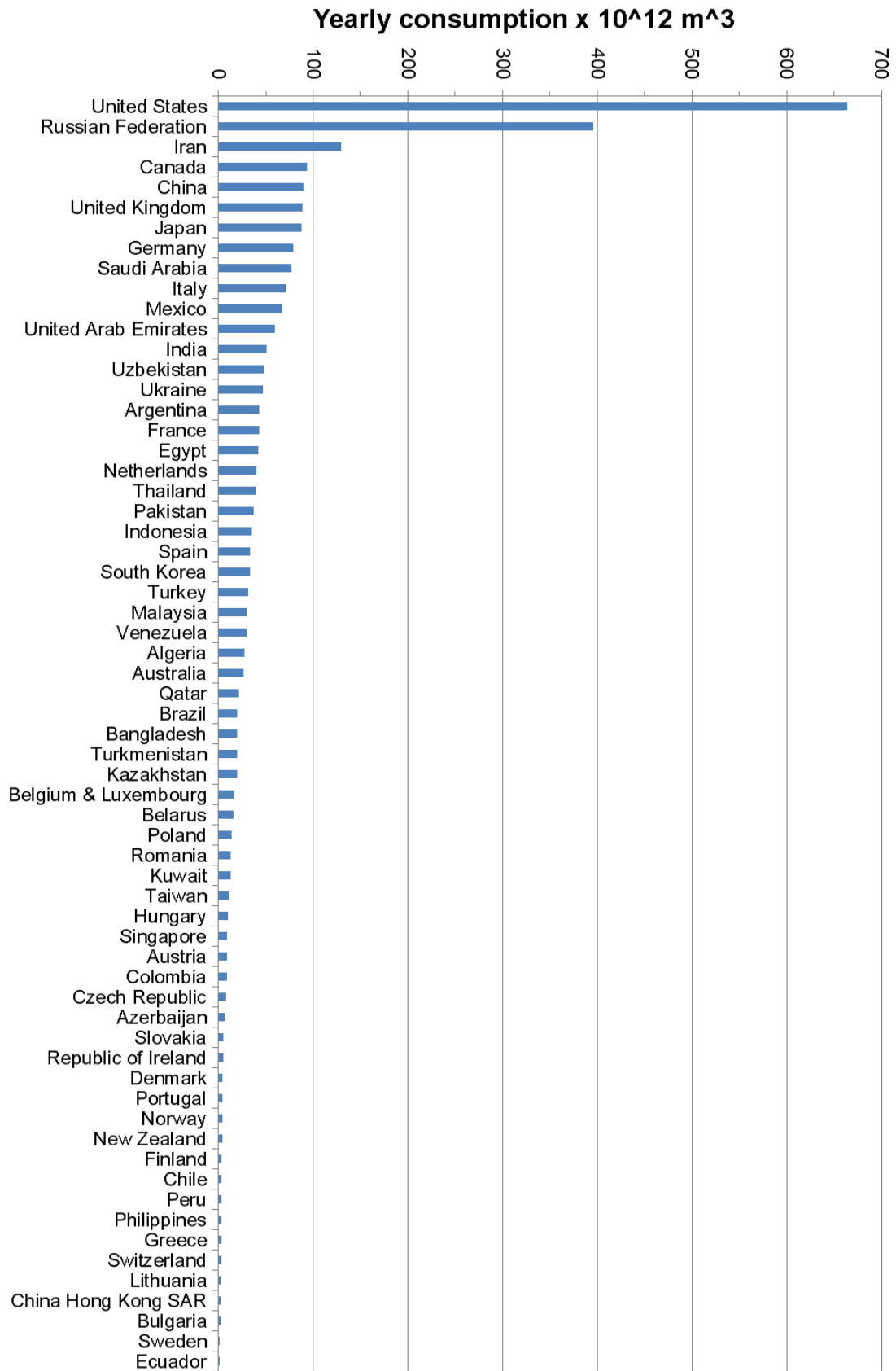

Fig. 1-24: Natural gas consumption by country in 2009. Source: FhG-ISE according to (Portal 2009).

The United States consume the most natural gas of which approx. 21% were consumed by residential applications and approx. 14% by the commercial sector (cf. data from the U.S. Department of Energy).

Turning back to Europe, the assessment of gas heat pumps in an integrated efficiency strategy for the heat market in Germany has been analysed in a study by the “Initiative Gas Heat Pump” (Fig. 1-25).

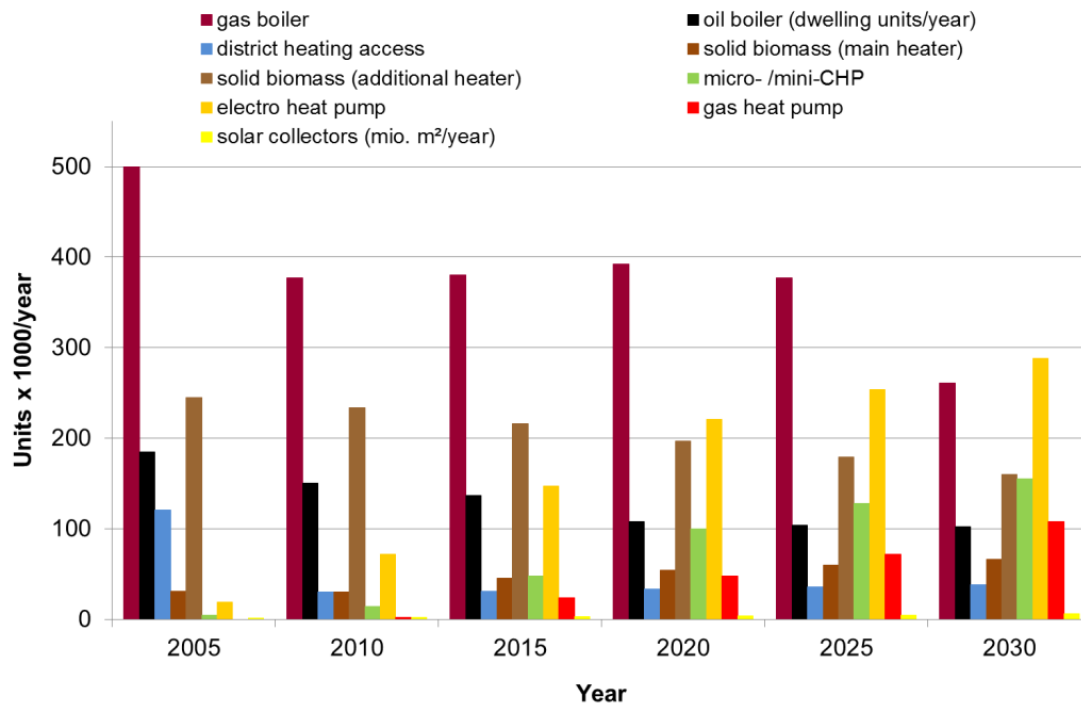

Fig. 1-25: Yearly installed facilities (Germany) in 1000 units per year and dwelling units per year for the oil boilers as well as million m²/year for solar collectors (Source: FhG-ISE with data according to table of (Kleemann 2010)).

According to this, the amount of the thermally driven technology might rise up to approx. one third of that of electrical heat pumps. As an overall result the final energy consumption could decrease from approx. 625 TWh in 2010 to approx. 510 TWh in 2030.

1.3.4.5 Other thermal Heat Pump Market – current situation

Even though theoretically more “non-gas” thermally driven machines could be used in a heat pump mode for heating purposes at low temperatures, currently not all manufacturers advertise their products for both purposes. It is expected that the combination with solar energy, (i.e., the use of low temperature of the collector field), leads to an increase of the overall system efficiency. Nevertheless, specific numbers of installations could not have been obtained as the actual operational purposes of the customer are not always known. For a wider use of this possibility still suitable “complete-systems” are required. So there is still need for the development of a marketable concept and pre-packaged solutions, including all required sub-components and the overall control of such systems.

SorTech also had the idea of applying its technology as heat pump from the beginning of the first prototypes. One of the first implementation of a SorTech machine in heat

pump mode was a prototype system at the Technische Werke Ludwigshafen AG which is still in operation. Sales development trends show a significant increase at the moment. Thus, sales increase of 16% could have been observed comparing the years 2008 to 2011 while solely systems are taken into account which are designed and put into operation by SorTech. Distribution and sales partners are not included. For the future of the heat pump application, SorTech expects a high potential as well as market in Germany, Austria, Switzerland and northern Europe, especially those regions where cooling plays a minor role. Nearly no limits exist in the application in combination with surface heating which are typically installed in new buildings. The required “low temperature need” are beneficial for the overall system performance.

In summary a positive trend for the application of conventional heat pumps as efficient technology which can make use of renewable energy is to observe (Henninger, Witte et al. 2011), (Jakob 2010). The importance of this technology is also due to the fact that it can consume electricity by wind energy (keyword: smart (electric) grids as treated in (Nowak 2011) for example). A very strong growth could have been observed for the gas heat pump market, showing next to the acceptance of efficient technologies in terms of environmental consciousness and the benefit of the already existing gas infrastructure which in long term can also be fed with bio gas, the potential and the influence of a willing union of German gas utilities and key European manufacturers “Initiative Gas Heat Pump”. The sorption technologies which can make use of waste heat or in combination with combustion engines (combined heat and power) at a low temperature level applying further ‘low temperature’ of a collector field for example also show a growing demand. The trend to surface heating which are typically installed in new buildings is very positive for the growth of this technology but still suitable “complete-systems” are required as well as governmental subsidies. However, the market suffers from the low recognition of this technology.

1.3.5 Air conditioning market

1.3.5.1 Conventional air conditioning market – current situation

Latest information (August 25, 2011) concerning the general trend in the global air conditioning market – according to a report: "Air Conditioning Systems: A Global Strategic Business Report" by Global Industry Analysts, Inc. – were presented at (PRWeb). Thus, 144.30 million units in volume sales are anticipated by 2017. Similar to the heat pump market the growth in the market for air conditioning systems within the next few years is expected to be led by energy efficient technologies like inverter-based air conditioning systems, i.e. an optimization of the electricity consumption of the mechanical compressor, and solar powered air conditioners in (Zachmeier, Schweigler et al. 2011). The authors point out that increasing effort on improving consumer awareness on energy conservation and environmental well-being will create considerable demand for these products over the next few years. Furthermore, the adaptation of inverter based air conditioning systems across the globe will be pushed through emerging standards. In addition, rapidly growing replacement needs will steer the market, especially in mature markets such as the United States and Europe. Here, replacement demand is also expected to be generated by the consumers’ need to replace their existing systems through quieter and more feature rich air conditioner models. Concerning the markets the Asian-Pacific continues to be the largest regional

market. Here, positive for the market development are the rise in urban population, a favourable job market in combination with resulting high income levels, increased household gains and rising per capita incomes, especially in countries such as China and India (PRWeb). Further information can be found in (Zachmeier, Schweigler et al. 2011).

1.3.5.2 Solar thermal cooling market – current situation

Looking back at the last five years, a remarkable progress has been made in the development of these technologies. New systems have been installed successfully and much data and experience has been collected by system monitoring – much of this as a result of the work of IEA-SHC Task 38. New manufacturers of solar thermally driven chillers have entered the market, as have companies offering complete systems for solar thermal cooling.

(Jakob 2011) reports of 225 produced and commissioned ab- and adsorption chillers from 2005 to 2009 with an accumulated cooling capacity of 5.8 MW. In September 2010 already nearly 280 documented installations in Europe were reported within a survey of worldwide installed solar cooling plants, carried out as part of the work of IEA-SHC Task 38 by (Sparber 2010) and Napolitano. A further 32 installations are documented on other but not specified continents. Worldwide, there are probably about 1000 systems installed. Among the documented systems, there are 168 pre-fabricated small-scale systems and 135 custom-made large scale installations. 23% of the small systems are installed in residential applications, while 38% are installed for air-conditioning in offices.

However, it must be realised that solar thermal cooling is still a niche technology. Despite the success and increasing reliability (of most) of the installed systems, and customer satisfaction, it is not yet possible to forecast a date for widespread application and use of the technology. One of the main obstacles for market penetration so far, especially concerning small and medium size systems, is the high initial cost of solar thermally driven cooling systems compared to conventional electrically driven cooling systems. Table 1-2 gives an overview solely on machines costs per technology for market available machines (Henninger, Witte et al. 2011).

Table 1-2 - Overview on machine costs (only) per technology (February 2011)

Operating conditions	Range of		
	machine costs in Euro	costs per kW-heat in Euro/kW	costs per kW-cold in Euro/kW
Absorption technology			
cold < 0°C, medium output 19,7 to 40°C and driving temperatures of 85 to 115°C. (valid for heating capacities of 45 to 145 kW)	21000 to 105000	476 to 868	1304 to 2625
cold < 0 °C, medium output 25 to 65°C (exceptions 70 to 80°C) and driving temperatures of approx. 200°C. (valid for heating capacities of 32 to 43 kW)	11030 to 22900	337 to 613	615 to 1355
cold > 0°C, medium output 27 to 45°C and driving temperatures of 70 to 110°C. (valid for heating capacities of 20 to 85,4 kW)	12500 to 30600	254 to 730	616 to 1703
Adsorption technology			
cold > 0°C , medium output 22 to 45°C and driving temperatures of 45 to 95°C. (valid for heating capacities of 22 to 40 kW)	10000 to 18000	446 to 542	1199 to 1446

(Jakob 2011) names the cost for complete cooling kits (sorption chiller, heat rejection, etc.). Thus, specific net costs are between 1,000 and 3,000 Euro/kW cooling capacity while installation costs are neglected.

Opposing these numbers to the conventional technology – applying a change course of 1 Dollar → 0.76 Euro - (cf. Table 1-3) the need for subsidies gets visible.

Table 1-3 –Technology and cost characteristic of heat pumps for heating and cooling in single-family dwellings, 2007 [20].

	North America		China and India		OECD Pacific		OECD Europe	
	from	to	from	to	from	to	from	to
Typical size (kW _{th})	2	19	2	4	2	10	2	15
Installed cost: air-to-air (Euro/kW _{th})	274	475	137	171	304	407	424	1087
Installed cost: ASHP (Euro/kW _{th})	361	494	228	304	426	1013	461	2422
Installed cost: GSHP (Euro/kW _{th})	380	646	334	456	760	3040	889	1723

In Germany for example additional funding for a gas driven heat pump systems in the range of 3000 to 4000 € is available due to the market incentive program (MAP). This can be combined with additional funds for a solar thermal installation which can sum up to one-fourth of the overall investment costs.

Anyhow, as far as technical aspects are concerned, the main components of solar thermal cooling systems are already well engineered, both for solar heating and for cooling and air conditioning. The main technical weaknesses are still at the system level, particularly in connection with energy management of systems as a whole, and including the efficiency of the heat rejection unit. In addition, installation, commissioning and operation require well trained technical competence and understanding of the technology.

To summarize, the technology has reached the stage of early market deployment, and can be an economically feasible solution under particular boundary conditions. It even has found its place within the Technology Roadmap of the IEA (Taylor 2011) as supporting technology. What is now required are appropriate incentives as previously mentioned and/or support schemes, training and education programs for installers, companies and planners as well as demonstration programs with accompanying monitoring activities.

2 PERFORMANCE EVALUATION

2.1 Standards and Definitions

Within Annex 34, a survey on existing standards, guidelines and definitions of performance figures was performed to get an overview about all relevant national and international standards and other normative documents. This survey is the fundament for further work in developing later standards in order to:

- Setting the basis for international standards which can be accepted by countries without national standards;

- Extend specific standards to a broader applicability, e.g. not only focusing on absorption chillers but also adsorption chillers or heat pumps;
- Interconnect standards to a consistent part. E.g. standards about solar driven heat pumps should be compatible with standards applicable to solar collectors and electrical heat pumps;
- Find broadly accepted definitions of performance figures for later development of quality assurance tools, e.g. quality labels and certifications.

The survey included documents published by the following institutions:

- International Organization for Standardization (ISO)
- European Committee for Standardization (CEN)
- American National Standards Institute (ANSI)
- American Society of Heating, Refrigerating and Air-Conditioning Engineers (ASHRAE)
- Air-Conditioning, Heating and Refrigeration Institute (AHRI)
- The Japan Refrigeration and Air Conditioning Industry Association (JRAIA)
- Japanese Standards Association (JSA)
- The Association of German Engineers (Verein Deutscher Ingenieure VDI),
- The German Institute for Standardization (Deutsches Institut für Normung DIN),

The standards are subject to continuous improvements. The given description took into consideration mainly documents (both final and preparatory) published until December 2011. Full results of this survey can be found in the technical report (Malenković, Schicktanz et al. 2012) on the internal part of the Annex34 webpage. The following chapters provide a short summary.

2.1.1 Definition of the analysis criteria

For the analysis of the current standards and guidelines, the following aspects of the collected documents were accounted for:

- General information – current version, on-going revisions, etc.;
- Scope of the document - purpose, area of application, etc.;
- Boundary conditions – operating conditions for testing, climate conditions and demand profiles for performance calculations;
- System boundaries and definition of performance figures;
- Brief description of the calculation and/or test method (type of tests, ambient conditions, performing tests etc.);
- Part load definition and calculation methods (e.g. efficiency diminishing factors for cyclic operation);
- Additional information of interest (e.g. rating, reports etc.).

The documents have been further analysed in regard to their applicability for different TDHP-technologies and applications.

In Annex 34, three levels of performance figures have been defined:

1. COP and EER as the unit efficiencies at nominal rating conditions under steady-state operation;
2. SCOP and SEER for the assessment of the unit performance under defined, time dependent rating conditions over a certain period of time, usually a year;
3. SPF for the assessment of the system performance under defined, time dependent rating conditions over a certain period of time, usually a year.

Additionally, primary energy factor (PER) has been defined in order to be able to compare different systems and different technologies by the usage of primary energy sources (primarily fossil fuels such as oil or gas) for different applications, as well as systems based on more than one final energy source (e.g. electricity and gas).

Accordingly, the standards and guidelines were grouped into these categories:

- Power related efficiency on apparatus level - definition of nominal performance figures COP, EER;
- Energy related efficiency on apparatus level - standards for the assessment of seasonal performance figures SCOP/SEER
- Energy related efficiency on system level – standards for the assessment of the seasonal performance factor (SPF)
- Quality labelling schemes for TDHP
- Further relevant standards and methods, related to TDHPs and/or systems

Table 2-1 gives an overview of the assessed documents.

Table 2-1: Overview of analysed standards and guidelines

Standard	Title	Status
Standards and guidelines for the assessment of the COP/EER		
AHRI 320	Water-Source Heat Pumps	1998-01-01
AHRI 325	Ground Water-Source Heat Pumps	1998-01-01
AHRI 330	Ground Source Closed-Loop Heat Pumps	1998-01-01
ANSI/ASHRAE 37	Methods of Testing for Rating Electrically Driven Unitary Air-Conditioning and Heat Pump Equipment	2009-06-24
DIN 33830-4	Anschlußfertige Heiz-Absorptionswärmepumpen. Leistungs- und Funktionsprüfung	1988-06
EN 12309-2	Gas-fired absorption and adsorption air-conditioning and/or heat pump appliances with a net heat input not exceeding 70 kW – Part2: Rational use of energy	2000-04-01 under revision
EN 14511	Air conditioners, liquid chilling packages and heat pumps with electrically driven compressors for space heating and cooling	2011-11-30
JIS B 8622	Absorption refrigerating machines	2009-12-21
Standards and guidelines for the assessment of the SCOP/SEER		
AHRI 560	Absorption Water Chilling And Water Heating Packages	2000-01-01
ANSI/ASHRAE 182	Method of Testing Absorption Water-Chilling and Water-Heating Packages	2008-06-25
EN16147	Heat pumps with electrically driven compressors - Testing and requirements for marking for domestic hot water units	2011-04
EN 14825	Air conditioners, liquid chilling packages and heat pumps with electrically driven compressors for space heating and cooling - Testing and rating at part load conditions and calculation of seasonal performance	2012-04 under revision
Standards and guidelines for the assessment of the SPF		
VDI 4650-1	Calculation of heat pumps - Simplified method for the calculation of the seasonal performance factor of heat pumps - Electric heat pumps for space heating and domestic hot water	2009-03
VDI 4650-2	Simplified method for the calculation of the annual coefficient of performance and the annual utilisation ratio of sorption heat pumps - Gas heat pumps for space heating and domestic hot water	under development
EN 15316-4-2	Heating systems in buildings - Method for calculation of system energy requirements and system efficiencies - Part 4-2: Space heating generation systems, heat pump systems	2008-09 under revision

Note: The reviewed documents can be found in the reference section of this report with the following entries:

- (CEN 2000)
- (DIN 1988)
- (JSA 2011)
- (CEN 2011)
- (ANSI 2009)
- (AHRI 1998)
- (AHRI 1998)
- (AHRI 1998)
- (CEN 2011)
- (CEN 2011)
- (AHRI 2000)
- (ANSI 2008)
- (VDI 2003; VDI 2003)
- (CEN 2007; CEN 2007; CEN 2008)

2.1.2 Assessment of the documents

As the market for both electrically and thermally driven heat pumps is rising and the necessity to reduce primary energy consumption and increase the efficiency of energy systems is driving the market stakeholders to promote quality and performance assurance methods (e.g. EU Energy Labelling Directive), quite a lot of activity could be observed regarding the development and revision of related standards and guidelines recently. Additionally, a number of relevant publications and on-going projects are aimed at development and assessment of new testing or performance evaluation methods for heat pumps and their systems (e.g. HPP Annex 34, SHC Task 38, SHC Task 48, SHC Task 44 / HPP Annex 38, IEE SEPAMO). Moreover, a number of documents have been revised or developed during the course of the Annex. The reviewed standards and guidelines can be divided into three main groups with respect to the purpose of the described method:

- Methods for the assessment of the chiller/heat pump performance under steady-state rating conditions, for a single mode of operation (e.g. heating, cooling, DHW);
- Methods for the assessment of the chiller/heat pump performance for a certain period of time (e.g. year/season) under assumed boundary conditions (e.g. demand profile, climate), for a single mode of operation;
- Methods for the assessment of the chiller/heat pump performance including back-up system energy consumption under assumed boundary conditions, for a single mode of operation or combined operation (e.g. heating and DHW).

A comparison of the analysed documents is shown in (Table in Annex). From the comparison, the main conclusions are:

Testing, rating and performance calculation

- The definition of the performance figures is not consistent throughout the reviewed documents. For example, in some cases the electricity consumption includes the proportional consumption of peripheral devices (pumps, ventilators), in some it doesn't;
- The nomenclature regarding different performance figures is not consistent;
- Especially in the case of thermally driven heat pumps, not all technologies (absorption, adsorption, driving energy, different working pairs etc.) and/or applications (e.g. heating, cooling, DHW) are covered in the scope of the standards. In some documents, the testing methods apply only nominally to both absorption and adsorption machines, e.g. EN 12309-2. However, as pointed out in (Melograno, Fedrizzi et al. 2010), a clear definition of test conditions and procedures for discontinuous processes is not available;
- The European documents are related only to direct fired machines; only EN 12309-2 covers cooling applications;
- A number of standards apply only to a certain capacity range of the heat pumps;

- European standards are mostly consistent regarding the testing conditions, in particular the liquid and air temperatures and flow rates on the condenser and the evaporator of the heat pump;
- Standards for thermally driven heat pumps do not have separate figures for thermal and electrical efficiencies. In some cases, the electricity consumption is not considered, in some cases it is added to the thermal energy consumption;
- No consistent methods for full transient testing of heat pumps (both electrically and thermally driven) are currently available in reviewed documents;
- European testing procedures do not provide any accurate information on testing under part load conditions;
- Standard operating conditions provided within the documents do not fully cover the solar cooling applications. The chilled water temperatures are quite low and correspond to distribution systems with e.g. fan-coil; cooled ceilings are not considered. Generally, there is only one defined temperature level for the condenser/absorber circuit (except in EN 12306-2);
- There are no methods available for the calculation (estimation) of the SPF for entire systems (e.g. solar cooling systems including all components);
- In none of the documents a clear distinction between the thermal and the electrical performance of the heat pumps or systems is made;

Quality labels

- Only one quality assurance certification scheme for TDHPs was found in Europe, the German “Der Blaue Engel” for gas driven heat pumps in heating mode. No other technologies or applications are covered;
- Both minimum thermal efficiency and maximum electricity consumption per kW capacity are required, but only for steady state operation;
- The rating of the heat pump should be carried out according to a gas boiler testing procedure which is often not suitable for the implemented technology.

2.1.3 Dissemination within Annex 34

The results of this survey were widely spread. Many committees and conferences were visited by partners within Annex 34 to use the gained information for the development of further standards. The results were used at the following events and/or published in the following publications:

Conference Papers with oral presentations

- (Malenković and Schossig 2012)
- (Núñez, Malenković et al. 2011)
- (Malenković, Melograno et al. 2011)

Conference paper with poster

- (Fedrizzi, Malenković et al. 2012)

Articles

- (Malenkovic 2011)

Presentations (without publications)

- (Malenković 2012)

Input to standardisation bodies

- Participants of Annex 34 took an active role in CEN TC 299 “Gas-fired sorption appliances and domestic gas-fired washing and drying appliances” WG2 “Gas-fired sorption appliances” regarding the revision of EN 12309 “Gas-fired absorption and adsorption air-conditioning and/or heat pump appliances with a net heat input not exceeding 70 kW”
- Participants of Annex 34 took an active role in the development of VDI-guideline VDI 4650-2 “Simplified Method for the calculation of the annual coefficient of performance and the annual utilisation ratio of sorption heat pumps – gas heat pumps for space heating and domestic hot water.
- Inputs for the DIN workshop on the needs for standardisation regarding solar cooling technology.

Further utilisation of the results

Parts of the output of IEA HPP Annex 34 were / will be used in the following projects:

- IEA SHC Task 48 “Quality Assurance and Support Measures for Solar Cooling” – further development of the temperature bin method for the estimation of annual system performance
- IEA HPP Annex on fuel driven heat pumps – usage of performance figures and corresponding system boundaries
- IEA HPP Annex 38 / SHC Task 44 “Solar and Heat Pumps” - further development of the temperature bin method for the estimation of annual system performance
- IEE-Projet QAiST “Quality Assurance in Solar Heating and Cooling Technology” – Review of the relevant normative documents for solar cooling

2.1.4 Recommendations for future work

The assessment of the normative documents showed a general lack of harmonised and transparent testing, rating and performance evaluation methods for almost all TDHP technologies and applications. On the other side, standards, guidelines and quality assurance schemes for electrically driven heat pumps, in spite of some inconsistencies and obvious room for improvements, are well developed in all countries and regions covered by the survey. This may have a negative impact on the future market development of thermally driven technologies. In order to avoid that, the following normative actions are recommended:

- Unambiguous and consistent definition of performance figures for TDHP; harmonisation with other technologies;
- Harmonisation of standard testing conditions for existing applications;
- Development of standard testing conditions for applications not covered by current standards (e.g. solar cooling, solar panels as heat sources etc.);
- Extension of the scope of existing documents to all thermally driven technologies and their applications;

- Development of test procedures suitable for all thermally driven technologies, in particular for units with non-stationary (cycling) operation;
- Development of an easy-to-use, transparent and reliable method for accurate estimation of the TDHP and system performance for all applications. For comparability with electrically driven heat pumps, a temperature bin method (as in EN 14825 or EN 15316-4-2) would be favourable.

Finally, one or more quality assurance schemes for different TDHP applications based on the normative documents and comparable to existing procedures for similar systems (electrically driven heat pumps, solar thermal combi-systems etc.) should be developed.

2.2 Definition of Performance Figures for TDHP and Systems Including TDHP

2.2.1 Introduction

Within Annex 34, a common framework for the evaluation of TDHP systems was developed. The methodology aims to be applicable for all different kinds of TDHP system configurations with different embedded components and hydronic configurations. The main idea is to have several boundary conditions on component and system level in which precise calculation procedures are defined independently from the specific system design.

This section covers a rough explanation about the general procedure and the different methods used. For a more detailed explanation and a complete list of performance figures see the technical report (Malenković 2012) in the internal section of the Annex 34 webpage.

2.2.2 Definition of Applications

2.2.2.1 Framework conditions

In Annex 34, thermally driven heat pumps (TDHP) and systems including thermally driven heat pumps designed for domestic and light commercial applications were considered. This corresponds to installations with a net heat output of up to about 70 kW, although no strict limitations have been made. However, as a substantial portion of R&D activities related to TDHPs in the recent years have envisaged applications in small to medium capacity range, Annex 34 focused on that potential market.

Only closed cycles, both absorption and adsorption heat pumps are covered in Annex 34. Open cycles, such as desiccant evaporative cooling (DEC), as well as gas driven, mechanical compression systems were not discussed. Both direct and indirect fired TDHPs were considered.

Regarding the energy source at the evaporator and the heat rejection system, no explicit exclusions were made. The driving energy for the TDHP and other system components was considered in total or partly, depending on the system boundary, as described in the subsequent chapters.

Although the main focus of the applications was on the domestic usage, most of the described cases would be applicable to a variety of commercial applications as well, such as hotels, offices, restaurants etc....

For an application of the procedure described below see the demonstration plant in the appendix of this report. For further applicability see the market reports in the internal section of the Annex 34 webpage.

2.2.2.2 System classification

A widespread definition of efficiency η for an energy system is the ratio between the sum of the total useful energy outputs from the system and the total energy inputs to the system, basically used for the system operation:

$$\eta = \frac{\sum_{i=1}^n Q_{out,i}}{\sum_{j=1}^m Q_{in,j}} \quad (1)$$

Depending on the system boundary used, these two energies may be defined differently – as described in the following chapters. However, a general classification can be made by the purpose of the TDHP system and the type of the driving thermal energy supplied to the TDHP unit. First classification can be made according to the driving energy:

- Direct fired TDHP – driving thermal energy input is the fuel supplied to the unit. For the calculation of the efficiency, it can be expressed as the gross heating content of the fuel based on the higher or the lower heating value.
- Indirect fired TDHP – driving thermal energy input is the heat supplied to the TDHP unit from the heat source over a heat exchanger. The most common energy carriers are hot water or steam.

TDHP system can be designed to cover only the heating or only the cooling load, or both simultaneously.

Taking this into consideration, TDHP systems can be classified according to Fig.

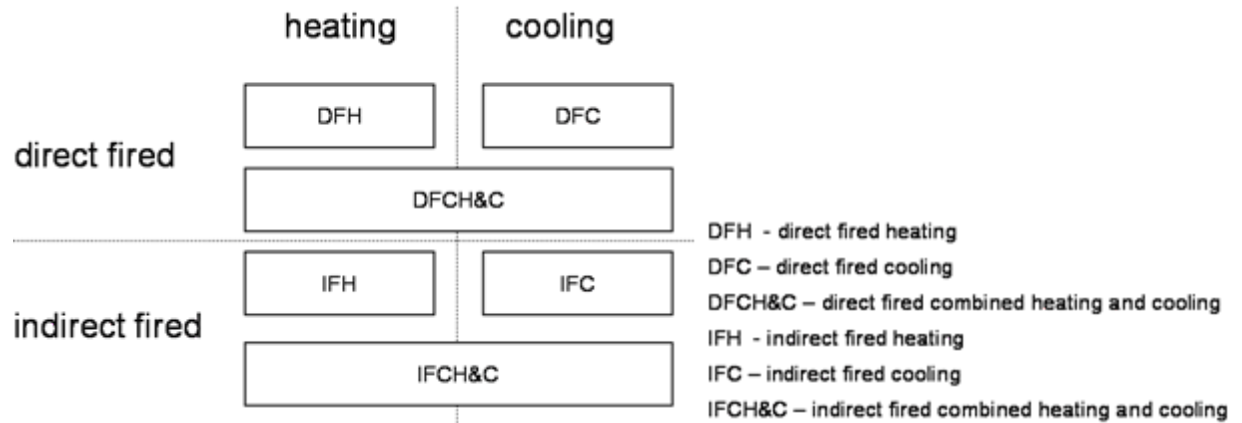

Fig. 2-1: Classification of TDHP systems.

2.2.2.3 Flow charts

For the representation of TDHP systems and system boundaries, Annex 34 adopted two different energy flow charts:

- A modified flow chart from IEA SHC Task 38 (Sparber 2008) partly considers the hydronics of the system and gives a detailed information on energy consumption of every component, as well as energy consumption to facilitate for energy flows between the components. The nomenclature used is as follows:
 - Q heat
 - E electric energy
 - Q_p primary energy
 - W water consumption
- A structured flow chart (“Square View”) developed in IEA SHC Task 44 / HPP Annex 38 (Frank, Haller et al. 2010) represents only energy flows and does not give particular information on the hydronic connections between the components. It also does not provide full information on the auxiliary energy consumption, especially regarding pumps, etc.

In the modified Task 38 representation, the energy flows delivering cold are shown in the engineering sense – the arrows are pointing towards the component (or user), where the energy is being used, delivered as useful energy or used for an energy conversion process.

In the Square View representation, the energy flows are represented in the physically correct way, energy flows from the component with higher temperature (or pressure for primary energy flows, e.g. gas) to the component (or end user) with a lower temperature.

Both charts are described in detail in Chapter 4 System Technology.

2.2.2.3.1 Reference TDHP system

From an analysis of configurations and operation modes of TDHP systems section 1.2, a reference system was developed, Fig. 2-2.

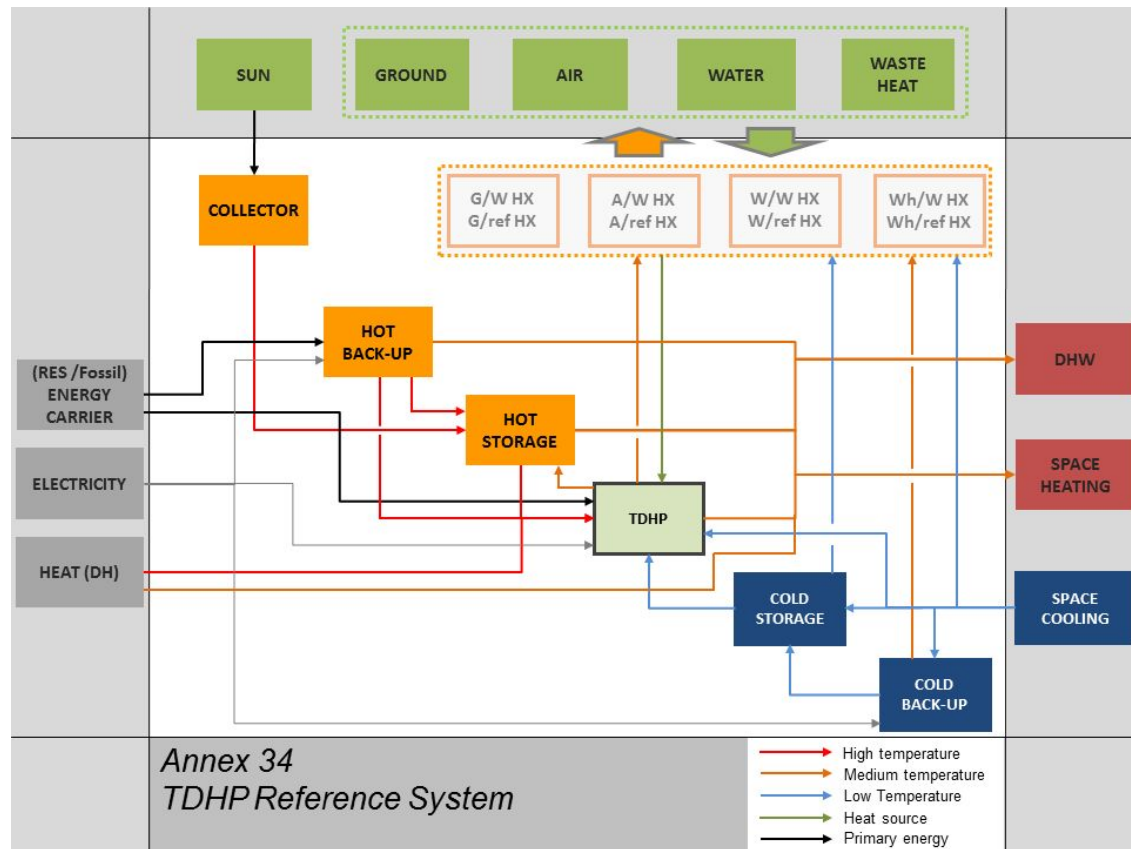
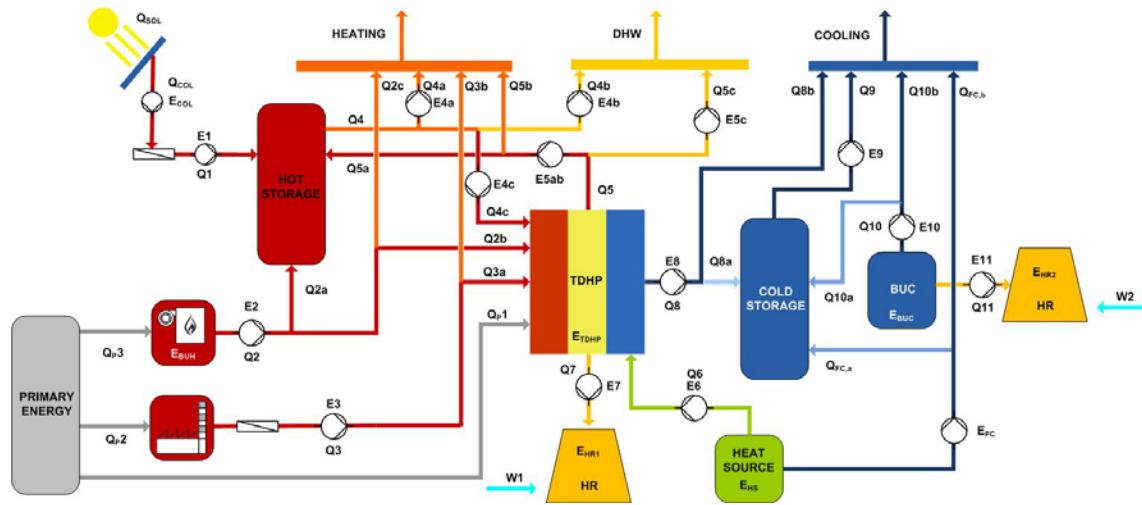

Fig. 2-2: Reference system for applications including TDHP: Modified SHC Task 38 representation (above), “Square View” (below).

System configurations – or reference system layouts – for different applications or modes of operation can be obtained from the reference system by deleting parts of it which are not used in the respective case.

Reference systems for each of the applications considered are defined in (Malenković 2012). In this report, a direct fired combined heating and cooling system is described as an example.

In the technical report (Malenković 2012), detailed flow charts for the reference cases showed in Fig. 2-3 are given. In this report, a direct fired combined heating and cooling system is described as an example.

2.2.2.3.2 Direct fired combined heating and cooling (DFCH&C)

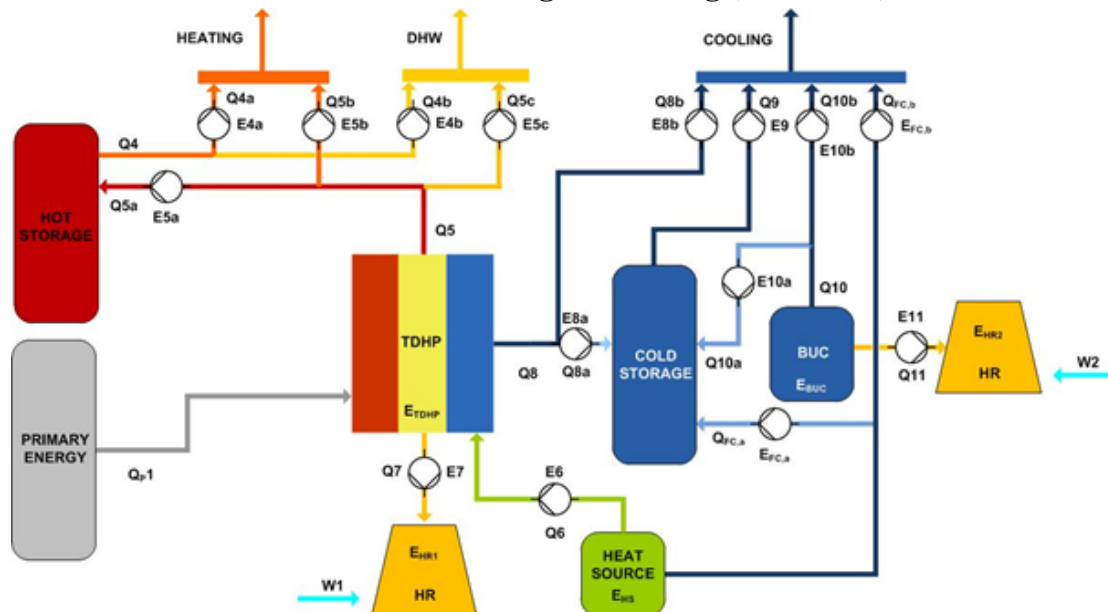

Fig. 2-3 Direct fired TDHP system for combined heating and cooling; modified SHC Task 38 representation.

In this application a thermally driven heat pump is delivering both heat and cold to the user, preferably simultaneously, to minimise the losses due to heat dissipation. Heat and the cold can be supplied directly or through a hot and/or a cold storage respectively. The system includes a heat source for the evaporator and a heat rejection unit for the heat from the absorber / condenser for the cases where the heat and the cold are not supplied at the same time. An electrically driven chiller used as back up and/or peak load can also be part of the system.

If the cold storage is fully charged or cold is not needed for a while, the energy to the evaporator can be supplied from another source, e.g. air, ground or waste water, in-ground collectors or solar energy. In the case of ground coupling or ground water, the possibility of free cooling can be considered. However, if the ground is used also for heat dissipation during active cooling operation, the temperature levels of the heat transfer medium might be too high for free cooling operation. If the hot storage is fully charged or the heat is not needed at the same time as cooling, a heat dissipation system may be needed. Generally a cooling tower would be used which can be operated as dry, wet or hybrid unit. Instead of a cooling tower, other systems are possible and in practical use – boreholes, ground water etc. They can also be designed to serve both as a heat source for heating mode only and a heat sink for cooling mode only.

In Fig. 2-4, the Square View schematic of the direct fired combined heating and cooling TDHP system is shown.

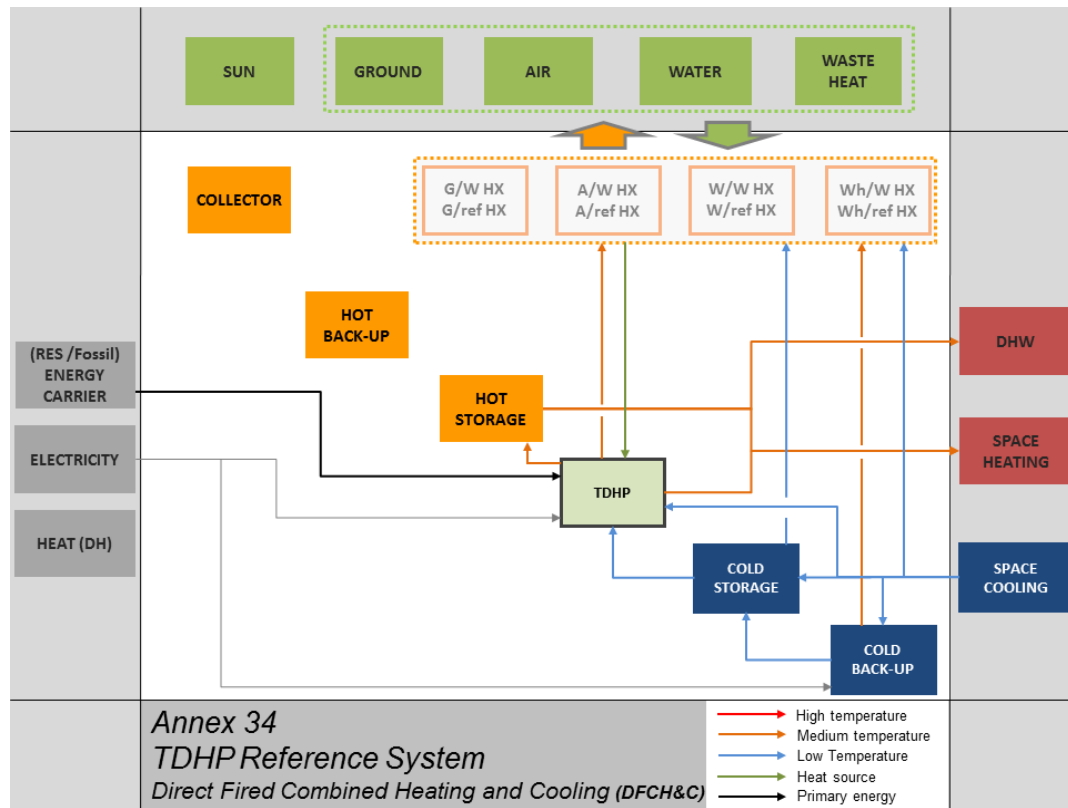

Fig. 2-4 Direct fired TDHP system for combined heating and cooling; “Square View” representation.

2.2.3 Definition of performance figures

2.2.3.1 Definition of system boundaries

For the definition of system boundaries for TDHP systems, an effort was made to propose ones which allow a fair and transparent comparison of different system configurations and technologies. This might be of interest especially for policy makers and customers, but also energy consultants and planners for example. Currently, almost every technology has its own nomenclature and definition of performance figures. Even within the same technology, different authors and normative documents tend to define different figures for a variety of often non-matching system boundaries. They may include “auxiliary” electrical energy consumption (e.g. liquid pumps, ventilators and controls), storage losses, consumption of the distribution systems etc. This inconsistency in performance reporting among different technologies and different publications is often very confusing, especially for readers without a more in-depth technical knowledge, such as most end users, policy makers etc.

When defining the boundaries, certain goals regarding the information content, universal applicability usability for different technologies and target groups were pursued. At its final stage, the work has been coordinated with a number of other international activities dealing with the same topic, but dedicated to other heat pumping technologies and/or applications: IEA SHC Task 44 / HPP Annex 38 (Malenković, Eicher et al. 2012), IEE SEPEMO (Zottl, Nordman et al. 2011) and IEE QAISt (Malenković 2012).

Five main system boundaries were defined.

1. Overall system performance including energy distribution system;
2. Overall system performance excluding energy distribution system;
3. Performance of the system without the influence of the storage;
4. Performance of each energy conversion unit including all subsystems needed for its proper functioning (heat sources and/or heat dissipation units);
5. Performance of each energy conversion unit itself, without the influence of "parasitic" energy (energy sources etc.).

A detailed explanation for the choice of boundaries and their applicability can be found in the technical report (Malenković 2012).

2.2.3.2 Performance figures

Based on a review of current normative documents for heat pumps (Malenković, Schick Tanz et al. 2012), Annex 34 proposed three different levels of performance figures, according to system boundaries:

1. Coefficient of Performance (COP) and Energy Efficiency Ratio (EER) represent the heating (COP) or the cooling (EER) capacity of the thermally driven heat pump only under stationary operating conditions, divided by the supplied driving power to the unit, including some corrections; Seasonal COP (SCOP) and seasonal EER (SEER) represent the calculated efficiencies of the unit for the same boundary as for the COP and the EER, however for defined, time dependent climatic (operating) conditions and user behaviour patterns (e.g. oscillating source temperature, changing supply temperature etc.) for a certain period of time, usually a year. All four figures are obtained from laboratory measurements under well-defined operating conditions.
2. Seasonal Performance Factor (SPF) is the ratio of the delivered useful energy to the user divided by the consumed driving energy on the system level. Different systems and sub-systems can be defined. Annex 34 proposed five main system boundaries, as described in Chapter 2.2.3.1 Definition of system boundaries.
3. Primary Energy Ratio (PER) is the ratio of the useful heating and/or cooling energy in relation to the primary energy demand. Preferably, system boundary 4 (whole system without energy distribution) should be used.

As TDHP systems generally require both thermal and electrical energy for the operation which are not equivalent in terms of exergy content, price, emissions etc., a clear distinction between a thermal performance factor and an electrical performance factor should be made, except for the PER where all energy sources are valued by their primary energy content.

Thus, the main performance figures can be defined as follows (Fig. 2-5). A detailed description is given in the technical report (Malenković 2012).

$COP_{th} = \frac{\dot{Q}_{useful,heating}}{P_{th,in,unit}}$	(1)	$EER_{th} = \frac{\dot{Q}_{useful,cooling}}{P_{th,in,unit}}$	(2)
$COP_{el} = \frac{\dot{Q}_{useful,heating}}{P_{el,in,unit}}$	(3)	$EER_{el} = \frac{\dot{Q}_{useful,cooling}}{P_{el,in,unit}}$	(4)
$SCOP_{th} = \frac{\int \dot{Q}_{useful,heating} \cdot dt}{\int Q_{th,in,unit} \cdot dt}$	(5)	$SEER_{th} = \frac{\int \dot{Q}_{useful,cooling} \cdot dt}{\int Q_{th,in,unit} \cdot dt}$	(6)
$SCOP_{el} = \frac{\int \dot{Q}_{useful,heating} \cdot dt}{\int Q_{el,in,unit} \cdot dt}$	(7)	$SEER_{el} = \frac{\int \dot{Q}_{useful,cooling} \cdot dt}{\int Q_{el,in,unit} \cdot dt}$	(8)
$SPF_{th} = \frac{\int \dot{Q}_{useful} \cdot dt}{\int Q_{th,in,system} \cdot dt}$	(9)	$SPF_{el} = \frac{\int \dot{Q}_{useful} \cdot dt}{\int Q_{el,in,system} \cdot dt}$	(10)
$PER = \frac{\int \dot{Q}_{useful} \cdot dt}{\int \left(\sum_{i=1}^n \frac{\dot{Q}_{th,in,i}}{\varepsilon_{p,i}} + \sum_{j=1}^m \frac{\dot{Q}_{el,in,j}}{\varepsilon_{el,m}} + \frac{\dot{V}_{water}}{\varepsilon_w} \right) \cdot dt}$			(11)

Fig. 2-5 Overview of the key performance figures for TDHP units and systems

Beside these more general performance figures, a number of other, system-specific figures might be used depending on the aim of the calculation. Moreover, some performance factors are component specific, e.g. the efficiency of the solar collector.

For the calculation of the SCOP and SEER, an adaption of the temperature bin method used in a number of standards for electrically driven heat pumps (e.g. EN 14825 (CEN 2011)) was discussed. Moreover, a preliminary assessment of applicability and requirements was presented within the group. Some of these considerations were used for the revision of EN 12309 (CEN 2000). Furthermore, a proposal for an extension of the temperature bin method for solar cooling systems was presented (Núñez, Malenković et al. 2011).

The definition of the PER contains a term which takes into account the energetic value of the water consumption of a system. This refers to the energy needed for the water treatment when used in e.g. wet or hybrid cooling towers. However, the definition does not take into account other environmental impacts due to water consumption.

2.2.3.3 Example: Direct fired combined heating and cooling system (

Application of system boundaries and performance figures defined in previous chapters on a TDHP system is provided for a reference direct fired combined heating and cooling system given in Fig. 2-6.

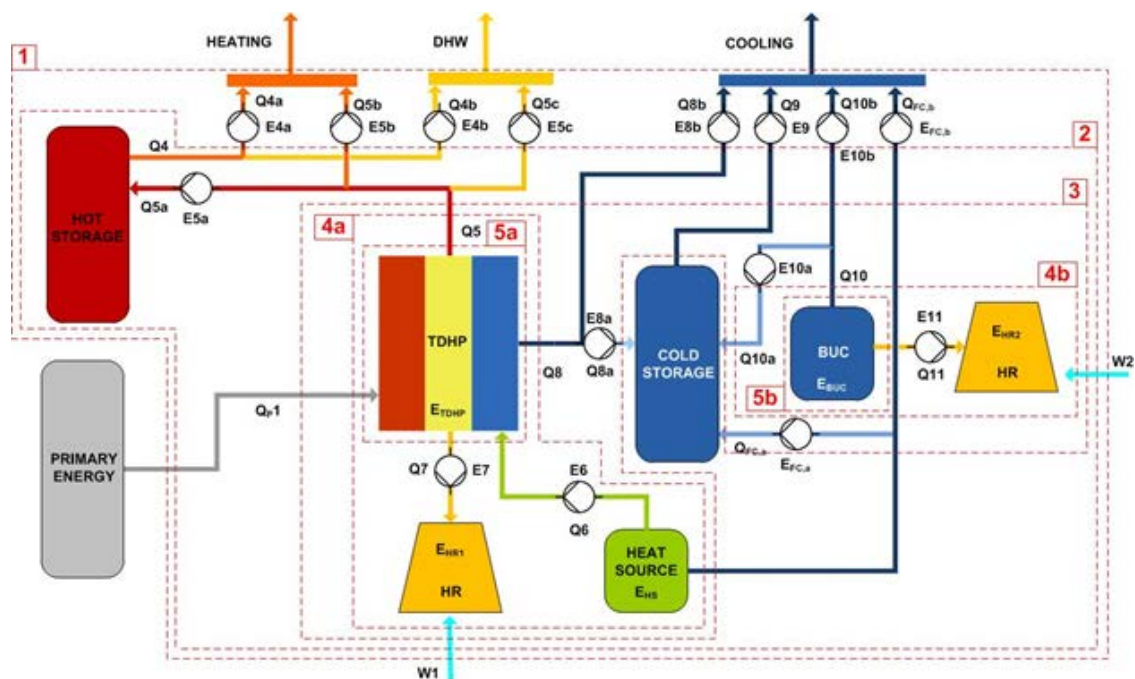

Fig. 2-6 System boundaries and energy flows of a DFHC&C-system

In case of field measurements and calculation of SPF, the correction regarding the influence of the liquid pumps is optional due to substantial effort needed to obtain measurement data needed (pressure losses, exact pump efficiency). Thus, these correction terms are provided in brackets.

System Boundary 1

Seasonal Performance Factor SPF

$$\begin{aligned}
 SPF_{th,1}^{DFCH\&C} &= \frac{Q_{SH} + Q_{DHW} + Q_C}{Q_p 1} = \\
 &= \frac{Q_{4a} + Q_{4b} + Q_{5b} + Q_{5c} + Q_{8b} + Q_9 + Q_{10b} + Q_{FC,b}}{Q_p 1}
 \end{aligned} \tag{2}$$

$$\begin{aligned}
 SPF_{el,1}^{DFCH\&C} &= \frac{Q_{SH} + Q_{DHW} + Q_C}{\sum E_{el,DFCH\&C,1}} = \\
 &= \frac{Q_{4a} + Q_{4b} + Q_{5b} + Q_{5c} + Q_{8b} + Q_9 + Q_{10b} + Q_{FC,b}}{\sum E_{el,DFCH\&C,1}}
 \end{aligned} \tag{3}$$

$$\begin{aligned}
 \sum E_{el,DFCH\&C,1} &= E_{TDHP} + E_{4a} + E_{4b} + E_{5a} + E_{5b} + E_{5c} + E_6 + E_7 + E_8 + \\
 &+ E_9 + E_{10} + E_{11} + E_{BUC} + E_{HR1} + E_{HR2} + E_{HS} + E_{FC,a} + E_{FC,b}
 \end{aligned} \tag{4}$$

System Boundary 2

Seasonal Performance Factor SPF

$$\begin{aligned}
 SPF_{th,2}^{DFCH\&C} &= \frac{Q_{SH} + Q_{DHW} + Q_C}{Q_p 1} = \\
 &= \frac{Q_{4a} + Q_{4b} + Q_{5b} + Q_{5c} + Q_{8b} + Q_9 + Q_{10b} + Q_{FC,b}}{Q_p 1}
 \end{aligned} \tag{5}$$

$$\begin{aligned}
 SPF_{el,2}^{DFCH\&C} &= \frac{Q_{SH} + Q_{DHW} + Q_C}{\sum E_{el,DFCH\&C,2}} = \\
 &= \frac{Q_{4a} + Q_{4b} + Q_{5b} + Q_{5c} + Q_{8b} + Q_9 + Q_{10b} + Q_{FC,b}}{\sum E_{el,DFCH\&C,2}}
 \end{aligned} \tag{6}$$

$$\begin{aligned}
 \sum E_{el,DFCH\&C,2} &= E_{TDHP} + E_{5a} + E_6 + E_7 + E_8 + E_{10a} + E_{11} + E_{BUC} + E_{HR1} + E_{HR2} + \\
 &+ E_{HS} + E_{FC,a}
 \end{aligned} \tag{7}$$

Primary Energy Ratio PER

$$\begin{aligned}
 PER_2^{DFCH\&C} &= \frac{Q_{SH} + Q_{DHW} + Q_C}{\frac{Q_p 1}{\varepsilon_p} + \frac{\sum E_{el,DFCH\&C,2}}{\varepsilon_{el}} + \frac{W1 + W2}{\varepsilon_w}}
 \end{aligned} \tag{8}$$

System boundary 3

Seasonal Performance Factor SPF

$$SPF_{th,3}^{DFCH\&C} = \frac{Q5 + Q8 + Q10}{Q_p1} \quad (9)$$

$$SPF_{el,3}^{DFCH\&C} = \frac{Q5 + Q8 + Q10}{E_{TDHP} + E6 + E7 + E8b + E10b + E11 + E_{BUC} + E_{HR1} + E_{HR2} + E_{HS} + E_{FC,a}} \quad (10)$$

System boundary 4a

Seasonal Performance Factor SPF

$$SPF_{th,4a}^{DFCH\&C} = \frac{Q5 + Q8}{Q_p1} \quad (11)$$

$$SPF_{el,4a}^{DFCH\&C} = \frac{Q5 + Q8}{E_{TDHP} + E6 + E7 + E_{HR1} + E_{HS}} \quad (12)$$

System boundary 4b

Seasonal Performance Factor SPF

$$SPF_{el,4b}^{DFCH\&C} = \frac{Q10}{E_{BUC} + E11 + E_{HR2}} \quad (13)$$

System boundary 5a

Coefficient of Performance COP

$$COP_{th}^{DFCH\&C} = \frac{Q5 + E5 \cdot \eta_{th,lp}}{Q_p1} \quad (14)$$

$$COP_{el}^{DFCH\&C} = \frac{Q5 + E5 \cdot \eta_{th,lp}}{E_{TDHP} + E5_{\Delta p} + E6_{\Delta p}} \quad (15)$$

Energy Efficiency Ratio EER

$$EER_{th}^{DFCH\&C} = \frac{Q8 - E8 \cdot \eta_{th,lp}}{Q_p1} \quad (16)$$

$$EER_{el}^{DFCH\&C} = \frac{Q8 - E8 \cdot \eta_{th,lp}}{E_{TDHP} + E7_{\Delta p} + E8_{\Delta p}} \quad (17)$$

Seasonal Coefficient of Performance SCOP

$$SCOP_{th}^{DFCH\&C} = \frac{Q5}{\frac{Q5}{SCOP_{on,th}} + Q_{aux}} \quad (18)$$

$$SCOP_{el}^{DFCH\&C} = \frac{Q5}{\frac{Q5}{SCOP_{H,on,el}} + E_{aux}} \quad (19)$$

Seasonal Energy Efficiency Ratio SEER

$$SEER_{th}^{DFCH\&C} = \frac{Q8}{\frac{Q8}{SEER_{on,th}} + Q_{aux}} \quad (20)$$

$$SEER_{el}^{DFCH\&C} = \frac{Q8}{\frac{Q8}{SEER_{on,el}} + E_{aux}} \quad (21)$$

Seasonal Performance Factor SPF

$$SPF_{th,5a}^{DFCH\&C} = \frac{Q5 + Q8 (+E5 \cdot \eta_{th,lp} - E8 \cdot \eta_{th,lp})}{Q_{p1}} \quad (22)$$

$$SPF_{el,5a}^{DFCH\&C} = \frac{Q5 + Q8 (+E5 \cdot \eta_{th,lp} - E8 \cdot \eta_{th,lp})}{E_{TDHP} (+E5_{\Delta p} + E6_{\Delta p} + E7_{\Delta p} + E8_{\Delta p})} \quad (23)$$

System boundary 5b

Seasonal Performance Factor SPF

$$SPF_{el,5b}^{DFCH\&C} = \frac{Q10 (-E10_{\Delta p} \cdot \eta_{th,lp})}{E_{BUC} (+E10_{\Delta p} + E11_{\Delta p})} \quad (24)$$

Note: COP, EER, SCOP and SEER can also be defined.

3 APPARATUS TECHNOLOGY

Task C of Annex 34 deals with the apparatus technology of thermally driven heat pumps and brought together the broad field of on-going developments of materials and apparatuses. Even for differing technologies like absorption and adsorption some parts of the apparatus are exposed to the same problems (closeness, corrosion, evaporator/ condenser efficiency etc.). The aim of this task was to identify the overlap between different technologies and to make synergies possible.

Within this chapter the developments of components for TDHPs are presented. The main focus was an adsorber and evaporator heat exchanger. But also a common methodology to measure and characterize adsorption materials was discussed within Annex 34. Therefore, a proposal for an adsorption material measurement procedure is described.

3.1 Adsorption components

3.1.1 Overview on adsorber developments

Intensification of the heat transfer quality in adsorbers is a key-factor for development of dynamically efficient adsorption refrigeration and heat pump systems. The different adsorber concepts proposed in literature can be essentially classified in granular (loose grains) configuration, mechanically consolidated layers, coated Heat Exchangers HEXs (see Fig. 3-1).

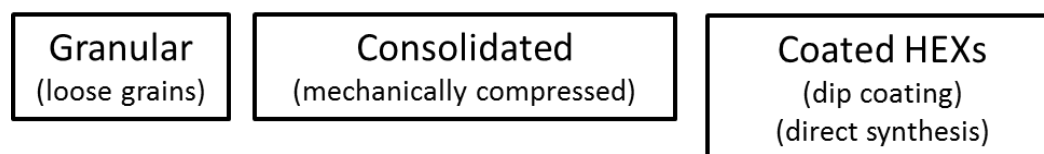

Fig. 3-1: Different adsorber concepts

Consolidation of the adsorbent material is usually achieved by mechanically compressing the adsorbent powder into a mould. Addition of highly conductive compounds (e.g. expanded graphite) is often adopted to further enhance the thermal conductivity of the adsorbent layer (Wang, Metcalf et al. 2012), (Critoph and Metcalf 2011), (Wang, Metcalf et al. 2012).

The compacted layer may be highly dense (low gas permeability) and rather thick (large pressure drops), so that this solution appears especially suitable for activated carbon/ammonia systems, where the high ammonia pressure allows to avoid limitations in the process rate (Wang, Tamainot-Telto et al. 2011).

Differently, the concept of coating the heat exchanger surface with a thin layer of active material appears appropriate for low-pressure zeolite (or silica gel)/water systems. In this case, heat transfer rate is increased by improving the thermal contact between active material and heat exchanger, rather than the thermal conductivity of the adsorbent layer itself. Proper selection of the coating density and thickness can prevent high mass transfer resistances (Dawoud 2010), (Dawoud, Höfle et al. 2010).

Many coating methods have been reported in literature, including in-situ zeolite crystallization (Bonaccorsi, Freni et al. 2006; Bauer, Herrmann et al. 2009; Schnabel, Tatlier et al. 2010), (Freni, Bonaccorsi et al. 2006), (Freni, Bonaccorsi et al. 2009) adhesive coating (Dawoud, Vedder et al. 2007) and dip coating process (Freni, Russo et al. 2007; Okamoto 2010). Direct accretion of zeolite crystals of the metal surface is a very interesting concept, as the resulting thermal contact is expected to be nearly perfect. However, in order to reach an acceptable zeolite layer thickness (> 0.1 mm), multiple depositions are necessary.

Hydrothermal synthesis of zeolite can be a quite complex and expensive process, especially for the SAPO family, which requires a long treatment in autoclave under high pressure and temperature. Moreover, one has to consider possible problems of different thermal expansion between the zeolite layer and the metal substrate due to the high temperature reached during the treatment (up to 550°C for SAPOs).

The dip-coating method represents an alternate way to deposit a thin layer of adsorbent on the heat exchanger surface. According to the techniques reported in

literature, the metal substrate is immersed into a liquid solution made of active powder and an organic (e.g. resins) or inorganic substance (Aluminium hydroxide clays, etc.), acting as a binder. A final thermal treatment is applied to remove the excess solvent, so obtaining a compact adsorbent layer. Advantage of this method is the possibility to easily vary the coating thickness in the range 0.1 – 1 mm by, for example, controlling the viscosity of the liquid solution and the dipping velocity. Experimental studies on full-scale coated adsorbers returned encouraging results, especially in terms of adsorption cycle time reduced down to a few minutes (Dawoud 2012), that can be translated to an elevated specific power.

However, the presence of binder reduces the overall sorption ability of the resulting coating and - in case of organic compounds - production of volatile substances is possible during operation of the adsorber, so altering the system pressure. The most simple (and cheap) adsorber concept consists of the embedding of adsorbent grains between the fins of the heat exchanger. It is self-evident that the adsorbent granules present intrinsically poor heat transfer properties. However, recent experimental data demonstrated that a granular adsorber can provide acceptable performance when small-size grains (< 0.5 mm) and extended surfaces heat exchangers (> 1000 m²/m³) are employed (Grisel, Smeding et al. 2010; Sapienza, Santamaria et al. 2011).

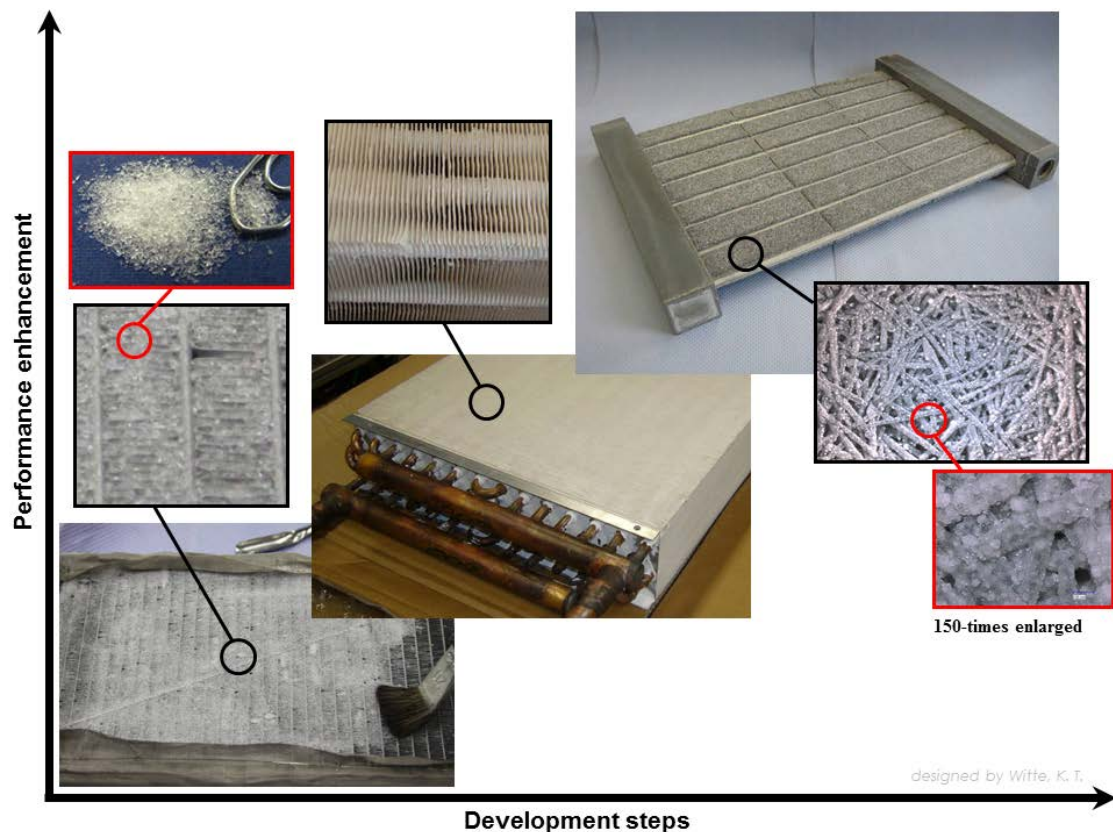

Fig. 3-2: Different evolution steps of the performance enhancement in adsorber development: Packed-bed heat exchanger (left), binder based dip-coated lamella heat exchanger (centre) and direct crystallisation connection of the sorbent (right) on 3D-metal structure heat exchanger. Source (Schossig P. 2011)

Fig. 3-2 illustrates the performance enhancement of the adsorber heat exchanger in several development steps (Schossig P. 2011). The left-hand photo shows an automotive cooling unit used to create a packed bed adsorber where the sorbent is prevented from falling out at the bottom by a wire mesh, and a brush helps to fill in the sorbent very closely. Although the volume specific density (sorbent per volume) is very high in this case, the thermal connection between the sorbent and the heat exchanger fin is fairly poor, hindering the released heat (arising by adsorption of the water molecules on the adsorber) to flow from the granules to the heat transfer fluid. The reason is that there exists ‘at most’ two point contacts per sphere only between the sorbent (sphere) and the heat exchanger fin (the fin gap is greater than sphere’s diameter) and the remaining surface area of the sphere has to face a higher thermal resistance (air gap) while transporting the released heat to the fins. To overcome this, for example a binder based dip coating of the lamella heat exchanger can be applied as next step (centre). Here, a uniform connection is realised all over the heat exchanger and only small air gaps (if any) exist between sorbent and fin. Finally, a direct crystallisation connection, as can be seen in the right hand photograph (150 times enlarged), can be done on top of a metallic short fibre structure (sinter-fused structure), giving an enormous increase of surface area (3-D) (Füldner, Schnabel et al. 2011). This combination provides both good thermal conductivity in the metal and an excellent sorption-material-to-metal-mass ratio.

3.1.2 Adsorber characterization

The development of binder-based coated AdHEX represents one of the most recent techniques proposed for the improvement of adsorption heat pumps or chillers performance, as it allows the possibility of enhancing both heat and mass transfer characteristics of the AdHEX , (Okamoto 2010).

In order to evaluate the benefit achievable, the analysis of the small scale kinetic performance of different proposed configurations is mandatory (Aristov 2009). In the following sections, an example of the preparation of coated samples and their kinetic characterization are reported.

A loose-grain case is also reported for comparison purpose.

3.1.2.1 Samples preparation

Basically, the coating is made of three components: an active material (adsorbent), a binder and a filler. A SAPO 34, with chabazite framework, was selected as adsorbent material. The choice of such material is due to its ability to be regenerated at low temperature (80-90°C), maintaining high adsorption capacity, especially if compared to other commercial adsorbent materials commonly used in these applications (e.g. silica gel) (Okamoto 2010). Subsequently, an intensive experimental activity was carried out, in order to identify the optimized formulation of the coatings with particular attention paid to their mechanical stability. The binder was selected among the class of clays. In fact, proper clay should guarantee a highly porous structure, showing a good ability to be permeated by the water vapour at the low pressures typical of the operating conditions of the adsorption machines. The need of using a filler derives both from the idea of improving the mechanical stability of the coating itself, and also of increasing the thermal conductivity of the layer.

The preparation of the samples consists of three main phases. First of all the three components (adsorbent material, binder and filler) are mixed together in aqueous solution, and mechanically stirred to obtain homogeneous slurry. The amount of employed water depends on the thickness of the layer that has to be obtained, as it derives directly from the viscosity of the slurry. Afterwards the samples are prepared by means of a dip coating technique. Before the dipping phase, the surface of the flat aluminium substrate is pre-treated by means of sandpaper, in order to increase its roughness, and then carefully cleaned with acetone. Finally the coated samples are dried for 24 h at ambient conditions, and afterwards are calcinated for 24 h at 450°C, to obtain the consolidation of the adsorbent layer. In Fig. 3-3 two phases of the sample preparation are reported.

In conclusion, the optimized configuration of the coating is based on the SAPO 34 adsorbent, bentonite clay as binder and micro carbon fibres as reinforcement filler.



Fig. 3-3: Preparation of the coated samples: dip coating phase and consolidate layer after calcination.

As the aim of the work was the evaluation of the kinetic properties of the coating, samples having different thicknesses of the active layer were prepared, in order to evaluate its influence on the achievable kinetic properties. As already mentioned, the thickness of the coated samples was varied by tuning the amount of water employed during the slurry preparation.

3.1.2.2 Setup for adsorption kinetic measurements

The adsorption kinetic properties of the samples were experimentally evaluated by means of an adsorption kinetics test facility available in the labs of the Fraunhofer ISE in Freiburg, Germany. The following Fig. 3-4 shows a scheme of the complete kinetic measurement apparatus. The kinetics test facility consisted of two different chambers that might be connected and disconnected by valves. The measuring chamber contained the sample fixed on the cold plate. The other chamber was used as the water vapour reservoir and the dosing chamber. In order to avoid condensation and to realize reproducible ambient conditions, both chambers were located in a large box kept at constant temperature (40°C). Connecting the dosing chamber with a water vapour source at a given temperature, the equilibrium water vapour pressure at this temperature could be attained. Upon closing the valve between this chamber and the

water bath (valve 2), the total mass of water vapour in the chamber could be estimated through an equation of state. For water vapour at low pressures, the calculation was performed by using the ideal gas law.

The pressure was measured inside both chambers by capacitive sensors (MKS Baratron 628) with a range of 1–10,000 Pa with a resolution of 1 Pa. Temperature of the surface of the samples was measured by means of an IR sensor, placed outside the chamber. It was chosen due to its highly dynamic response. A computer was used for data logging and controlling the experiment.

Before the uptake measurements were performed, the samples were desorbed with similar pre-conditioning, resulting in comparable starting conditions. The basic steps of the isothermal measurements are given in Table 3-1. Two different strategies of desorption were employed. In both cases the sample was heated to 95 °C, but in the first case the measuring chamber was evacuated against the vacuum pump until pressure and temperature signal stayed constant for about 3h, instead, in the second case, the measuring chamber was connected to the water reservoir thermostat, which acted as a condenser, maintained at 30°C.

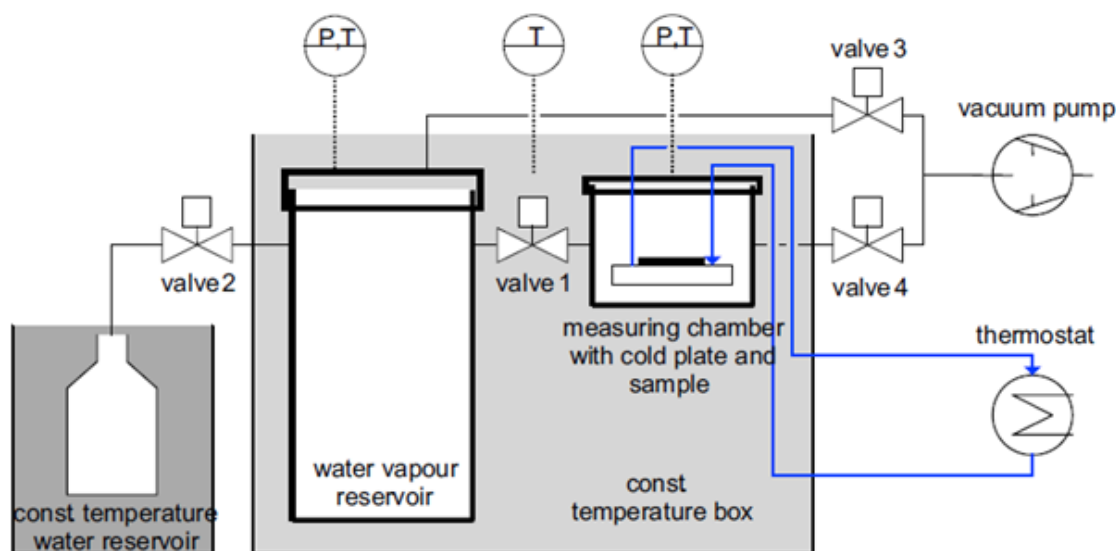

Fig. 3-4: Scheme of the entire kinetic measurement setup.

Fig. 3-5 shows a scheme of the integration of the measured sample inside the testing chamber. The coupling between cold plate and aluminium substrate can be achieved either by means of a screw based pressing system or by means of a removable heat conductivity paste (Thermigrease TG20031). Likewise, the system can be also equipped by a heat flux sensor, placed between the sample and the cold plate. During the measurements the cold plate is cooled by water flowing at a high rate at constant temperature, and thus providing an isothermal condition on its surface.

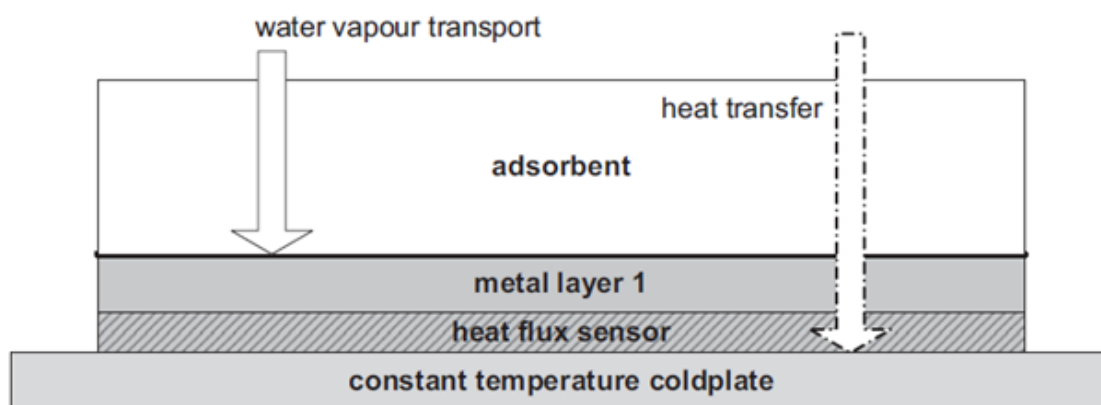

Fig. 3-5: Integration of the sample inside the testing chamber.

Obviously, using the first method of desorption, the initial loading of the sample is not known, but tends to be very close to zero due to the combination of heating and evacuation. On the contrary, more realistic initial conditions are determined by desorption done by heating and condensation at the given temperature. In fact, the initial loading represents a final state of desorption cycle and can be calculated, if equilibrium data are available.

Table 3-1: Basic steps of the isothermal measurements.

Step of measurement	Temperature/pressure	Demands
Desorption	95°C/<1 Pa 95°C/ ≈4200 Pa	Temperature and pressure were constant for 3 h
Cooling	40°C	Measuring temperature of 40°C was constant for 1h in cold plate and thermo box
Preparing the dosing chamber	≈2300 Pa	2300 Pa corresponds to 20°C evaporator temperature
Adsorption	40°C	Measurement was performed until heat flux signal returned to starting value or there was no more pressure decrease

The second step of pre-conditioning involved the cooling of the sample until the desired temperature was attained and remained constant for 30 minutes. Simultaneously, the water vapour reservoir was prepared. The water reservoir thermostat was set to the temperature corresponding to the desired vapour pressure. Once the temperature was attained, valve 2 was opened and the water vapour flowed into the reservoir, which had been evacuated before.

After this preparation phase, the sample was ready and the test could be carried out. The measurement started by opening the connection (valve 1) between the measuring chamber and the water vapour reservoir used as the dosing chamber. The sample instantaneously started to adsorb and consequently the measured pressure decreased. Data logging was performed until the pressure became constant. In a subsequent data processing step the amount of water uptake was calculated by assuming that a decrease in pressure could be attributed directly to an increase in the amount of adsorbed water. The initial amount of water was calculated by using the ideal gas law and the initial pressure, temperature and volume of the dosing chamber. In order to

evaluate also the percentage of water uptake, the dry mass of the samples was measured by means of an external thermo-gravimetric system.

3.1.2.3 Results and discussion

For comparison purposes, kinetic tests were performed on the three coated samples above described and on another sample which reproduces the typical multilayer configuration, achieved when loose grains of adsorbent material are put in contact with the HEX by means of a metallic net.

The following table reports the characteristics of the different tested samples.

Table 3-2: Characteristics of the different tested samples.

Sample	Thickness [mm]	Covered Surface [cm ²]	Deposited dry weight [g]	Dry weight/Covered Surface Ratio [kg/m ²]
BEN-1	1.1	15.07	0.8549	0.5672
BEN-2	0.83	15.96	0.6608	0.414
BEN-3	0.61	16.08	0.4585	0.2851
Multilayer of loose grains	-	25	0.8154	0.3261

For each sample two different adsorption tests were carried out, changing the regeneration conditions. A heat conductive paste was used to minimize the contact thermal resistance between the cold plate and the metal substrate of the sample.

The following Fig. 3-6, Fig. 3-7 and Fig. 3-8 resume the main results obtained from the kinetic tests.

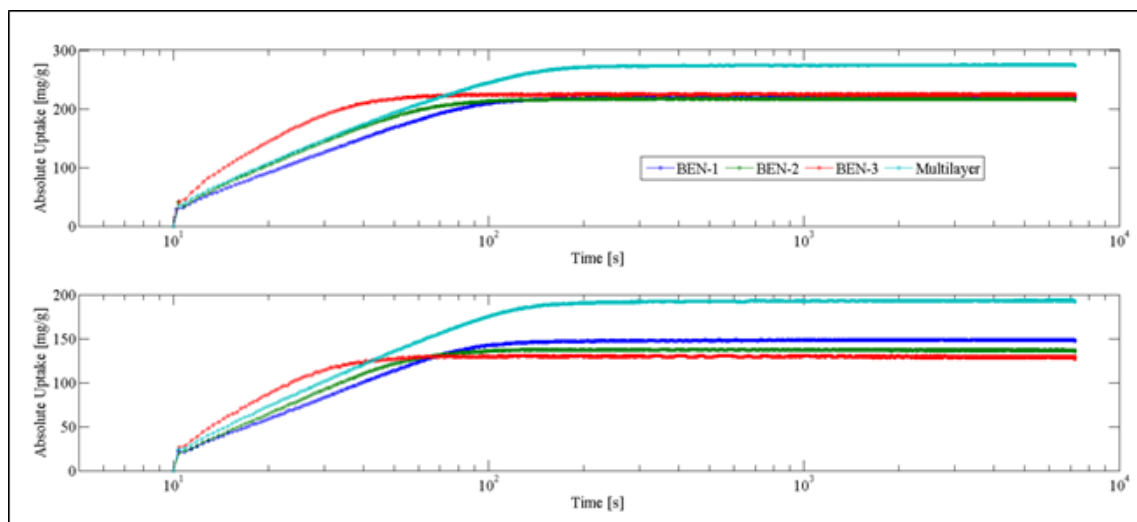

Fig. 3-6: Dynamic evolution of the absolute uptake of the four tested samples: in the upper part after desorption against the vacuum pump, in the lower part after desorption against the condenser @ 30°C.

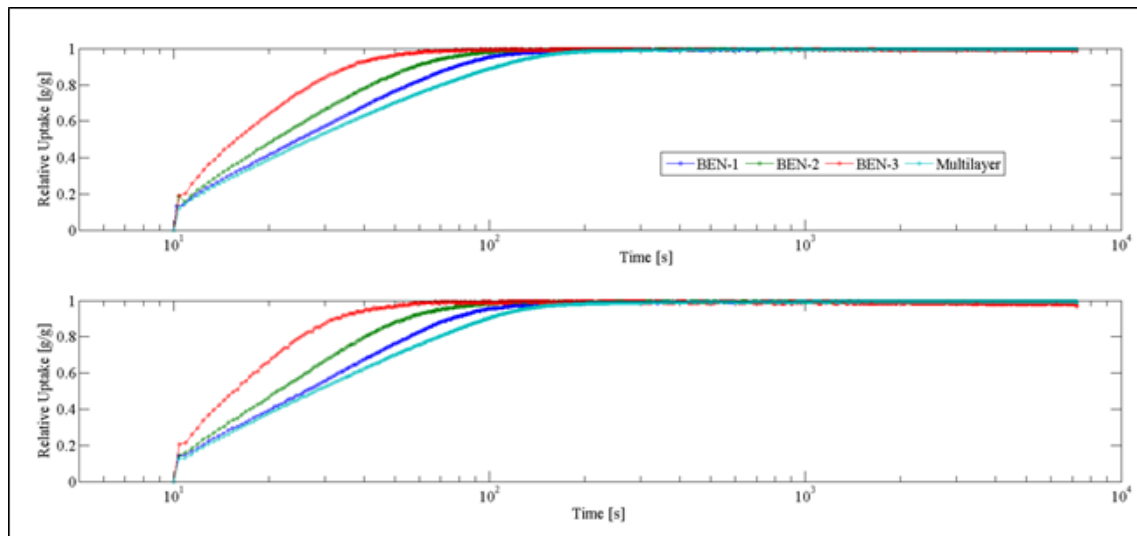

Fig. 3-7: Dynamic evolution of the relative uptake of the four tested samples: in the upper part after desorption against the vacuum pump, in the lower part after desorption against the condenser @ 30°C.

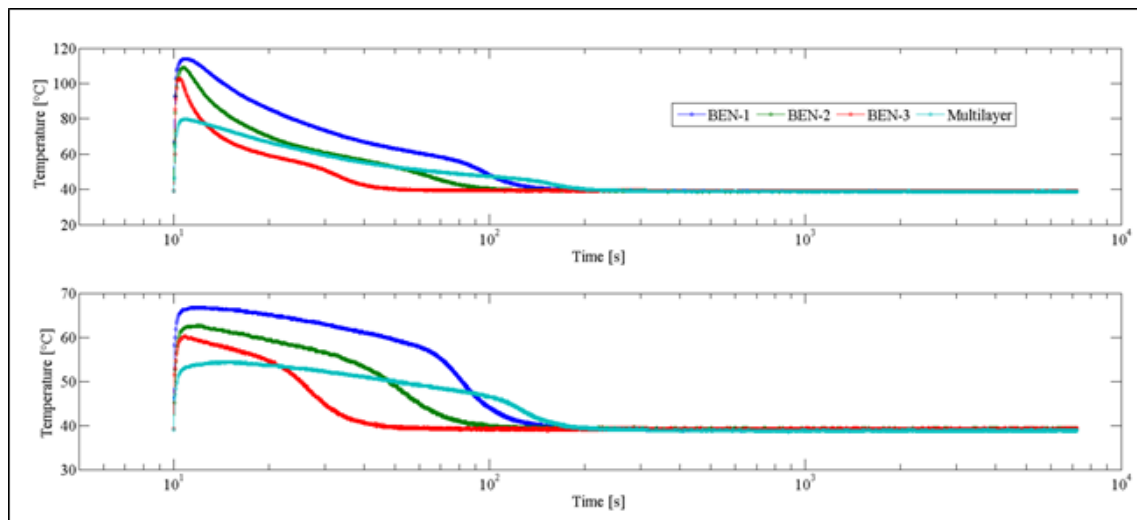

Fig. 3-8: Dynamic evolution of the surface temperature of the four tested samples: in the upper part after desorption against the vacuum pump, in the lower part after desorption against the condenser @ 30°C.

In each figure both the measurements conducted for desorption against the vacuum pump and against the condenser are reported. The evolution of the absolute water uptake per dry mass shows that, as expected, the highest value is reached for the multilayer configuration, as it is composed of pure adsorbent material. In fact, the presence of the binder in the coated samples affects the absolute water uptake achievable. Analysing the evolution of the relative uptake, which is evaluated as the ratio between the actual uptake to the maximum uptake reached at equilibrium, it is easy to notice that the coated samples show faster equilibrium time compared to the multilayer configuration. In particular the kinetic properties are almost the same both for the tests carried out with desorption against condenser and against vacuum pump and, as expected, the thinner coated sample shows a faster kinetic compared to the thicker one.

Finally, the evolution of the surface temperatures demonstrates that the coating technique increased the overall thermal transfer properties of the sample. Actually, during the first instants of the adsorption process, the surface temperature of the coated samples rise up faster than the multilayer configuration, and, after reaching the higher temperature value, it decreases until getting the cold plate temperature, quicker than the multilayer one. In particular, the thicker layer shows the maximum reached temperature, which is related to the higher quantity of adsorbent material which releases a relevant amount of heat, mainly during the first instants of the process.

In order to better evaluate the kinetic performance of each sample, some parameters, usually reported in literature (Dawoud and Aristov 2003), have been calculated, namely, the time needed to reach the 50% of adsorption, $\tau_{0.5}$, the time needed to reach the 90% of adsorption, $\tau_{0.9}$, and the rise-up time, $\tau_{0.8}$ - $\tau_{0.15}$. The following Table 3-3 resumes all these data.

Table 3-3: Characteristic times obtained on the tested samples.

Sample	$\tau_{0.5}$ [s]	$\tau_{0.9}$ [s]	$\tau_{0.8}$ - $\tau_{0.15}$ [s]
BEN-1	16.3	65.9	44.9
BEN-2	11.4	44.4	31.5
BEN-3	5.9	22.4	17.1
Multi-Layer	97.5	174.3	59.5

It is possible to appreciate how the decreasing of the calculated characteristic times shows a linear correlation to the decreasing of the thickness of the coatings.

In order to obtain a better estimation of the ideal performance achievable by each tested configuration, the specific cooling power was evaluated. Of course, the adsorption process simulated by means of the kinetic apparatus is quite different from the real operating conditions of an adsorption heat pump or chiller. In fact the driving force which promotes the adsorption of the water vapour from the evaporator is a temperature drop. The kinetic apparatus used for these measurements, usually simulates an adsorption phase promoted by a pressure drop, at constant temperature (method commonly known as LPJ (Dawoud and Aristov 2003)). However, for comparison purposes, it is possible to use the specific cooling power as parameter.

The specific cooling power (SCP) is defined as follows:

$$SCP = \frac{h \cdot w}{\tau_{ads}} \left[\frac{W}{g_{ads}} \right]$$

Where h [J/g] represents the latent heat of evaporation of water (which was taken as 2478 J/g), w [g_{water}/g_{ads}] is the relative uptake and τ_{ads} [s] is the duration of the adsorption phase.

The following Table 3-4 summarizes the SCP calculated for each sample configuration, assessed at the adsorption time correspondent to the 80% of the total uptake achieved

Table 3-4: Specific Cooling Power [W/g] evaluated for the tested configuration (desorption against condenser).

Sample	SCP [kW/kg _{ads}]
BEN-1	6.45
BEN-2	9.02
BEN-3	16.98
Multi-Layer	6.48

The evaluated SCP values result to be higher than that reported in literature, on the same material, tested in a monolayer configuration by means of a kinetic apparatus working with temperature drops (about 2.3 kW/kg_{ads}) (Aristov 2009). Actually a direct comparison between the different results is not correct, because of the really different testing conditions employed.

Moreover, also the performance achievable by the four different proposed configurations in a real AdHEX was calculated. For this purpose the geometrical parameters (reported in Table 3-5) of a common aluminium finned flat-tube HEX were used as reference.

Table 3-5: Geometrical characteristics of the reference HEX.

Dimensions [mm]	257 x 170 x 27
Metal mass, M [kg]	0.636
Volume, V [m ³]	1.1 10 ⁻³
Heat transfer surface [m ²]	1.66
Ratio S/V [m ² /dm ³]	1.51
Ratio S/M [m ² /kg]	2.61

Accordingly, both the volumetric and specific cooling power for the chosen AdHEX configuration were calculated. The following table reports the evaluated performance.

Table 3-6: Estimated volumetric and specific cooling power for the four AdHEX configurations.

Configuration	SCP [kW/kg _{adsorber}]	VCP [kW/dm ³ _{adsorber}]
BEN-1	3.85	5.52
BEN-2	4.68	5.64
BEN-3	7.24	7.31
Multilayer	2.98	3.19

The obtained results demonstrate the improvement of the performance achievable passing from the multilayer unconsolidated configuration to the coated ones. Moreover, both the volumetric and specific cooling power increase by reducing the thickness of the coating, so that it might be expected that further reduction of the amount of deposited material could get more effective the overall performance of the AdHEX.

3.1.3 Evaporator developments

The evaporator is the heat exchanger that connects the chilled water circuit to machines part where ‘cold’ is effectively produced through the evaporation of refrigerant. Two major principles exist in the design of the evaporator heat exchangers: falling film and pool boiling evaporators.

Fig. 3-9 shows a tube bundle immersed into a pool as well as a corresponding cross sectional view for two cases. Left hand describes the pool boiling case at a low filling level – typically the tubes are entirely immersed - where the refrigerant (blue) is supplied from the bottom. In contrast the falling film concept is explained via the illustration on the right hand.

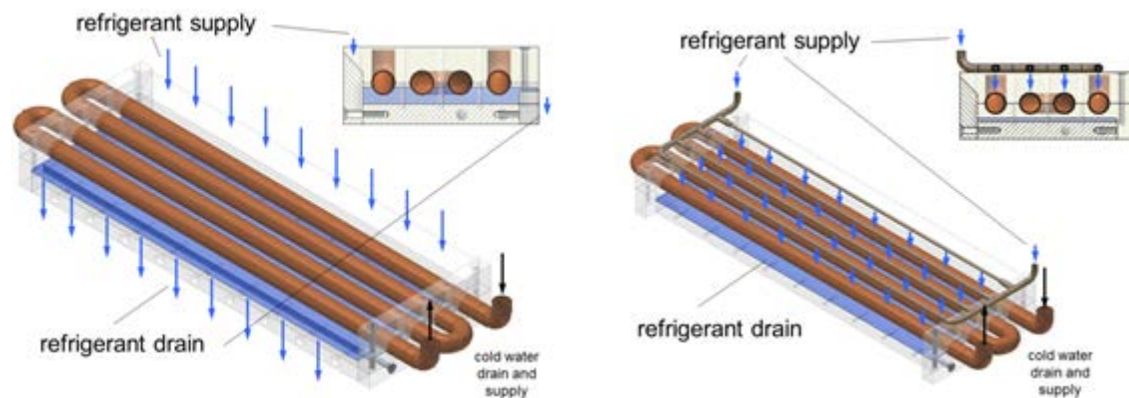

Fig. 3-9: Comparison of pool boiling at a low filling level (left) versus falling film evaporation (right) as investigated in the SORCOOL project at Fraunhofer ISE.

As the ab- or adsorber reduces the pressure of the refrigerant which yields to a saturation temperature below the chilled water temperature, heat flow between the chilled water (high temperature) and the refrigerant inside the evaporation pool (low temperature) is possible. Refrigerant and chilled water are separated via a solid tube wall. The heat flow driven by the temperature difference is dependent on the heat resistance between the two temperature levels. This heat resistance (R) consists of five individual resistances as they are expressed through the second formula in Fig. 3-10 and may contain the following transport mechanisms.

- Heat transfer between the chilled water and the tube (surface and flow regime dependent)
- Heat conduction through the tube wall (material dependent)
- Heat transfer from the tube to the water
- Heat conduction and convection through the water layer and finally
- Heat transfer from the top of the water

While the last three items significantly depend in turn on the boiling region. Thus, if nucleate pool boiling is reached for example, the phase change from water to water vapour directly occurs at the tube wall.

In order to reach energy efficient systems pump energy is to keep as low as possible. Typically, conduction through the tube is high (as copper or stainless steel is used as

heat exchanger material). The heat transfer between tube wall and refrigerant and between tube wall and chilled water circuit are limiting the overall heat transfer. There are two possibilities to improve the overall heat transfer between the chilled water circuit and the refrigerant. The surface area could be increased or the heat transfer coefficient can be improved.

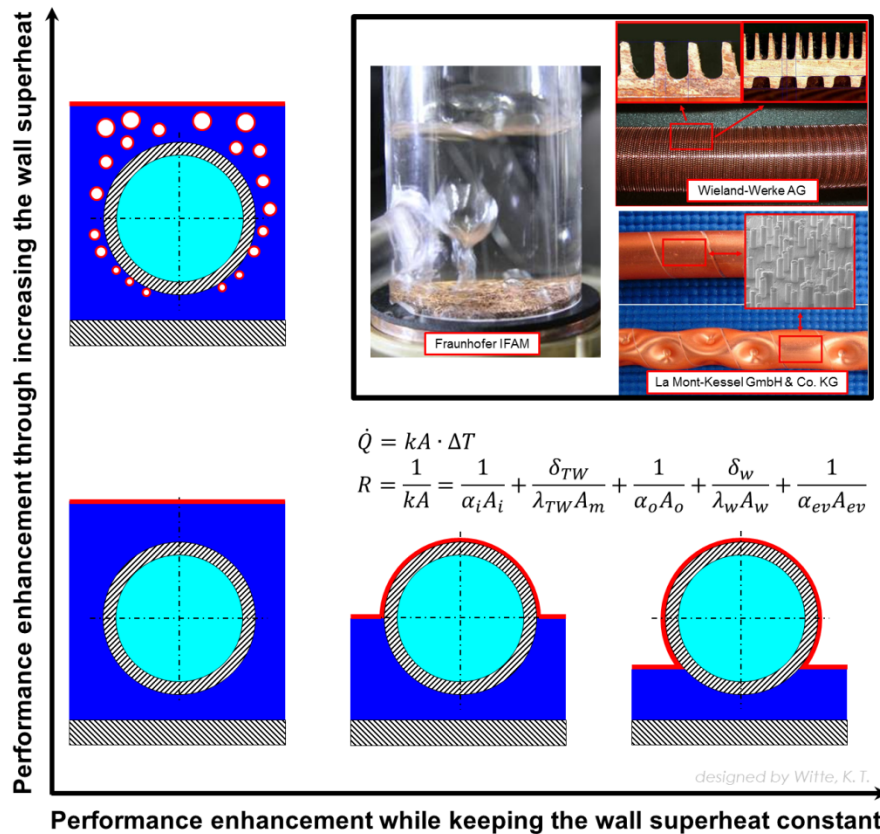

Fig. 3-10: Enhancement technics to increase the outer heat transfer of an immersed tube and a cut-out with pictures of nucleate pool boiling at a 3D-metal structure manufactured by Fraunhofer Institute for Manufacturing Technology and Advanced Materials (IFAM) on the left hand as well as high performance evaporation tubes from the manufacturers Wieland Werke AG (top right) and La Mont Kessel GmbH & Co. KG with a surface treatment by MiCryon Technik GmbH (bottom right).

Improving the heat transfer alongside the cross-sectional area of a tube - as regarded in Fig. 3-10 - each participating resistance is to lower. For the heat transfer between chilled water and tube wall well known options are increasing the volume flow inside the tube or inserting turbulent flow generators. To lower the resistance of the tube wall materials with high thermal conductivities as well as huge contact areas on both sides are to apply. Observing the resistances outside the tube appropriate options are visualised in Fig. 3-10. Thus, it is either possible through reaching the boiling regime of nucleate boiling (cf. top left) or to lower the thickness of the water layer in the region of convective boiling (cf. horizontal axis). As cooling application require low temperature differences between chilled water stream and the refrigerant inside the evaporation pool high performance surfaces are required to reach the region of nucleate boiling at already little wall superheats. Left hand side of the cut-out in Fig. 3-10 shows such a high performance 3D-metal structure where the initiation of nucleate boiling has been observed at wall superheats of already 8 K at a pressure of

10 mbar. Lowering the thickness of the water layer (cf. horizontal axis) – which simultaneously increases the area of free surface evaporation (cf. red layers) - is beneficial as it has a direct impact on heat transfer already at low wall superheats. Tube wetting is reached through capillary surface structuring where water moves upwards automatically. The cut-out in Fig. 3-10 shows high performance evaporation tubes able to make use of this capillary-assisted-evaporation where ‘art exists’ in ensuring a continuous tube wetting during the operation. Additionally, these pictures show turbulent flow generators realised through internal fins (top) and a tube deformation (bottom). Both combinations result in a high tube performance. Thus, performance enhancements of up to factor 14 could have been observed in comparison to a plain reference tube. Therefore, higher pressure drops inside the cold water stream require an additional pump energy input and are to respect while designing the evaporator.

Applying falling film evaporation which is as well accompanied by thin water layers and additionally uses the benefit of forced convection is also well-known to increase the heat transfer. Nevertheless, moving parts and the electrical energy input to run the refrigerant pump are to consider. Thus, the question is whether the energy conservation through the use of a more compact and therefore less ‘pressure drop consuming’ evaporator exceeds the electrical energy input to run the refrigerant pump or not. For further information see:

- (Witte, Schnabel et al. 2009)
- (Schnabel, Witte et al. 2011)
- (Witte, Schnabel et al. 2011)
- (Witte, Dammel et al. 2011)

3.2 Characterisation of adsorption materials

For further improvement of adsorption type TDHPs it is of importance to identify useful working pairs and to measure their physical properties. Many working groups in different research institutes are working in this field. In order to compare the measurement results and to find the working pair best fitting to a certain application it is of importance to have common methodology. Within this annex such a procedure is proposed.

3.2.1 General overview

The characterisation of adsorption materials is in the focus of many publications e.g. (Srivastava and Eames 1998), (Aristov, Restuccia et al. 2002), (Janchen, Ackermann et al. 2002), (Critoph and Zhong 2005), (Henninger, Schmidt et al. 2010). Three possibilities exist to measure the ability of adsorption materials.

The most frequent measurement method used is thermogravimetry (TGA) and volumetry. Mainly nitrogen is used as inert gas under a well-defined temperature-scanning rate in TGA. However, also the material as to be prepared before the measurement takes place. Unfortunately the shape of the curve and therefore the differential thermogravimetric (DTG) signal to determine the temperature on set point for the released water strongly depends on the used heating rate. Furthermore comparison of materials measured with this method leads to large discrepancies as the

initial state, which is room temperature, is not well defined and therefore difficult to reproduce. In addition without a possibility to perform adsorption curves, possible hysteresis effects cannot be detected.

Another possibility in case of open systems is to use a well-defined humidified carrier gas (e.g. Setaram WetSys) which flows around the sample. To prevent condensation, the transfer line and the measurement cell has to be temperature controlled in an accurate way.

The third possibilities are systems with closed working fluid atmosphere. As shown in (Henninger, Schmidt et al. 2010) measurements with open and closed systems are comparable if using the same reference conditions. These influencing factors have to be taken into account in order to define a common procedure (see Fig. 3-11).



Fig. 3-11: Influencing factors for thermal analysis of the adsorption characteristics.

Beside the differences in the apparatuses an additional barrier is the difference in isobaric versus isothermal measurements. Isothermal measurement in principle allows the determination of the heat of adsorption, by calculation for at least two isotherms or direct measurement within a simultaneous TG/DSC. In addition, especially with regard to the Dubinin transformation, the temperature independency can be verified.

Isobaric measurement can in principle be performed in a broader temperature range therefore covering a larger range of the adsorption potential $A = RT \ln p/p_0$. Furthermore as the real cycle (ideally) consists of two isobaric phases of desorption and adsorption at condenser and evaporator pressure, the isothermal measured data is not directly adoptable to the operating device.

3.2.2 Proposed procedure

As a result of the consideration described above a common method for determination of water adsorption characteristics with focus on adsorption heat pumps and chillers has been developed (Henninger, Freni et al. 2011).

The procedure consists of a pre-treatment of the sample under continuous evacuation (vacuum level: $1e^{-4}$ kPa). The optimal sample pre-treatment temperature should be selected according to the following classification.

- Strongly hydrophilic zeolites (4A, 13X): pre-treatment $T = 300^{\circ}\text{C}$.
- Hydrophilic aluminosilicates (NaY): pre-treatment $T = 200^{\circ}\text{C}$

- Hydrophobic aluminosilicates (silicalites, ZSM5): $T=150^{\circ}\text{C}$
- Aluminophosphates (AIPO, SAPO): $T=150^{\circ}\text{C}$
- Others (silica gels, activated carbons): $T=150^{\circ}\text{C}$

The sample is heated starting from ambient conditions with a heating rate of $1\text{K}/\text{min}$ followed by an isothermal drying step for another 8 hours. In the following step, isobar measurement at a water vapour pressure of 1.2 and 5.6 kPa takes place.

The selection of the two pressure levels is motivated with respect to the possible applications. The pressure level of 1.2 kPa corresponds to an evaporation temperature of 10°C , which marks a useful temperature level for cooling applications. The second pressure level of 5.6 kPa corresponds to 35°C which either marks the temperature where heat can be rejected (cooling application) or can be used for low temperature heating (heat pumping application). For each pressure level the sample temperature is varied in 5 or 10 K steps between 150°C and 40°C (for 5.6 kPa) or 20°C (for 1.2 kPa) respectively. In addition at least one adsorption and desorption measurements should be performed in order to detect possible hysteresis effects.

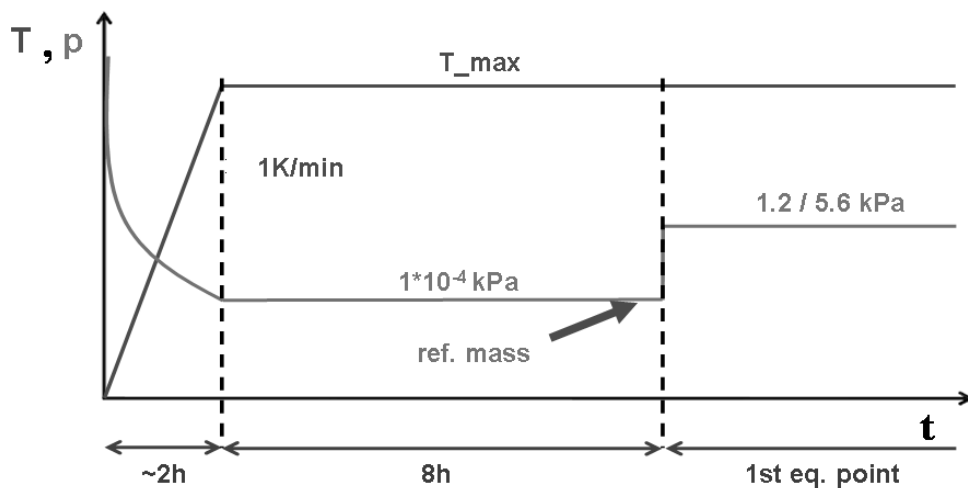

Fig. 3-12: Proposed measurement procedure, including sample pre-treatment and the first isobaric step.

3.2.3 Results

3.2.3.1 Comparison on Silica Gel 127 B

In a first step, the proposed procedure has been successfully verified by measuring water adsorption characteristics on a standard Silica Gel 127 B from Grace.

The measurement at ITAE has been performed with a Cahn thermobalance whereas the measurements at ISE have been performed on a Rubotherm thermobalance. Both apparatus are connected by a heated transfer line to an evaporator in order to maintain fixed water vapour pressure over the sample.

The water adsorption and desorption isobars at 1.2 kPa in direct comparison are showing Fig. 3-13. Although some points are not exactly in equilibrium, the overall

agreement between ITAE and ISE isobar adsorption measurement with the above described procedure is excellent. The desorption isobars are also in good agreement for higher temperatures whereas for lower temperatures and higher loadings there is a significant difference. This is probably a combination of non-equilibrium state and small hysteresis.

The water adsorption and desorption isobars at 5.6 kPa in direct comparison are shown in Fig. 3-14. Again the agreement between the equilibrium points measured in similar conditions at CNR-ITAE and at Fraunhofer-ISE is excellent.

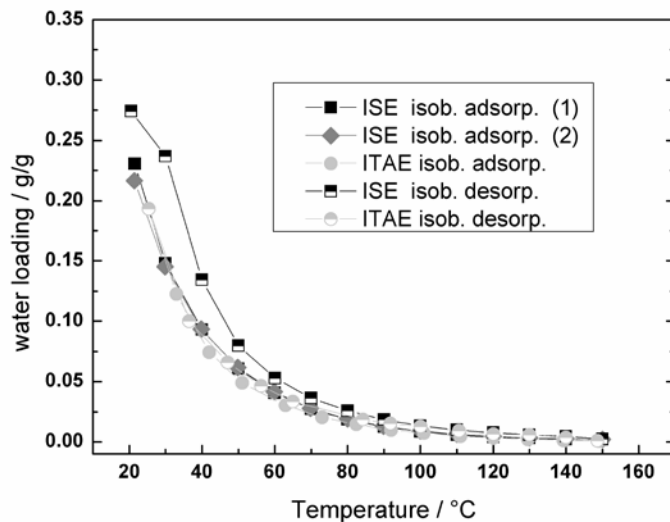

Fig. 3-13: Comparison of isobar adsorption measurements for Silica Gel 127 B at 1.2 kPa.

As result of these measurements, a water uptake for an adsorption chiller working under the conditions (30°C/1.2kPa adsorption versus 100°C/5.6 kPa desorption), which are typical values, can easily be taken from the measurement data and accounts to 127 g/kg.

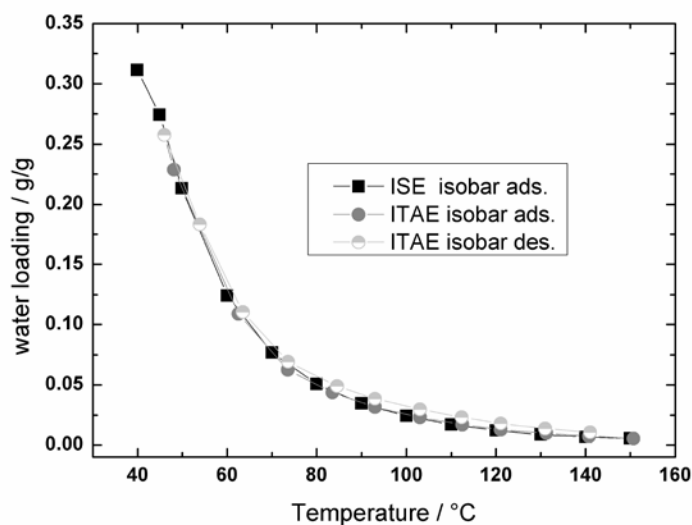

Fig. 3-14: Comparison of isobar adsorption and desorption measurements for Silica Gel 127 B at 5.6 kPa.

Concerning the possible utilization of the silica gel 127B as water adsorbent in adsorption chillers driven by low temperature heat ($T < 100^{\circ}\text{C}$), the following remarks can be done.

First, a large part of the adsorbed water can be released at a regeneration temperature of about 100°C , without noticeable hysteresis effects. Second, a maximum water loading “at equilibrium” is rather high (0.2-0.3 g/g, depending on the imposed vapour pressure). However, a high relative pressure ($p/p_s = 0.5-0.7$) is required to reach such elevated levels of saturation, which is not favourable for application in adsorption heat transformers.

3.2.3.2 Comparison on SAPO-34

In addition to the first results on the Silica Gel another material out of the class of the silica-aluminophosphates has been used for comparison. Unlike the Silica Gel the SAPO-34 shows a quite different adsorption characteristic with an S-shaped adsorption isotherm within a narrow relative pressure. This shape is advantageous for the application in adsorption heat transformers.

The adsorption and desorption measurements for 1.2 kPa are shown in Fig. 3-15. Again there is a good agreement between the measurements although the applied pressure was slightly different (1.2 vs. 1.1 kPa). For very high loadings again there is a difference for the adsorption path, whereas the desorption path is in excellent agreement.

It has to be mentioned, that the ISE measurements have been performed in an open flow system TG-DSC by Setaram. As there is no possibility for evacuation of the system, the sample pre-treatment was different. For determine the reference mass, the sample has been dried at 150°C under a pure carrier gas flow.

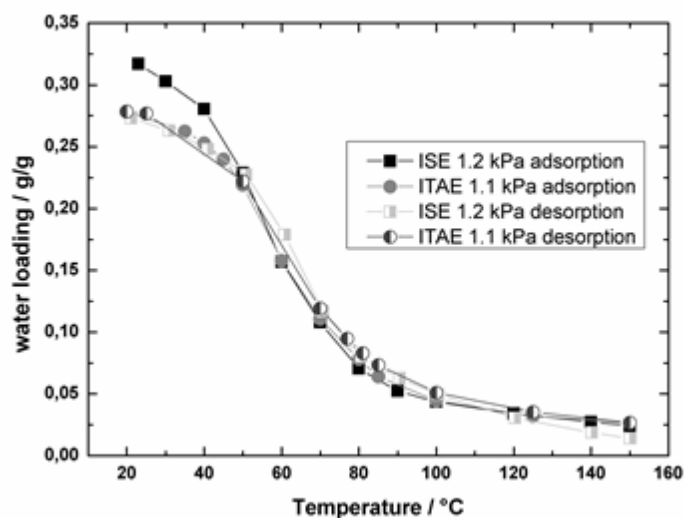

Fig. 3-15: Comparison of 1.1 kPa and 1.2 kPa adsorption/desorption isobars on a SAPO-34 sample. ISE measurements have been performed in an open flow system.

3.2.3.3 Influence of different measurement conditions

As written above, the proposed procedure is unfortunately not applicable for all measurement equipment. Especially using an open flow system, the drying of the sample by continuous evacuation is not possible.

Furthermore, the influence of the drying procedure is reduced, if the material can be desorbed at low temperatures, respectively the material is not too hydrophilic.

A first comparison between different equipment (balances) and different measurement procedures (isotherms vs. isobars) is shown in Fig. 3-16

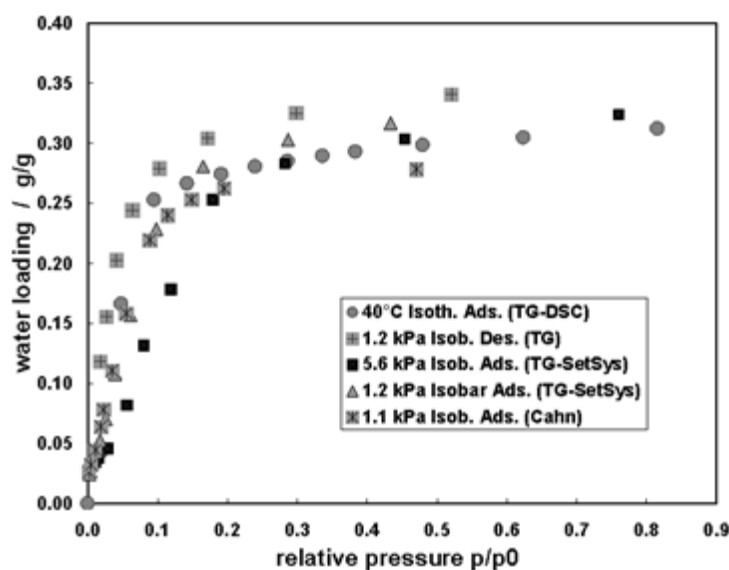

Fig. 3-16: Comparison of measurements for the SAPO-34 sample with different equipment and procedures.

The measurements have been performed with a Rubotherm thermobalance (TG), a Setaram SetSys Evolution (TG-SetSys), a Setaram simultaneous TG/DSC (TG-DSC) and a Cahn-balance model C2000 (Cahn). Details on the setup can be found in (Henninger, Munz et al. 2011), (Henninger, Schmidt et al. 2010), and (Restuccia, Freni et al. 1999).

In order to be able to compare isotherms and isobars even at different pressures, the water loading is shown versus the calculated relative pressure in case of the isobars, or the measured relative pressure in case of the isotherm.

At first view, there is a more or less broad scattering of the data points. Taking into account, that four different balances have been used, that the material shows a slight hysteresis between adsorption and desorption, and in addition that the stability of the materials is a critical issue, the agreement is surprisingly good.

3.2.4 Transformation

Several theoretical models and phenomenological laws have been applied to the adsorption data in order to provide an analytical expression describing the sorption

characteristics, i.e. the adsorption equilibrium, and to allow inter- and extrapolation of the measured data.

In case of the working pair water/silica gel there exist various models based on the Langmuir equation, like the modified Freundlich's equation used by (Saha, Koyama et al. 2003) or the related Toth equation used by Chua and co-workers (Chua, Ng et al. 2004). A different equilibrium equation, developed by Boelman is used in (Zhang, Liu et al. 2005). (Aristov, Tokarev et al. 2006) proposed a simple polynomial expression in which the equilibrium uptake is expressed as a function of the Dubinin–Polanyi adsorption potential. A phenomenological law derived from the Clausius–Clapeyron equation has been used by (Cacciola and Restuccia 1995).

3.2.4.1 Dubinin Transformation

In a first step, a transformation of the measured data according to Dubinin's theory of pore volume filling (Dubinin 1975) has been used for describing the physical properties of the adsorption characteristics regarding temperature T , pressure p and load x . Although this theory was originally developed for methanol/activated carbon it has been showed that it can be used for silica gel (Núñez, Henning et al. 1999), (Schicktanz and Núñez 2009).

In this work, only a brief description will be given. The first important quantity of this theory is the original named differential work of adsorption A , defined by

$$A = -\Delta G = RT \ln \left(\frac{p_s(T)}{p} \right) \quad 1)$$

where p is the equilibrium pressure, p_s the saturated vapour pressure and R the specific gas constant.

According to the Polanyi, Dubinin and co-workers adopted the thermodynamic interpretation of the Polanyi adsorption potential as the negative differential free energy of adsorption (ΔG), that is a variation in Gibb's free energy. The second characteristic quantity is the adsorption volume W defined as

$$W = \frac{X(T, p)}{\rho_{ads}(T)} \quad 2)$$

with X denoting the amount adsorbed at a given temperature and pressure and ρ_{ads} describing the temperature-dependent density of the adsorbate.

The theory states that all relevant thermodynamic properties can be derived from one equation

$$W = f(A) \quad 3)$$

expressed as the characteristic curve. Several different functional relation $W = f(A)$ have been proposed, whereof the Dubinin–Astakhov (D-A) and Dubinin–Radushkevitch (D-R) are the best known. A brief overview on extensions of the

classical D-A and D-R equations as well as a theoretical basis can be found in (Hutson and Yang 1997).

As can be seen in, the resulting characteristic curve for the working pair water/silica gel 127B according to Dubinin's approach is quite smooth, so the transformation seems to give reasonable results.

It has to be mentioned, that the fundamental condition of the temperature invariance of the characteristic curve for using Dubinin's approach cannot be guaranteed, as there are small discrepancies between different temperatures. However, in a first instance, the resulting curve and furthermore the analytical expression of the fit curve reflects the adsorption characteristic in a good manner. For the functional relation a classical D-A equation in reduced form

Fig. 3-17

$$W = W_0 \exp\left[-(bx)^n\right] \quad 4)$$

has been used.

Of course, the main advantage for using this approach is the fact, that the curve contains all thermodynamic information, compared to parameterization of isobars or isotherms.

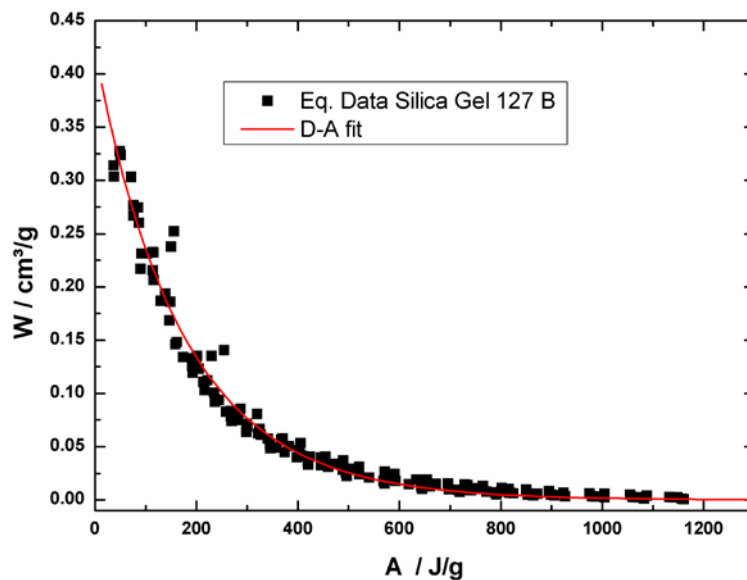

Fig. 3-17: Transformation according to D-A equation of the equilibrium points for water/Silica Gel.

3.2.4.1 Other Transformations

In case of the SAPO-34 the situation changes. As illustrated in Fig. 3-18, the transformation leads to a more scattered plot of data points. This is due to some hysteresis effects, which can be identified between the 1.2 kPa and 5.6 kPa adsorption measurement. In addition the shape of the characteristic curve is unfavourable for the D-A fit equation. Consequently the D-A fit leads to significant deviations. However, a similar transformation can be used, based on the following equilibrium relationship (Cacciola and Restuccia 1995).

$$\ln(p) = A(w) + B(w)/T \quad 5)$$

with the pressure p in mbar, temperature T in K and loading w as weight per cent. The parameters $A(w)$ and $B(w)$ are polynomial functions.

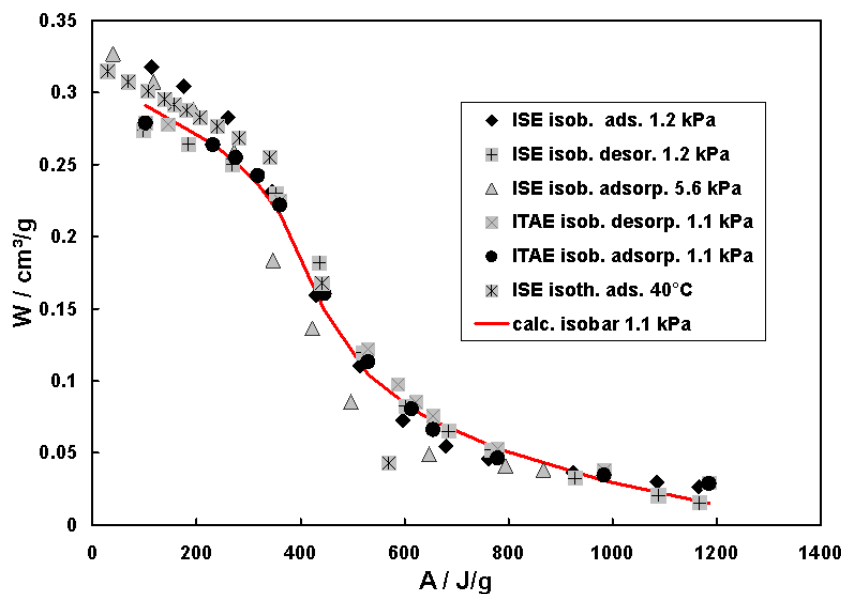

Fig. 3-18: Transformation of equilibrium point for water /SAPO-34 according to Dubinin's theory.

This expression is directly derived from classical Clausius-Clapeyron equation. The fundamental assumptions are a) the heat capacity of the adsorbate is equal to that of the liquid phase; b) the enthalpy of adsorption therefore is a function of the amount adsorbed; c) the enthalpy is independent of the temperature; d) the equilibrium conditions can be represented by a set of isostere.

Under these assumptions, the isostere on a diagram of $\ln(p)$ versus $1/T$ are straight lines. The slope is proportional to the enthalpy of adsorption.

It has to be mentioned, that this is only one possible thermodynamic expression for the adsorption characteristics. With regard to classical adsorption materials like zeolites a great variety of well-known models is available in literature and has been used for description of the adsorption of water like Langmuir, Sips, Toth and Dubinin-Astakhov.

3.2.5 Conclusions

As part of the work within the IEA annex 34 “Thermally driven heat pumps”, a standard measurement procedure for adsorption material properties has been proposed. First promising results with a good agreement between measurements performed at Fraunhofer ISE and at CNR-ITAE, using different techniques are shown. As first two candidates of a standard material to be used in a round robin test, a silica gel 127 B and a SAPO-34 have been chosen. Whereas measurement results for the silica gel according to the proposed procedure are in a very good agreement, comparison of the results for SAPO-34 is revealing some discrepancies. It has to be mentioned, that SAPO-34 is a quite interesting but difficult material to be used, as the adsorption characteristic shows a steep adsorption in a very narrow relative pressure range. Therefore, small deviations in temperature or pressure lead to a large error.

In addition a proper thermodynamic description of the adsorption characteristics is possible by the now available data which is especially important with regard to the material database established within this Annex. It is shown that for the silica gel 127B the Dubinin-Astakhov approach shows very good results. For the SAPO 34, the Dubinin approach is not really applicable; however a different approach with quite good agreement is shown.

In summary, out of the work on a common measurement procedure within Annex 34 we reached our goal to stimulate the discussion about measurement procedures of sorption materials as well as invite to participate and use this procedure to create a public knowledge about available sorption material properties on a comparable base.

3.3 New developments on adsorption materials and material database

Beside the need for a common measurement procedure and the work started within Annex 34, several new developments on adsorption materials were reported in literature. As the aim of Annex 34, especially of Task C was to create a public knowledge or even a material database, novel developments were tracked and a brief summary is given in the following section.

As most of the available adsorbents have originally been developed for different applications there is a large optimization potential. Therefore the discovery of new microporous materials for the use in adsorption heat pump processes is still a fundamental research topic with exciting improvements and numerous publications. (Aristov, Restuccia et al. 2002), (Jänchen, Ackermann et al. 2004), (Ng and Mintova 2008), (Henninger, Schmidt et al. 2010).

With regard to the well-known zeolites, the main focus was on optimization and adjustment to the given boundary conditions through the use of different cations and/or lower alumina content. In (Henninger, Schmidt et al. 2010) samples of the faujasite framework type with different cations have been evaluated. Amongst different possible cations, the lithium and especially the rare-earth LaNa exchanged form has been selected as the most promising one for the use in heat transformation applications based on water adsorption.

In addition novel sorption materials with higher surface area, larger pore volume and higher working fluid uptake have been developed and reported in the last years.

Closely related to the zeolites new materials like the aluminophosphates (AIPOs) and the silica-aluminophosphates (SAPOs) have been successfully adapted to the use in adsorption heat pumps or chillers (van Heyden, Munz et al. 2009), (Ristić, Henninger et al. 2010).

The newly developed materials like SAPO-34 and AIPO-18 show up to six times higher working fluid exchange compared to the silica gel reference. With regard to new adsorber concepts, based on these materials or composites and faster cycling times an intense investigation of the stability under application conditions, which is continuous cycling between high and low temperatures under pure adsorptive atmosphere is needed. Especially with regard to market entrance of these systems intensive investigations on hydrothermal stability are mandatory (Henninger and Munz 2009), (Henninger, Munz et al. 2011), (Henninger, Munz et al. 2011), (Munz, Henninger et al. 2011).

Beside the inorganic materials like zeolites and aluminophosphates a new class of microporous materials known as Porous Coordination Polymers (PCPs) or Metal-Organic Frameworks (MOFs) has emerged.

With regard to water adsorption capacity, porous coordination polymers (PCPs) are the most promising materials identified so far (Henninger, Habib et al. 2009), (Ehrenmann, Henninger et al. 2011).

Like zeolites and aluminophosphates, metal organic frameworks are crystalline open porous materials with a one, two or three-dimensional framework. In contrast to the zeolites MOFs are not purely inorganic but inorganic-organic hybrid materials based on metal atoms or metal clusters as nodes, which are linked by organic ligands. Compared to traditional adsorbents used in heat pump applications, MOFs exhibit a much richer variety in composition, pore structure and topology. The cluster/linker concept allows the tunability of pore structures and chemical functionality over a wide range (Henninger, Jeremias et al. 2011).

Within Annex 34 a database for adsorption materials has been developed and several materials were included. It is announced that the work will be continued within Task 24/Annex 42 and that the later version of the material database will be public. So far, 9 different materials are included.

3.4 New developments in absorption technology

3.4.1 Ionic liquids as new working pairs

Up to the 1980s many different working pairs for absorption chillers have been proposed. Later, only few research groups investigated new absorption working pairs. This is because the prevalent working pairs water/LiBr and ammonia/water meet the existing requirements of common applications quite well. Water/LiBr is used for air-conditioning and NH₃/water mainly for refrigeration.

Nowadays, applications with further requirements have been discussed as there are high medium temperature level (solar cooling in hot climate, heat pump use in retrofit applications) and high driving temperature level (high efficient triple-effect chillers, heat transformers for industrial applications). This required a reanimation of research activities regarding new working pairs to overcome the drawbacks of the prevalent

working pairs. LiBr solution runs the risk of crystallization at high temperature lift and the corrosion problem becomes grave at driving temperatures above 160°C. The drawback of ammonia/water systems is the remarkably increasing pressure with higher medium temperature level which is problematic on the one hand regarding construction issues and on the other regarding pump energy consumption.

In the last few years, ionic liquids - organic salts composed entirely of ions which remain liquid at or close to ambient temperature - have been discussed as absorbents capable to replace LiBr solution as they do not have the crystallization risk and they are assessed to be less corrosive.

3.4.1.1 Research at TU Berlin

In 2008, the Technical University of Berlin and the company Evonik Industries AG started a government-funded project (German Federal Ministry of Economics and Technology by grant no. 0327472A and B) to evaluate the potential of ionic liquids as new absorbents for absorption chillers (Kühn 2009), (Schneider, Schneider et al. 2011). In the course of the project Evonik produced several customized ionic liquids which have been tested in a small scale absorption chiller prototype with glass shell at the TU Berlin (see Fig. 3-19).

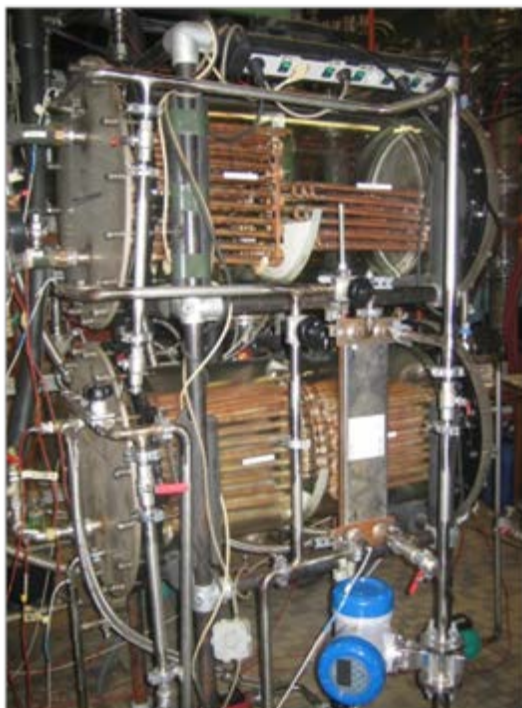

Fig. 3-19: Photograph of the test rig at TU Berlin

The best tested ILs showed the same efficiency (COP) as the water/LiBr system and a cooling capacity (Q_E) representing 80% of the cooling capacity of a water/LiBr system without additives (65% of a water/LiBr system with 2-ethyl-1-hexanol additive, see Fig. 3-20). The tests presented in Fig. 3-20 have been carried out with 75°C driving temperature, 27°C cooling water temperature and 18°C chilled water inlet temperature. Due to the higher viscosity of the ILs a more powerful solution pump has been installed after testing IL3 to achieve a solution flow rate (V_{Sd}) of 100 l/h or more for ILs, too. The test of IL7 has been carried out after the installation of a new condenser (C) and a new generator (G) heat exchanger with slightly other

dimensions. Therefore, this test results must be compared to the appropriate LiBr test results (previous column). The analysis of different influencing parameters indicated that the reduced cooling capacity results from a mass transfer inhibition probably due the higher average solution concentration during operation and/or the molecular sizes of the ionic liquids.

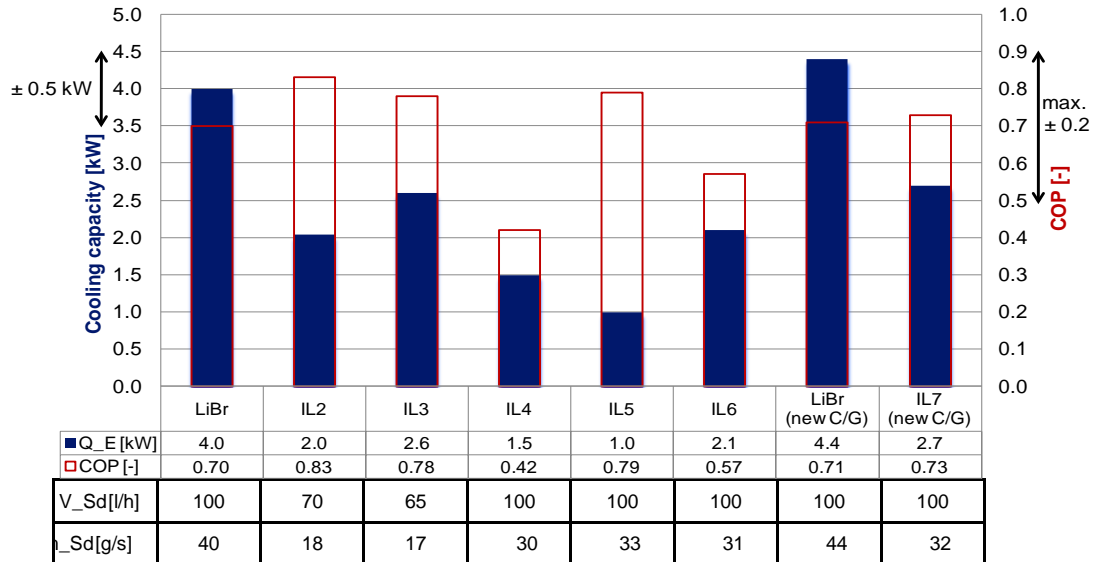

Fig. 3-20: Test results of water/LiBr and water/IL working pairs

Nevertheless, the potential of ionic liquids as absorbents for absorption chillers has been shown. It has been experimentally demonstrated that the tested ionic liquids allow a depression of the water partial pressure in the same order of magnitude as LiBr solution, but in most cases at higher salt concentrations. It has also been demonstrated that they do not crystallize at temperatures above 20°C and that a stable operation over a wide range of driving, cooling and chilled water temperatures is possible. The use of ionic liquids in absorption chillers appears to be possible under conditions at which LiBr solution runs the risk of crystallization. Cooling water temperatures up to 60°C have been tested without crystallization of the IL. Additionally, a strategy for the determination of the best additive mix has been developed and potential advantages by using adiabatic absorption have been studied. First experiments using a spray dispersion test rig have been carried out. The possibility to tailor the properties according to the requirements described is intriguing. More tests are required, but a competitive IL-based working pair seems to be possible in the near future.

3.4.1.2 Research at ZAE Bayern

To investigate the suitability of ionic liquids - especially 1-ethyl-3-methylimidazolium ethyl sulphate – as sorbent at the ZAE Bayern an experimental absorption chiller was built. Due to the expected properties of ionic liquids, particularly high viscosity and surface tension, generator and absorber of the system were built as spray chambers with external plate heat exchangers (see Fig. 3-21). This optimizes the heat and mass transfer, since both processes are separated and the wetting of a tube bundle heat exchanger is not further required.



Fig. 3-21: Photograph of the test rig at ZAE Bayern

The measurements show the general feasibility. Thermally driven chillers can run and supply chilling capacity with an ionic liquid as sorbent. While operated with EMIM EtSO₄ the experimental plant reached a lower specific capacity per volume compared to commercial systems based on H₂O/LiBr and using tube bundle heat exchangers (Radspieler and Schweigler 2011). Further research under realistic operation conditions (primarily determined by the circulating mass flows of the sorbent) has to be done. In addition, further efforts are needed to find a suitable combination of working fluid and applied process.

3.4.1.3 Research at TU Graz

A single-stage AHP-process with working mixtures of ammonia as the refrigerant and ionic liquids (ILs) as the absorbent were investigated at TU Graz by means of thermodynamic simulations using the software program ASPEN Plus (Kotenko, Moser et al. 2011). From the literature the following binary mixtures of NH₃/ILs were found: NH₃/[bmim][BF₄], NH₃/[bmim][PF₆], NH₃/[emim][EtSO₄] and NH₃/[emim][TF₂N].

Thermodynamic simulations of the investigated NH₃/IL AHP-processes have shown that their efficiencies at certain boundary conditions are higher than those of a conventional NH₃/H₂O AHP. However, the COP of the investigated NH₃/IL AHP-processes decreases more in comparison with a conventional NH₃/H₂O AHP when the temperature lift increases. The reason for that is a low difference between the NH₃ mass concentration in the rich and poor solution and therefore a high solution flow rate.

The “best” simulation results have been obtained for the AHP-process using the working mixture NH₃/[bmim][PF₆] (see Fig. 3-22). It is more efficient than a

conventional NH_3 / H_2O AHP at $t_{ABS} / t_{EVA} = 25/5^\circ C$ and $35/5^\circ C$ if t_{GEN} is higher than ca. $75^\circ C$ and ca. $115^\circ C$ respectively.

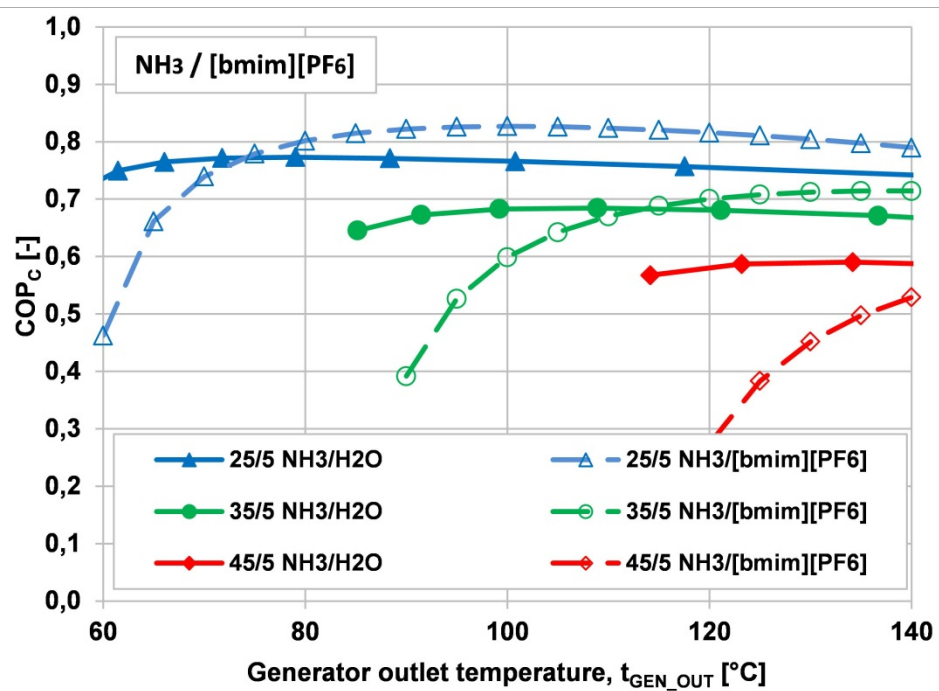

Fig. 3-22: Simulation results of the COP for $t_{ABS}/t_{EVA}=25/5^\circ C$, $35/5^\circ C$ and $45/5^\circ C$ of $NH_3/[bmim][PF_6]$ AHP-processes without rectification column in comparison to a conventional NH_3/H_2O AHP-process with rectification column depending on the generator outlet temperature

In general, it was concluded that following are consequences caused by ILs instead of H_2O with NH_3 as refrigerant:

- the rectification column is not necessary;
- the ratio of the required solution pump power demand to the generator heating capacity increases significantly;
- the required capacity of the solution heat exchanger increases as well and has stronger influence on the process COP.

As the next step in the research of NH_3 / IL AHP-processes experimental investigations are necessary.

More information can be found e.g. at (Moser and Rieberer 2011)

3.4.2 High Temperature Regenerator

If fossil energy is used as driving power for a TDHP, the machine should be a multi effect machine, to get a higher COP. This is possible as burning fuel can achieve basically every temperature. Therefore, a new regenerator was developed that improves the heat transfer from hot flue gas to LiBr solution. This generator could also be used for exhausted gas from CHP e.g. The main improvement is the boiling process in the solution which allows natural convection in the tubes. (Bauer, Plura et al. 2008)

3.4.3 Inert gas analysis in absorption TDHPs

Highly efficient ammonia/water absorption heat pumping (AHP) processes (e.g. the GAX-process) require a high desorption temperature level of e.g. 200°C and above. At these conditions the formation of non-condensable gases can take place, which can be dedicated to two chemical processes: corrosion of steel and thermal decomposition of ammonia.

In order to identify the responsible chemical process tests with an absorption / desorption test rig as well as corrosion tests using autoclaves have been performed at TU Graz (Austria).

In Fig. 3-23 a schematic drawing of the test rig is shown. The generator - which consists of a co-axial tube-in-tube heat exchanger - is heated by a secondary water loop, which itself is electrically heated. Both circuits, the secondary water loop and the ammonia water solution, are circulated by means of a thermosiphon, where the electrically heated water circuit and the generator work as a bubble pump. This approach allows to easily control and measure the temperature level of the driving heat for the generator and at the same time avoids local over-heating (which likely occurs in an electrically heated generator). The partly evaporated ammonia/water solution rises up and flows into an air-cooled condenser/absorber section. This includes a vessel where test probes can be inserted. The vapour-phase coming from the generator is then absorbed by the solution and is fed back to the generator, completing the working cycle. At the top of the condenser there is a connector through which the gas sample for the analysis can be extracted.

The produced non-condensable gas has been analyzed using gas-phase chromatography. The results show a large initial corrosion rate which decreases with time. At all tests the carbon steel autoclaves has shown significantly lower corrosion rates compared to the stainless steel components. Regarding the thermal decomposition no dissociation products has been detected up to a temperature level of 290°C.

Further information about the Austrian project can be found in e.g. (Moser, Zotter et al. 2011).

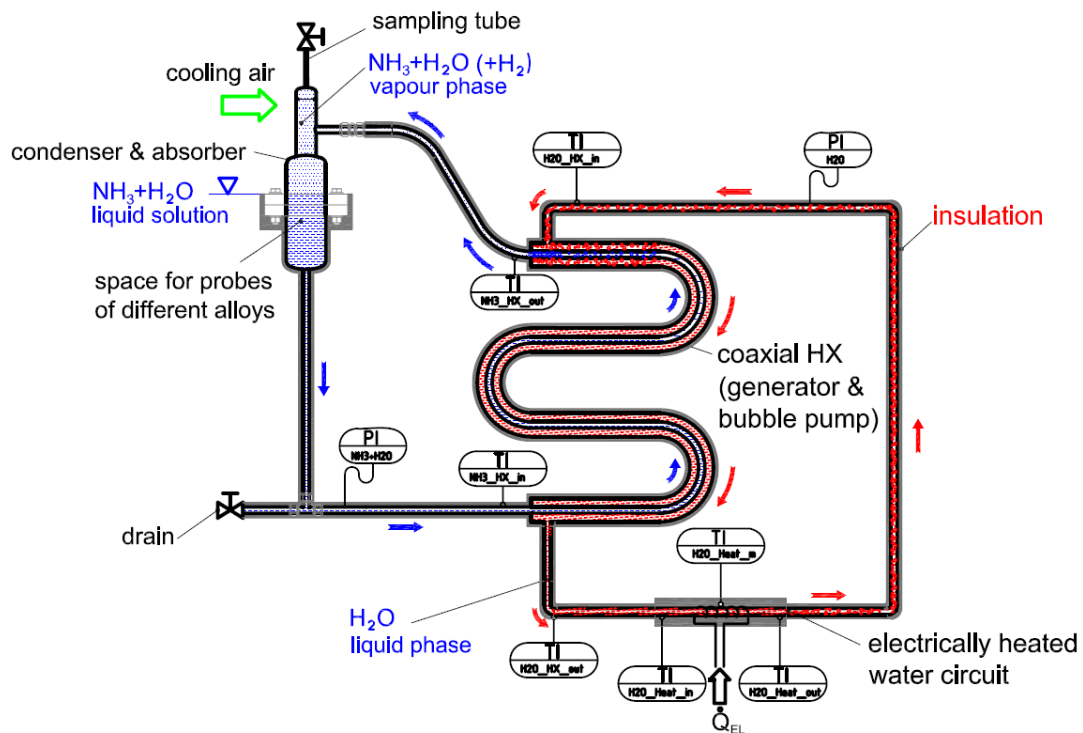

Fig. 3-23: Schematic drawing of the thermosiphon cycle test rig with indicated instrumentation

3.4.4 Optimized dimensioning of heat exchanger surfaces

Absorption chillers can be seen as a system of interdependent heat exchangers, interacting by concentration and temperature of working fluids and by pressure level. On the one hand the dimensioning of the heat exchanger surfaces of the different components should ensure that the capacities, temperature levels and temperature spreads in the external circuits comply with the requirements. On the other hand the heat exchangers hold a large share of the costs and should be minimized. The optimal solution for the distribution of heat exchanger surface on the single heat exchangers depends on the temperature differences between external and internal fluids, heat transfer coefficients, cost factors, etc...

One way to find an optimized solution is a detailed simulation of the circle, using a material database for the working fluids and an equation system, mainly consisting of the energy, mass and salt balances of the components. To reduce the complexity, analytical solutions for the optimization process were developed. Starting from the characteristic equation, a group of equations giving the optimized distribution of heat exchanger surface to the single components is derived. They can be used for conventional single-effect absorption chillers as well as for innovative double-effect and double-effect/single effect cycles (Wuschig, Plura et al. 2008). In general these methods are not only suitable for absorption but also for adsorption cycles.

4 SYSTEM TECHNOLOGY

Task D deals with the system technology and is intended to give an appraisal on the different ways of integrating the TDHP in a system of heat sources and sinks (integration of heat rejection, air/ground- heat sources, efficient burners) and different control strategies.

The state-of-the-art of the technology showed during the demonstration of the work are not yet available on the market, due to dissimilar solutions adopted by the manufacturers.

At the same time, it became clear that the description of working principles and the performance assessment was unclear for most of the cases we worked on. For this reason, the objective of the subtask drifted towards the definition of a common procedure for systems representation.

In the following chapter, suggestions are given on possible methods to standardize the systems' representation, the hydronic connections and the names of energy flows as used in Chapter 2.

4.1 Introduction

The methods used for plants representation shall take into account that the analyzed systems have:

- Common components
- A choice of layouts and sizes
- Different control strategies
- Varied boundary conditions

Based on these assumptions, we found systematic ways for suitable graphical representation of the different layouts and energy fluxes involved. These illustrations help one to understand easily how the system is built; while clearly taking into account the energy fluxes (both thermal and electric) established among the components at different operational conditions. Performance figures are finally computed starting from the energy fluxes identified.

The different approaches reported in the following chapter disclose the pros and cons to better highlight the hydronic connections among the components, and to better **emphasize** energy flows through the system. We have not yet assessed a practical and comprehensive way to tackle both hydronic and energy fluxes.

4.2 Max System representation

During the former IEA-SHC Task 38, researchers elaborated on a novel method (see Fig. 4-1) of solar cooling systems representation.

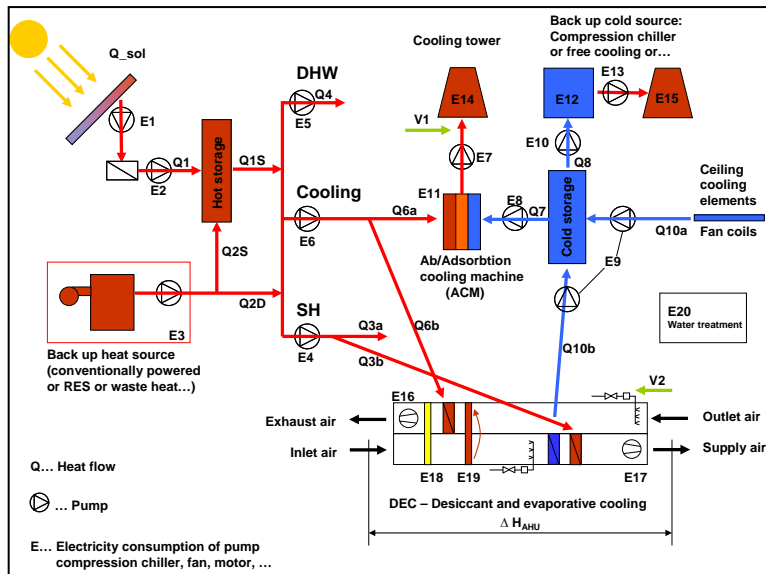

Fig. 4-1: Max-system representation from IEA-SHC Task 38

This allows an easy statement of the system hydronic, by simply deleting components (and connections) that are not used in the specific case. The thermal fluxes are represented by the connections among the components, while electricity consumptions are associated to any components (pumps, heat rejections and heat pump).

The main issue with this representation method is that it does not tackle possible combination of component and system configurations. While it was well suited for most of the systems investigated in IEA-SHC Task 38, nevertheless, it does not take into consideration a range of possibilities such as:

- Direct fired thermally driven heat pumps
- Different operating modes of the heat pumps (main and backups)
- Simultaneous heating and cooling loads (i.e. in commercial buildings applications).

If the max system representation aims to tackle also those complex applications, it results in quite an intricate generic scheme reported in Fig. 4-2 . Fig. 4-3 shows a practical example of a simultaneous heating and cooling application.

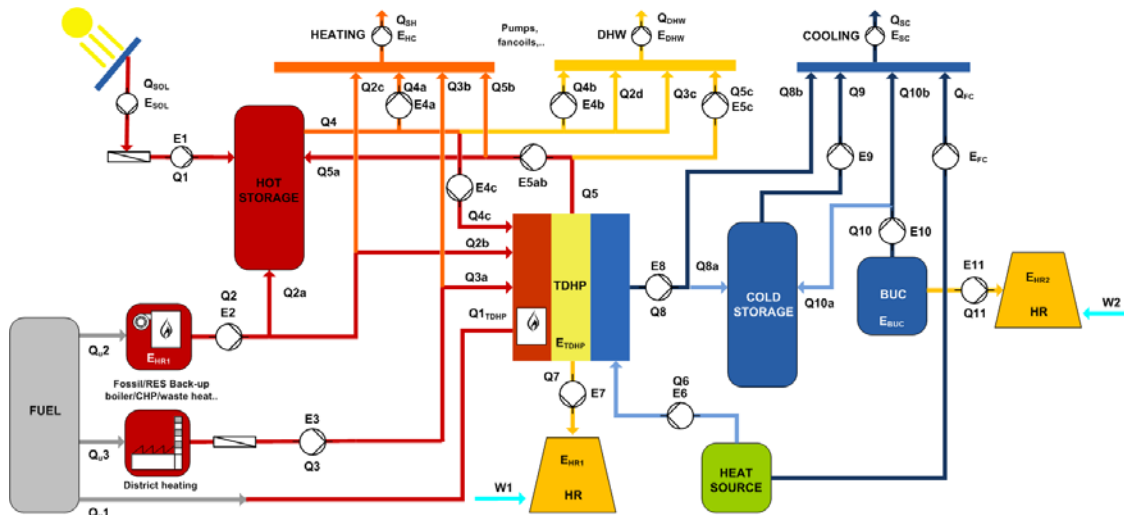

Fig. 4-2: Max system representation for a heating and cooling, direct and/or indirect fired application

As you can easily notice, the hydronic scheme becomes more and more complicated.

- Connections (energy fluxes) among components are not handled easily
- Nomenclature is not intuitive anymore
- Placement of any possible circulation pump is challenging
- Definition of the energy fluxes used for the calculation of the system/subsystems performance is difficult.

For these reasons, the use of two additional system representation methods was explored, again in collaboration with IEA-SHC Task 38 and IEA-SHC Task44/HPP Annex 38.

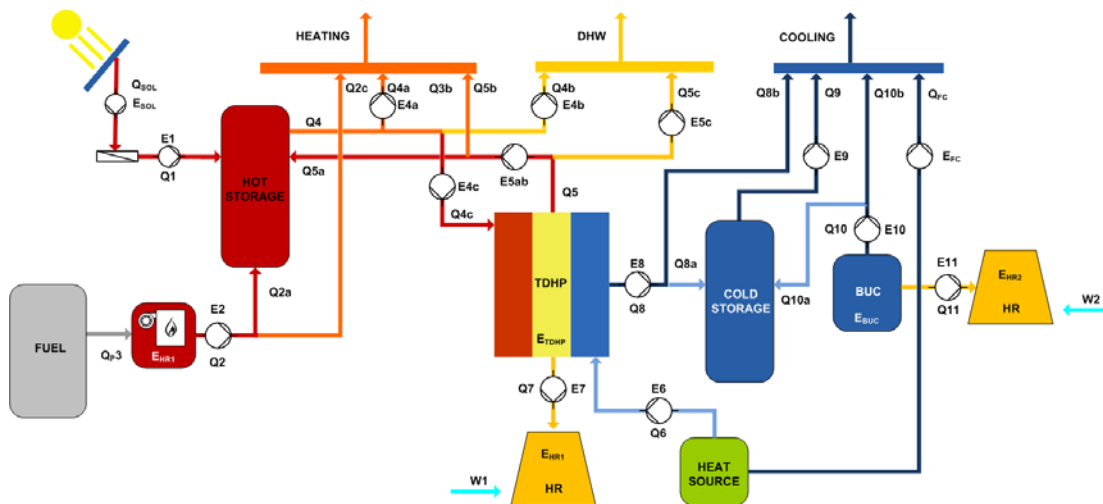

Fig. 4-3: Example of indirect fired heating and cooling application

4.3 Schematic Hydronic Representation

Another possibility to represent the different TDHP systems in a graphical way is the so-called generic system. This method is based on a scheme defined for solar cooling systems within IEA task 38 of the SHC Programme (Solar air-conditioning and refrigeration). It represents the system topology and the hydronic structure of sorption

heat pump systems and covers both sorption heat pumps systems serving for the provision of heating and of cooling.

The method will be described in the following section, and the description can also be found in (Becker 2009). The description was slightly adjusted for this report.

The generic sorption heat pump systems are composed of classic components and represent distinct system topologies applicable for various operating conditions and system boundaries. This information is not product-specific, nor does it refer to a specific brand. The main aspect of the study is the hydronic structure of the systems. In addition, application aspects of the system components are discussed.

4.3.1 Basic system topology

The core component of the sorption heat pump system is the application of the thermally driven heat pump either for heating or cooling. In either case, the sorption heat pump operates at three temperature levels.

- Driving heat is supplied at highest temperature both in heating and cooling operation.
- Useful cooling is provided by heat uptake of the evaporator at lowest temperature with rejection of waste heat to ambient at an intermediate temperature level.
- With heating operation the heat output at intermediate temperature is the useful effect, while ambient heat is supplied to the evaporator of the heat pump at lowest temperature level.

In some cases simultaneous use of the cooling at low temperature levels and heat output at intermediate temperature is accomplished. This yields to maximised use of driving heat input. For simplicity, in the following sections the function of chilling and heating are discussed separately. Simultaneous operation of cooling and heating can be understood by overlaying the respective system functions. The first example is of a solar cooling system showing the structure of the generic system. More examples can be found in the reports about the demonstration plants in the appendix.

Three heat carrier loops are connected to the sorption cycle at three different temperature levels. The heat generated by the solar thermal system serves as driving force for the thermally driven chiller. Taking into account the supply of useful cooling and the transfer of the chillers reject heat to the ambient, a system with three sub-systems is formed, as shown in Fig. 4-4:

- The solar thermal system provides heat to the desorber G of the chiller.
- Rejected heat of condenser (C) and absorber or adsorber (A) are released via cooling water loop and cooling tower.
- Useful cooling is provided by the evaporator (E) and supplied to the consumer via the chilled water loop.

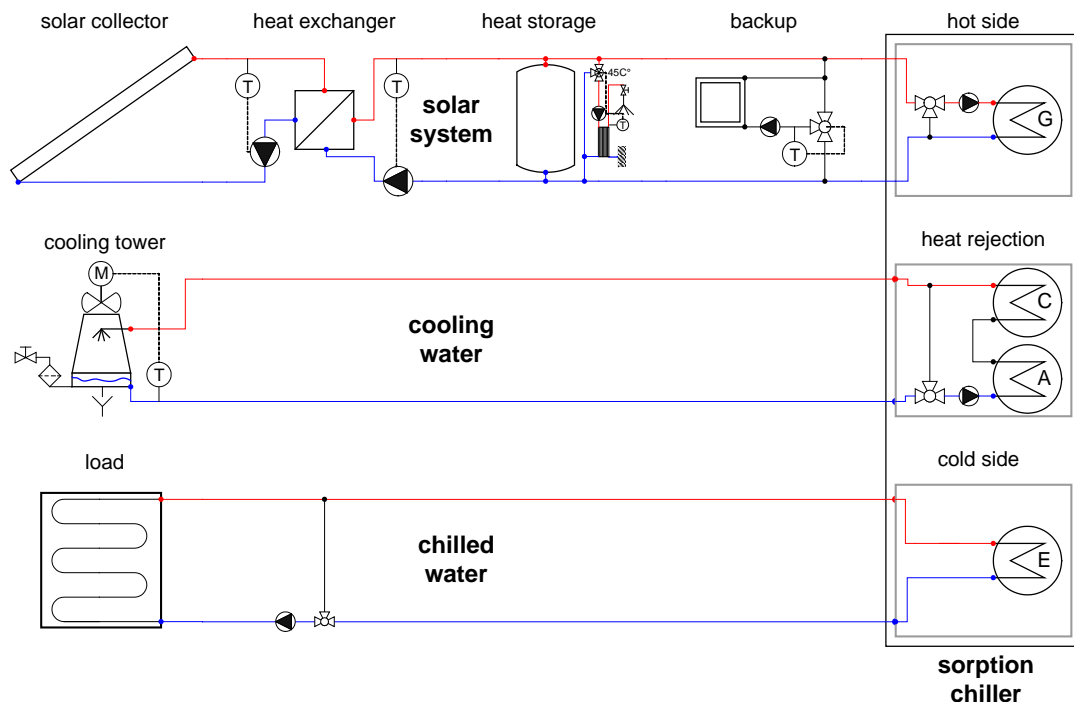

Fig. 4-4: Basic solar cooling system: Thermally driven chiller coupled to solar thermal system, cooling water loop, and chilled water loop.

4.3.2 Composition of generic systems

TDHPs for heating of cooling applications operating under different ambient conditions and specific heating and cooling demand characteristics. A variety of technical options is available for all three sub-systems: e.g. different room-side appliances for heating and cooling, heat or cold storages, different hydronic concepts, etc.

The different options are presented on the basis of a standardized system topology according to the basic structure of the “generic system” with sub-systems operating at different temperature levels. For each sub-system a structural template has been defined containing placeholders for the integration of additional components (see Fig. 4-5).

In detail, the following options are to be specified for the three sub-systems.

Driving heat:

- Driving heat source: Solar collector, District heat, Direct firing
- Heat exchanger
- Heat storage
- Backup-heater

Heat output at intermediate temperature level:

- Chiller: Main cooler, Auxiliary cooler
- Heat Pump: Space heating appliances

- Heat exchangers for separation of primary and secondary cooling loop

Low temperature sub-system:

- Chiller: Room-side cooling appliance
- Heat Pump: Type of ambient heat source
- Distribution of chilled water to the cooling appliances
- Cold (chilled water) storage
- Backup chiller

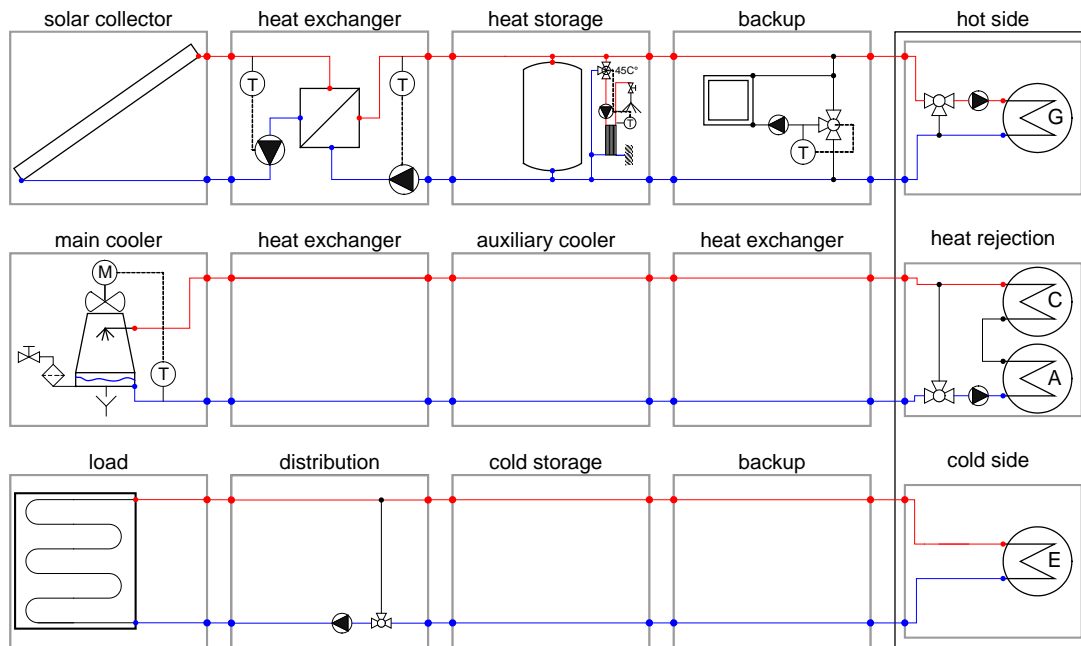

Fig. 4-5: Generic system: standardized system topology with placeholders for the integration of optional system components.

In the following sections, typical constellations and alternative components for the three sub-cycles are presented. For each placeholder all relevant options together with a characterisation of technical and operational aspects are provided.

4.3.3 Driving heat input at highest temperature level

The sorption cycle can either be driven by direct-firing using a fossil fuel, i.e. natural gas or oil, or by any other heating agent, such as steam or hot water from various sources (Fig. 4-6). Thus heat from solar thermal systems can be used as renewable energy sources, as well as heat from co-generation plants distributed via district heating networks or industrial waste heat.

Indirect Fired

Direct Fired

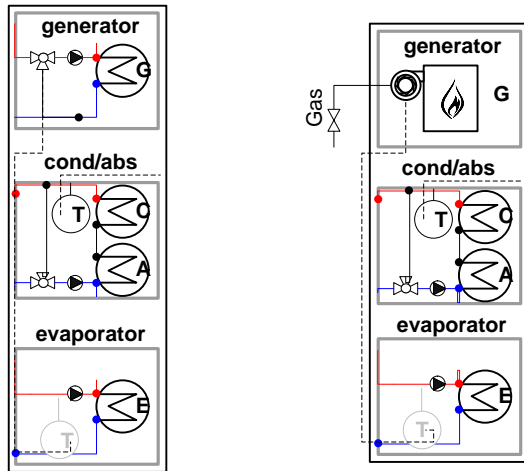

Fig. 4-6: Indirect (left) and direct fired (right) sorption heat pump.

With regard to solar thermal systems, all types of **solar collectors** – i.e. flat plate collectors, vacuum tube collectors and concentrating collectors – are applicable. Vacuum tubes and concentrating collectors often exhibit higher collector efficiencies at elevated temperatures of the solar loop. Thus higher availability of the system is accomplished during times of limited solar irradiation (Fig. 4-7).

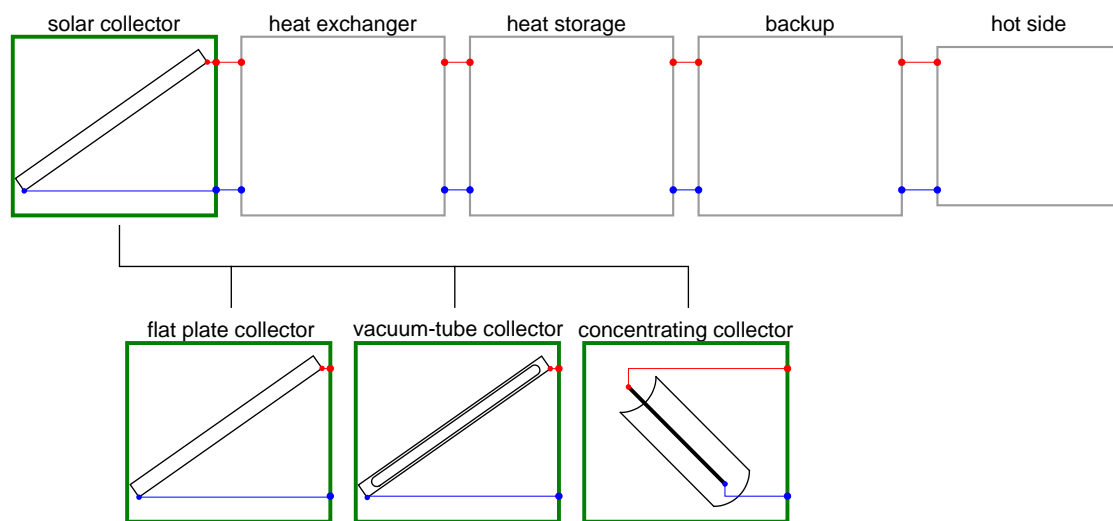

Fig. 4-7: Solar sub-system: options for the solar collector

In the solar thermal system a **heat exchanger** (see Fig. 4-8) can be integrated for separation of primary and secondary loop. In conventional systems a water/glycol mixture together with a separating heat exchanger is used, assuring trouble-free operation throughout the year at the expense of a reduction of the temperature level in the secondary loop due to the heat transfer in the heat exchanger. In order to avoid the reduction of the temperature level a “direct” utilization of the solar heat may be applied. In this case either freezing of the heat carrier water has to be avoided by means of heat input from the backup-heater or an electrical heater, or a drain-back concept has to be chosen. When the latter is applied, the collector loop is filled by the circulating pump only when substantial solar contribution for operation of the system

in heating or cooling mode is to be expected. A third option would be to drive the chiller directly with the water-glycol mixture, taking into account changing heat transfer rates in the desorber of the chiller.

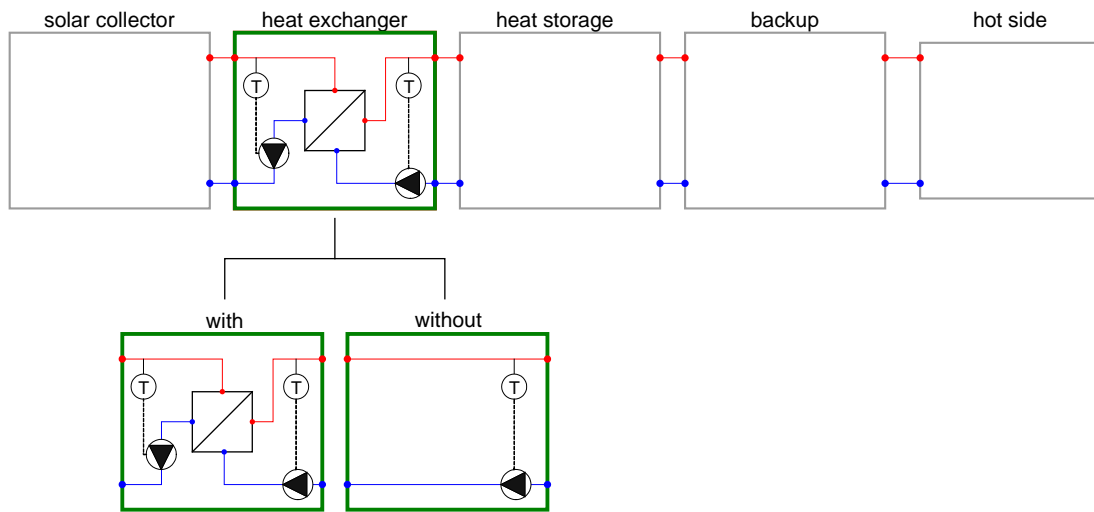

Fig. 4-8: Solar sub-system: heat exchanger for separation of primary and secondary solar loop.

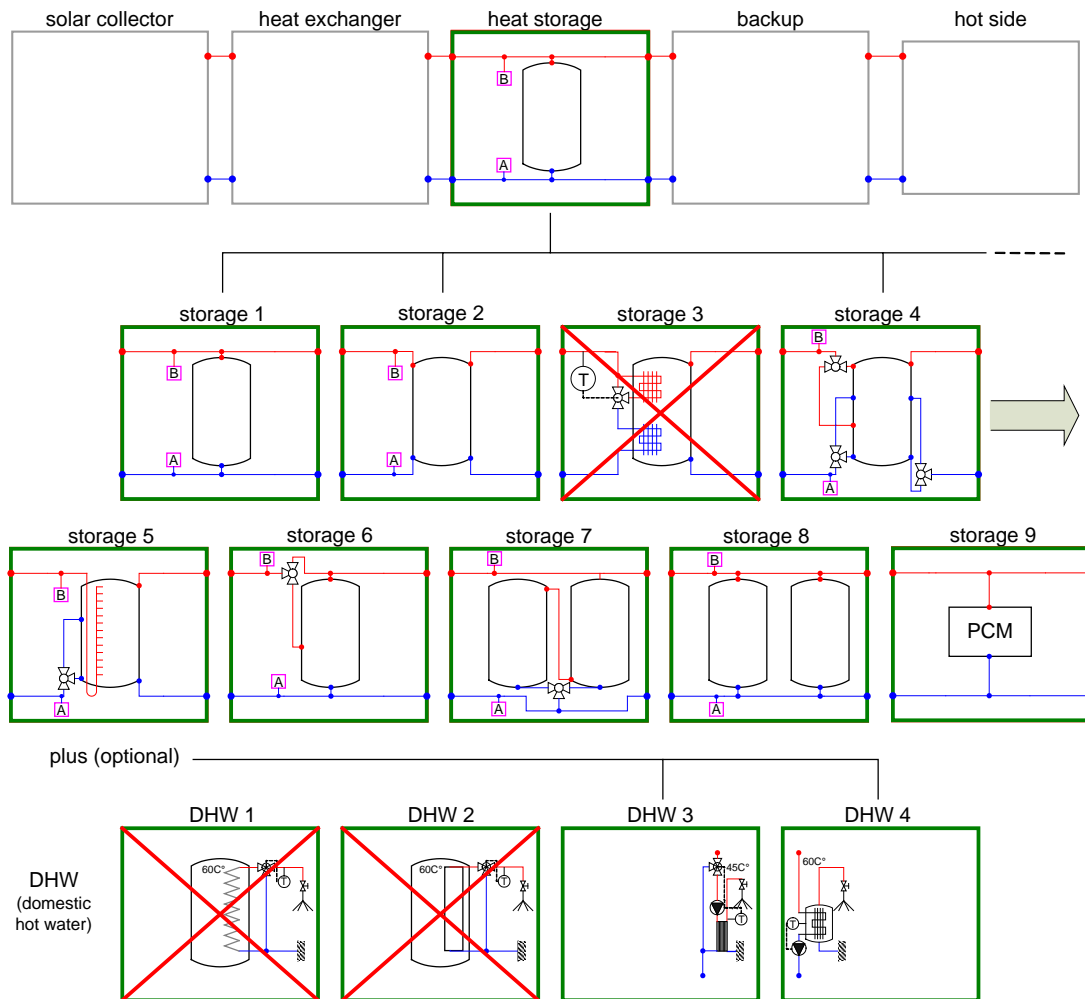

Fig. 4-9: Solar sub-system: options for the heat storage and domestic hot water preparation.

In order to balance solar gain and the profile of the heat consumption, solar thermal systems comprise hot **water heat storage**. For operation of the thermally driven chiller solar heat at a sufficiently high temperature level is required and any devaluation (cooling by mixing or heat exchange) of the solar heat should be avoided. Thus a direct integration of the storage without heat exchanger is favourable, eliminating a temperature drop during charging and discharging of the store. Therefore, option “storage 3” in Fig. 4-9 is not suitable for solar cooling. In addition the active storage volume should be variable in order to achieve a quick increase of the solar loop temperature for minimum delay between onset of solar irradiation and start of the production of chilled water by the chiller. For this purpose a direct link between solar heat generation and supply of driving heat to the chiller can be chosen (“storage 1, 6, 7, and 8”). For these cases it must be assured that the store still properly serves as a hydronic switch between heat generation and load. Therefore only minimum pressure drop between supply and return line of the solar thermal system across the store is allowed in order to avoid parasitic flows. Parasitic flows might occur when only the solar collector is charging the store (parasitic flow may occur at the auxiliary heater or the desorber) or when the store is only discharged (parasitic flow may occur on the collector side). In addition, the return line feeding cold water from the storage to the collector inlet can be switched to a lower outlet port of the store when the top layer of the storage has reached the desired driving temperature for the operation of the chiller (“storage 4 and 5”). By that means a reduced thermal inertia of the solar cooling system is achieved with shorter start-up time in the morning. In larger systems two storage tanks connected in series to the solar heat supply can be used (“storage 7”). In this configuration charging of the second store is started only when the first store has been heated completely. “Storage 8” with two parallel storage tanks may serve for reduced flow speed in the storage facilitating a stratified loading with optimum temperature in the top layer of the storage. For the same purpose storage tanks with a distributed feeding system for stratified charging can be applied (“storage 5”). Latent heat stores (“storage 9”) offer the advantage of high thermal capacity in a limited temperature interval. Accordingly, a substantial reduction of the thermal inertia of the system could be achieved; yet these systems are still under development.

Apart from space heating and the supply of driving heat for the sorption chiller, solar heat serves for the generation of domestic hot water. In solar combisystems without cooling function, tap water is either heated inside the main heat store by means of an integrated heat exchanger (“DHW 1”) or a tank-in-tank system (“DHW 2”) or an external flat plate heat exchanger (“DHW 3”) or a separate domestic hot water tank (“DHW 4”) is used. For the first two options with tap water preparation inside the main heat store, most manufacturers recommend to limit the tank temperature to about 60°C in order to avoid scaling and calcification in the tap water system. This limitation is not compatible with the requirements for the operation of the thermally driven chiller which is operated with about 60 to 90°C hot water supply temperature. Consequently, a solution with external DHW preparation (“DHW 3” or “DHW 4”) is more favourable.

Alternatively to the use of solar thermal heat, various other heat sources may be applied to drive the chiller or heat pump. In case of solar cooling this heat input serves for backup operation when the solar gain is insufficient. In district cooling applications or heat pump systems this heat input is the main driving force for the heat

transformation system. In Fig. 4-10 the supply of driving heat by district heating installations or co-generation systems is displayed.

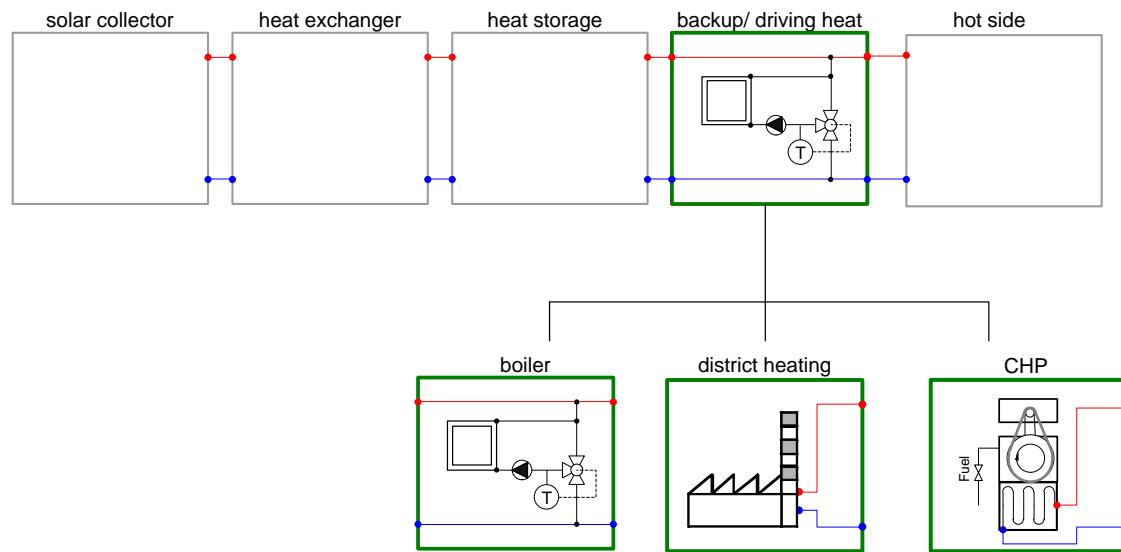

Fig. 4-10: Driving heat sources: Boiler, District heating, and Heat from co-generation systems.

For the integration of the driving heat source different hydronic constellations, i.e. parallel or serial, are available (see Fig. 4-11).

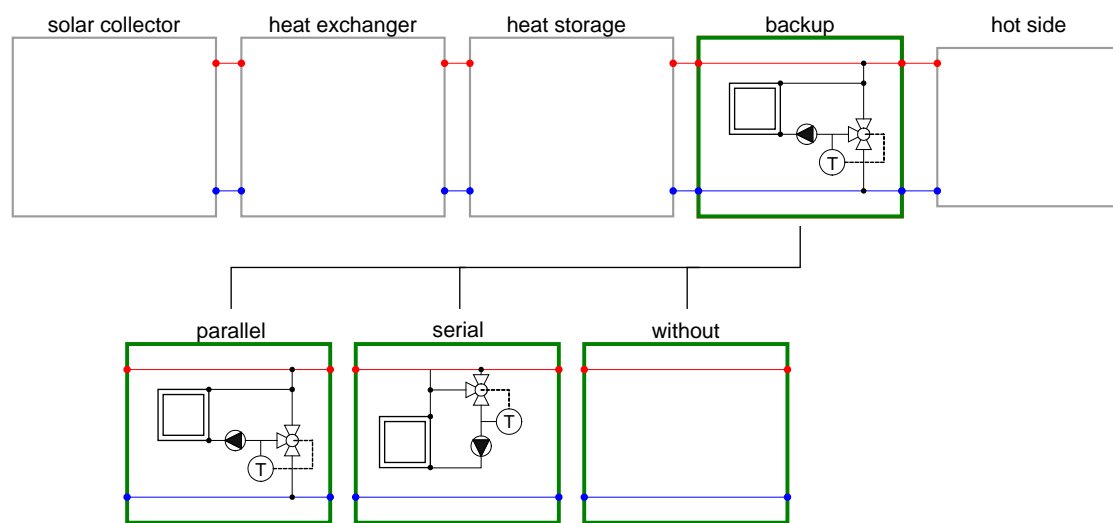

Fig. 4-11: Solar sub-system: options for the integration of the backup-heater.

4.3.4 Heat output at intermediate temperature level: Heat rejection (waste heat) or useful heat output for space heating or other heat utilization

In cooling systems the chiller serves for the provision of chilled water. Both entering heat flows, i.e. driving heat input at the desorber at highest temperature level and heat extracted from the building, have to be rejected to ambient at intermediate temperature.

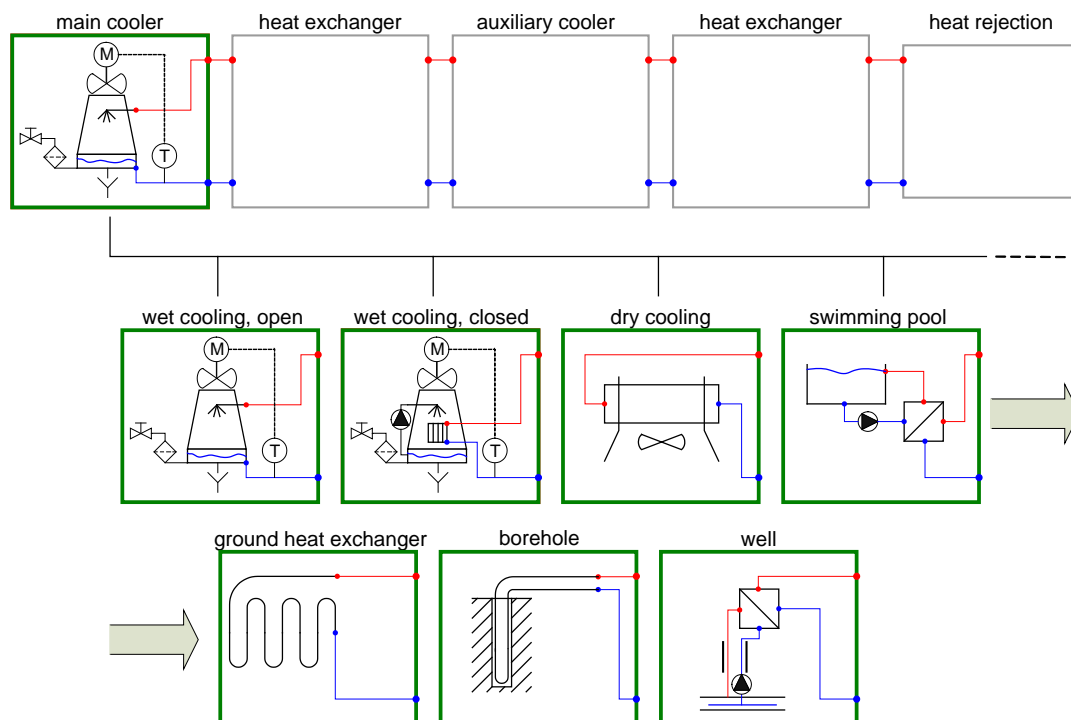

Fig. 4-12: Heat rejection sub-system: open and closed wet and dry cooling towers and alternative heat sinks.

In the heat rejection sub-system different cooling tower types are applicable as **main coolers** (see Fig. 4-12). For given ambient conditions lowest cooling water temperatures are accomplished by utilizing an open wet cooling tower. A closed cooling water loop allows for less maintenance effort. In this case either a closed wet cooling tower or a dry air cooler may be chosen. The dry air cooler eliminates the formation of fog and legionella bacteria growth at the expense of an increase of the cooling water temperature compared to the wet cooling tower options. Apart from the heat transfer to the ambient air alternative heat sinks may be used in specific situations: A swimming pool offers both a reasonably low temperature level and the option of re-utilizing the reject heat of the sorption cooling process. As an alternative, geothermal systems may be used for dumping the reject heat: Options are ground heat exchangers, boreholes or ground water wells. Heat transfer to these geothermal installations during cooling mode of the system may have a positive impact on the system performance during the inverse operating mode, i.e. during heating operation with the thermally driven chiller operating in heat pump mode. When reject heat is stored underground during the cooling season the average annual ground temperature stabilizes at a higher value facilitating the extraction of ambient heat during the heating season.

The heat rejection via the main cooler may be assisted by an **auxiliary cooler** (see Fig. 4-13), allowing for re-utilization of the reject heat for heating of domestic hot water (“DHW preheating”) or a swimming pool. Other alternatives are the heat transfer to the exhaust air of an air-handling unit (“AHU”) or a latent heat store (“PCM storage”). The latter two options may offer reduced effort for the transfer of the reject heat to ambient in terms of parasitic energy consumption or operating cost. While the main cooler is continuously available, the capacity and availability of the auxiliary cooler may be limited. Therefore, the auxiliary coolers are installed in the cooling water line leaving the sorption chiller or in parallel to the main cooler. In any

case the main cooler assures the desired temperature drop of the cooling water, either by adjusting the flow rates through main cooler and auxiliary cooler or by setting the capacity of the main cooler accordingly.

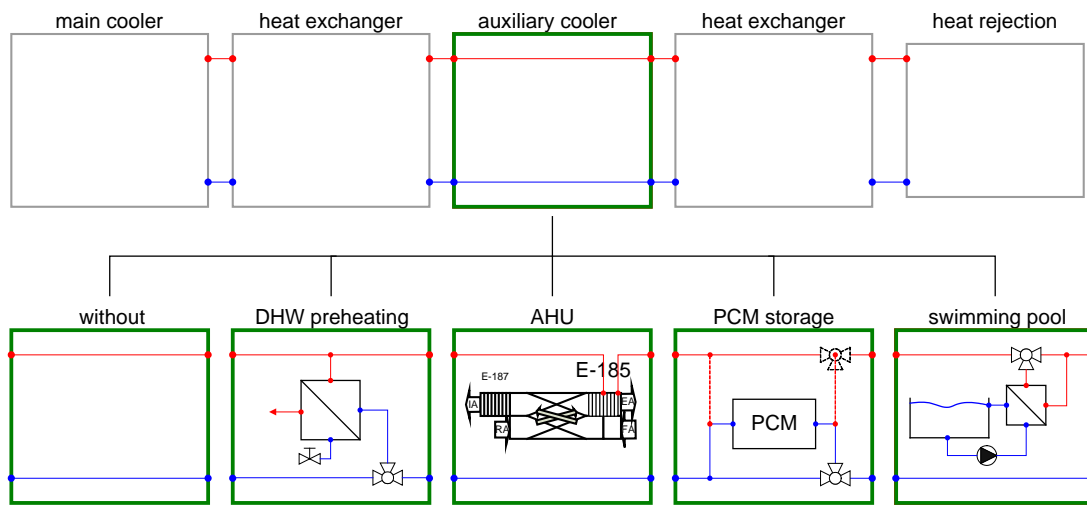

Fig. 4-13: Heat rejection sub-system: auxiliary coolers.

In conventional cooling installations open wet cooling towers are directly coupled to absorber and condenser of the chiller. In order to avoid fouling of the cooling water system due to intake of any pollutants from the open cooling tower, a **heat exchanger** may be installed (Fig. 4-14). Although the thermally driven chiller itself may to some extent tolerate this fouling effect, a heat exchanger is required when additional components like an auxiliary cooler are integrated into the cooling water system. Under certain circumstances a heat exchanger has to be placed between auxiliary heater and chiller.

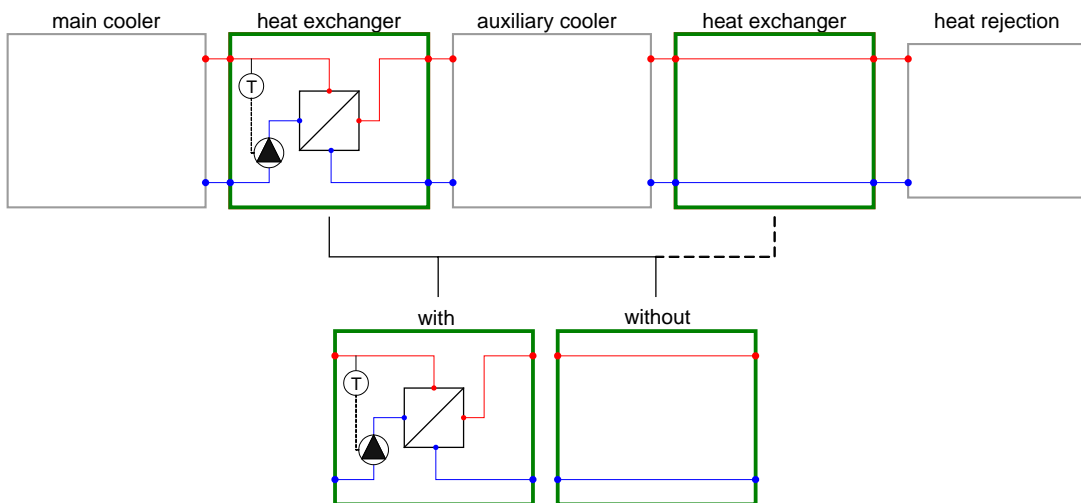

Fig. 4-14: Heat rejection sub-system: optional heat exchangers for separation of thermally driven chiller, auxiliary cooler and main cooler.

In heat pump systems the heat output at intermediate temperature is used as useful heat for space heating or other purposes. In that case instead of a heat rejection device a set of heating appliances may be installed, driven by a heating loop extracting heat of condensation and sorption from the sorption heat pump cycle. As shown in Fig.

4-15, heating can be provided by radiate heating via activated surfaces (floor heating, walls or ceilings), air-handling-units (AHU), fan coils or radiators.

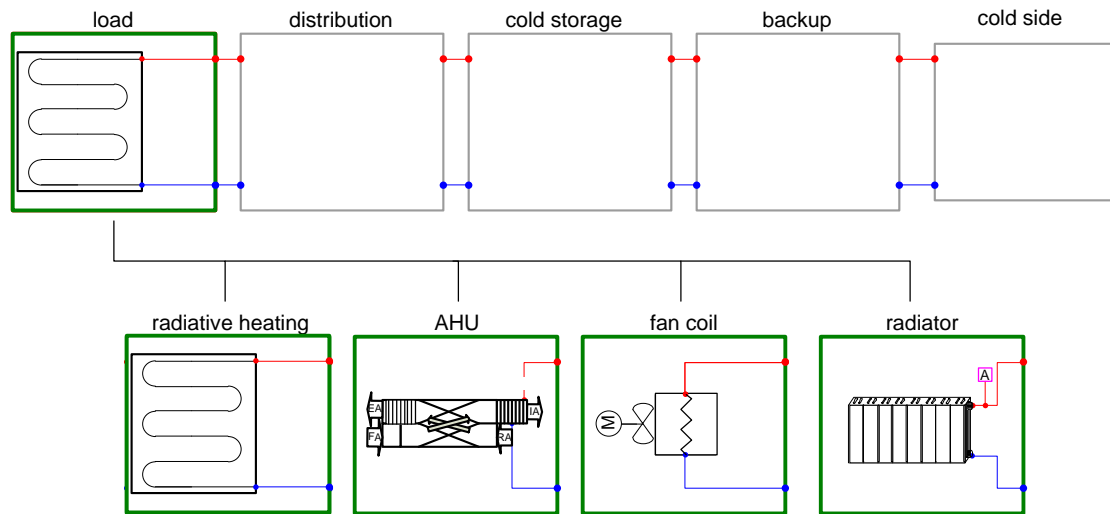

Fig. 4-15: Heating appliances for utilization of the heat output of the sorption heat pump at intermediate temperature level for space heating.

4.3.5 Heat input at low temperature level: Generation of cooling effect or uptake of ambient heat for heat pump operation

If the sorption heat pump serves as chiller, different **room-side installations** are applicable for the transfer of the cooling effect (see Fig. 4-16). For cooling and dehumidification of the room air either air-handling units (“AHU”) or fan coils may be chosen. For dehumidification chilled water temperatures below the dew point of the supply air are required. If sensible cooling only is desired elevated chilled water temperature is sufficient for the operation of radiative cooling surfaces (“radiative heating/cooling”). The same installation can be used for radiative heating during the heating season.

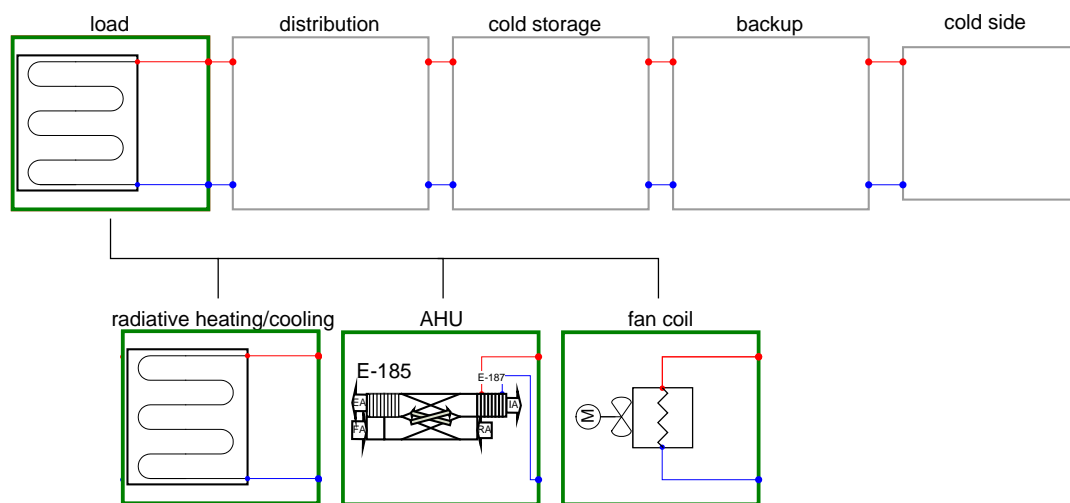

Fig. 4-16: Chilled water sub-system: Room-side installations for the transfer of the cooling effect.

For the **distribution of the chilled water** to the above cooling appliances different hydronic configurations are feasible (Fig. 4-17): In general a mixing valve between chilled water supply and return line is applied for adjusting the operating temperature of the room-side appliance (“single”). In distributed systems coolers of the same type are installed in parallel in order to assure equal operating conditions. In the graphs a second load is depicted by two concentric circles. In the configuration “parallel 1” for each loop a pump together with a mixing valve is installed. In configuration “parallel 2” the main chilled water pump at the inlet port of the distributor serves for circulation of the chilled water throughout the whole chilled water system. Temperature adjustment is accomplished by means of flow control by two-way valves in each sub-loop. If coolers of different types shall be operated with different chilled water supply temperature a serial configuration (“serial”) allows for stepwise utilization of the cooling effect. As a consequence, the serial concept allows for higher chilled water return temperature and enhanced performance and capacity of the chiller.

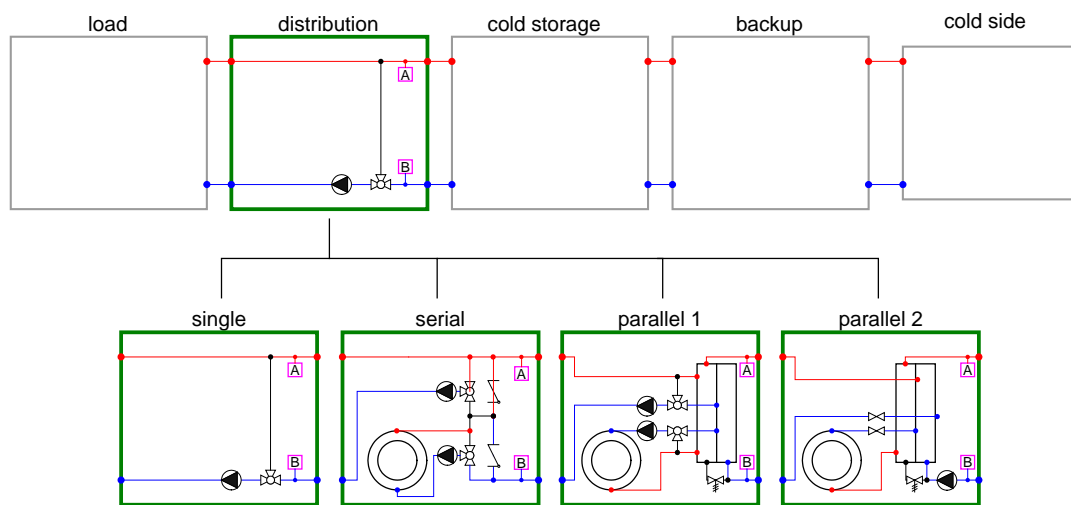

Fig. 4-17: Chilled water sub-system: Options for the distribution of the chilled water.

In the case of larger fluctuations of the cooling demand (which results in fluctuations of the volume flow between distribution and storage) a **cold storage** serves for levelling the chilled water consumption by decoupling the volume flow of the load and the chiller, and facilitates stable operation of the thermally driven chiller (Fig. 4-18). Predominantly chilled water is used as storage medium. The storage is either directly loaded (“cold storage 1” and “2”) or an internal heat exchanger (“cold storage 3”) serves for the separation of the primary and secondary cooling loop. In analogy to the solar sub-system, the configuration “storage 1” with direct link from chilled water production to the load allows for bypassing the cold storage. Consequently, the chilled water flow transiting the storage vessel is reduced and mixing of the storage volume is avoided. Again hydronic integration with minimum pressure drop is essential for avoiding parasitic flows in the chilled water system. The configuration “storage 3” induces a temperature loss between primary and secondary chilled water loop and is therefore not recommended. Yet, a separation of the hydronic loops by a heat exchanger may be required if an ice storage shall be applied. In the future the use of other phase change materials as storage medium or PCM slurries may gain increasing importance. As a result due to the latent heat effect a reduction of the storage volume in comparison to a chilled water tank is accomplished.

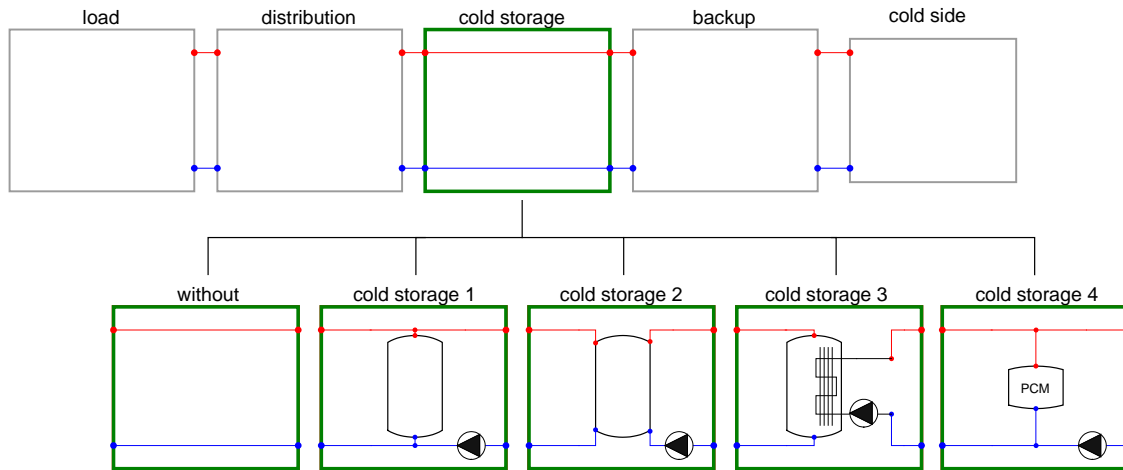

Fig. 4-18: Chilled water sub-system: Chilled water storage and latent cold storage (PCM, phase change material).

If a reliable chilled water supply has to be guaranteed – independently from the availability of the solar driving heat – a **backup cooling source** may be provided. For this purpose a compression chiller may be installed in the chilled water supply line. If the thermally driven chiller does not provide sufficient cooling capacity, the mechanical chiller is controlled in order to reach the desired chilled water supply temperature. As an alternative a ground water well or any other geothermal installation, e.g. a borehole or a ground heat exchanger, can serve as backup cooler (Fig. 4-19). During the winter the ground water well may be used as geothermal heat source for the system operating in heat pump mode, as discussed in the following section.

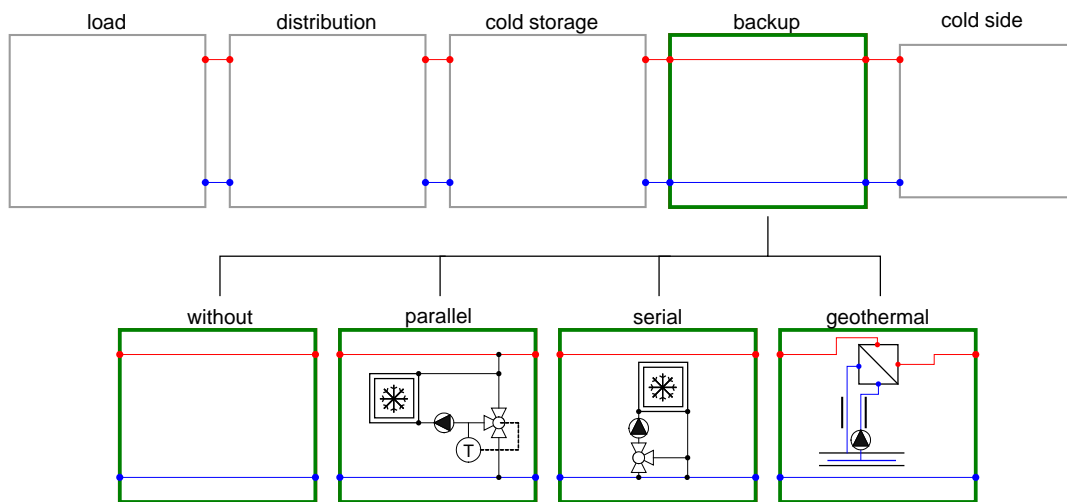

Fig. 4-19: Chilled water sub-system: Integration of a compression chiller or a ground water well as backup cooling source.

In heat pump operation ambient heat is supplied to the sorption cycle at lowest temperature level. Different types of heat sources can be used. If freezing of the refrigerant is not an issue, air-heat exchangers can be used for air-source heat pump operation. This is applicable for the working pair ammonia-water. With water as refrigerant the evaporation temperature has to stay above 0 °C. Thus utilization of ground water is a viable option with supply/return temperature about 10/5 °C. In

addition, boreholes can be used, if the heat extraction from the ground is limited in order to maintain sufficiently high heat source temperatures (Fig. 4-20).

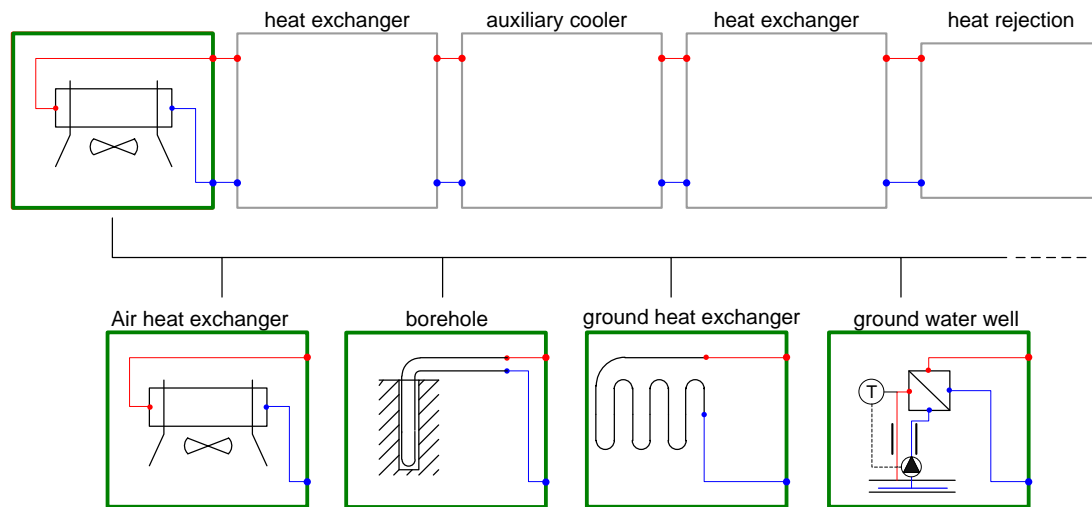

Fig. 4-20: Heat sources for heat pump operation: Air-heat exchanger, boreholes geothermal collectors (ground heat exchanger) or ground water well,

4.3.6 Selection guide

In the following tables a comparative characterization is given, summarizing the technical discussion in the previous sections. The list is not completed yet and will be extended with on-going research. However, it shows a remarkable amount of options for systems with thermally driven heat pumps and chillers.

Table 4-1: Selection guide for components of the generic system

	function or main characteristic	additional information
Driving heat input at highest temperature level		
driving heat		
direct-firing	heat generation from fossil fuel	
co-generation	motor engine, gasturbine, etc.	
district heat	central heat generation, distributed via heating network	
solar thermal	accumulation of solar heat	
flat plate collector	cost efficient	robust, reliable
vacuum-tube collector	low thermal losses	high collector efficiency, low collector area required
concentrating collector	optimum efficiency for direct radiation	high collector efficiency, suitable for double-effect chiller
heat exchanger	separation of hydraulic loops	
with	anti-freeze liquid in solar loop	negative impact on thermal performance due to driving temperature difference
without	measures for freeze-protection required	pure water as solar heat carrier or drain back system or water-glycol mixture directly supplied to sorption chiller
heat storage	storage of surplus solar heat	
storage 1	direct link between collector and heat consumer	simple construction, reduced flow facilitates stratification
storage 2	no bypass, all hot water flows pass through storage	simple construction, decouples volume flows, no parasitic flows
storage 3	not applicable	
storage 4	charging and discharging section-wise	switching valves for selction of heat storage section
storage 5	exact stratification	gravity loading system
storage 6	charging and discharging section-wise	switching valve for selction of heat storage section
storage 7	charging and discharging section-wise	switching valve for activation of additional storage volume
storage 8	enhanced storage capacity	adjustment of storage volume by supplementary installation of storage tanks
storage 9	latent heat storage: maximum storage density	operation with characteristic temperatures for loading and unloading
DHW (domestic hot weater)	tap water heating	
DHW 1	not applicable	
DHW 2	not applicable	
DHW 3	external heat exchanger	instantaneous tap water preparation
DHW 4	external tap water storage	storage covers load peaks
backup	auxiliary heat source	
parallel	hot water boiler	parallel installation, loading of heat storage possible
serial	hot water boiler	serial installation, boosts hot water supply temperature, no loading of heat storage
without		

	function or main characteristic	additional information
Heat output at intermediate temperature level:		
Heat rejection (waste heat) or useful heat output for space heating or other heat utilization		
useful heat output for space heating or other heat utilization		
radiative heating	activated surfaces	floor heating, walls, ceilings
air-handling units (AHU)	water/air heat exchange in central ventilation systems	
fan coils	water/air heat exchangers for local heat supply	
radiators	wall-mounted heating surfaces	
heat rejection, waste heat (main cooler)		
wet cooling open	best cooling capability, theoretic limit: wet bulb temperature	low cooling water temperature, consequently low driving hot water temperature for sorption chiller. water make-up required, risk of legionella infection and fog formation.
wet cooling closed	good cooling capability, increased cooling water temperature due to additional heat transfer	water make-up required, risk of legionella infection and fog formation.
dry cooling	reliable, trouble-free operation. only sensible cooling: elevated cooling water temperature	requires higher driving hot water temperature for sorption chiller. For water/LiBr chiller not applicable in hot climates.
swimming pool	re-utilization of the reject heat	increasing cooling water temperature due to limited storage capacity
ground heat exchanger	heat transfer to surface ground layer	high installation effort, low parasitic power demand
borehole	heat transfer to deep ground	high installation effort, low parasitic power demand
well	heat transfer to ground water	high installation effort, low parasitic power demand
heat exchanger		
with	separation of hydraulic loops	
without	avoids intake of pollutants from open cooling loop	
auxiliary cooler		
without	re-utilization of the reject heat	
DHW preheating	tap water heating	substitutes fresh heat (solar heat or fossil fuel)
AHU	heat transfer to exhaust air of AHU	replaces dry air-cooler
latent heat storage (PCM)	storage of waste heat	facilitates application of dry air-cooler even in hot climates
swimming pool	heating of pool water via heat exchanger	substitutes fresh heat (solar heat or fossil fuel)
heat exchanger		
with	separation of hydraulic loops	
without	separation from water/glycol loop	

	function or main characteristic	additional information
Heat input at low temperature level:		
Generation of cooling effect or uptake of ambient heat for heat pump operation		
ambient heat source for heat pump operation		
air-heat exchanger	utilization of ambient air	low heat source temperature: selection of refrigerant, defrosting required
ground water	ground water well with suction and discharge bore	constant heat source temperature
borehole	vertical ground heat exchanger	
geothermal collector	horizontal ground heat exchanger	low heat source temperature
cooling load		
radiative heating/cooling	only sensible cooling, no dehumidification, heating in winter	moderate temperature level for heating and cooling, chilled water temperature above dewpoint
AHU	heating, cooling and dehumidification	low chilled water temperature required for dehumidification
fan coil	heating, cooling and dehumidification	condensate handling required for dehumidification
distribution		
single	single cooling appliance (see options "load")	pump and mixing valve for control of entering chilled water temperature. No chilled water pump at chiller port required.
serial	cascade of cooling appliances operating at different temperature levels	chilled water return flow from first cooler is used in following cooler, supply temperatures are controlled individually
parallel 1	parallel installation of cooling appliances	pump and mixing valve for individual setting of supply temperatures, chilled water supply to distributor by chilled water pump at chiller port
parallel 2	parallel installation of cooling appliances	pump and flow control for individual setting of supply temperatures, chilled water supply to distributor by chilled water pump at chiller port
cold storage		
without		
buffer 1	direct link between chilled water generation and load	simple construction, reduced flow facilitates stratification
buffer 2	no bypass, all chilled water flows pass through storage	simple construction, decouples volume flows, no parasitic flows
buffer 3	storage loaded by internal heat exchanger, ice storage	chiller operates at lower temperature, negative impact on chiller efficiency and/or higher driving temperature required
buffer 4	latent cold storage	hydraulic concept to be defined
cooling backup		
without		
parallel	compression chiller, parallel integration	split flow to different chillers, sorption cooling covers base load only
serial	compression chiller, serial integration	sorption chiller designed for full load, backup chiller provides final cooling when solar driving heat not sufficient
geothermal	free cooling by heat transfer to geothermal source	optimum energy saving

4.3.7 Outlook and dissemination

The generic system was also developed within Task 38. For more information see (Becker 2009). There further examples and an investigation of control strategy issues are discussed. The work was also promoted within Annex 34 in the following conferences, publications and committees:

- DIN-Workshop about norming of solar cooling in Germany (Helm 2012)

It will further influence the work of IEA Task 48 (Mugnier 2012).

4.4 Energy Flows Representation

The last approach reported is focused on the energy flows, both thermal and electric, established among the system’s components and between the plant and the “rest of the world”: building, electricity grid and all other energy sources (renewable and fossil) exchanging energy with the system. The method has been developed in close collaboration with IEA-SHC Task44 - HPP Annex 38.

4.4.1 Source Sink Approach

As in the previous case, the approach is based on all components possibly installed in the system, instead of all possible configurations the system could adopt. In particular, it is centred on a source-sink approach, in which any component can virtually supply any other (source) with thermal or electric energy, or behaves as a sink of energy from any other.

The clear benefit of this approach is the degree of freedom left to the description of the connections.

To easily manage the definition of the connections, an excel table has been elaborated where the first column shows all possible elements of the system, treated as sources, and the first row reports the same elements regarded as sinks (see Fig. 4-21 and Fig. 4-22).

Source		Sink																		
		Electricity	Energy Carrier	Sun	Ground	Air	Water	Waste Heat	Solar Collectors	Ground Probes	Air Heat Exchanger	Water Heat Exchanger	Waste Heat Exchanger	Primary Storage	Rejection Storage	Hot Backups	HP	Cold Backups	Secondary Storage	
	Source	EI	EC	Su	Gr	Ar	Wt	He	SC	GP	AH	WH	HH	PS	RS	HB	HP	CB	SS	
Electricity	EI										x									
Energy Carrier	EC																			
Sun	Su								x											
Ground	Gr									x										
Air	Ar																			
Water	Wt																			
Waste Heat	He																			
Solar Collectors	SC													x						
Ground Probes	GP																			
Air Heat Exchanger	AH																			
Water Heat Exchanger	WH																			
Waste Heat Exchanger	HH																			
Primary Storage	PS																			
Rejection Storage	RS																			
Hot Backups	HB																			
HP	HP																			
Cold Backups	CB																			
Secondary Storage	SS																			
Heat Distribution	HD																			
DHW Distribution	WD																			
Cold Distribution	CD																			

Fig. 4-21: Source-Sink table

Source	Sink						Heat Distribution	DHW Distribution	Cold Distribution	Solar Pump	Secondary Pump	Distribution Pump		
	Electricity	Energy Carrier	Sun	Ground	Air	Water								
	EI	EC	Su	Gr	Ar	Wt	HD	WD	CD	P1	P2	PD		
Electricity	EI									x				
Energy Carrier	EC										x			
Sun	Su													
Ground	Gr													
Air	Ar													
Water	Wt													
Waste Heat	He													
Solar Collectors	SC													
Ground Probes	GP													
Air Heat Exchanger	AH													
Water Heat Exchanger	WH													
Waste Heat Exchanger	HH													
Primary Storage	PS													
Rejection Storage	RS													
Hot Backups	HB						x							
HP	HP						x							
Cold Backups	CB													
Secondary Storage	SS							x						
Heat Distribution	HD													
DHW Distribution	WD													
Cold Distribution	CD													

Fig. 4-22: Close-up of the source-sink table

The elements are grouped together with colours:

- in grey **TRADED ENERGY** input/outputs to/from the systems are accounted for
 - Electricity
 - Any other Energy carrier fossil or renewable: gas, oil, wood, DHC.
- in dark green **FREE AVAILABLE RENEWABLE ENERGY SOURCES** are reported
 - Sun
 - Ground
 - Air
 - Water
 - Waste heat
- In light green the **HEAT EXCHANGERS** between the RES and the systems are shown
 - Solar collectors
 - Ground probes
 - Air/water, Air/vapour heat exchangers
- In dark pink the **STORAGES** between the RES and the active components (heat pumps and backups) are set
 - **Primary storage** – so defined because it could be used as a hot or cold one depending on the operation mode
 - **Heat rejection storage** (i.e. latent heat storage to store rejected heat to be eliminated at nights)
- In light pink the **HOT BACKUPS**. Despite the possibility of facing systems with multiple hot backups, they are all grouped together since the focus is on the heat pump. Hot backups can be:
 - Boilers

- Compression heat pumps
- CHP units
- In orange the **THERMALLY DRIVEN HEAT PUMPS**
- In light blue the **COLD BACKUPS** are reported
- In dark blue the **SECONDARY STORAGE**
 - Cold storage in cooling applications
 - Hot and/or DHW storage in heating applications
- In dark red the **BUILDING’S LOADS**.

On the first row, next to the building’s loads, additional cells are left empty for pumps and fans to be added: they are only considered as electric energy sinks (see Fig. 4-22).

Any element is fully identified by a two-letters code: first two letters of the name (Sun = Su) or first letters of a composite name (Solar Collectors = SC). In this way any component is marked with an intuitive abbreviation: this will be then used to identify also all energy fluxes through the system. In particular the flux is named as: “source”.”sink”.

The system is described by marking the cross between the specific sources and sinks: in Fig. 4-22 the fluxes from the HP and hot backups to the heating distribution, and from the secondary storage to the DHW distribution, are shown as an example. Obviously the large majority of the cells remain unused. Therefore an automated procedure simplifies the main table and prepares a reduced one that only reports the envisaged fluxes and names them with the specific abbreviations (see Fig. 4-23).

Source		Sink											
		Solar Collectors	Ground Probes	Air Heat Exchanger	Primary Storage	Hot Backups	HP	Secondary Storage	Heat Distribution	DHW Distribution	Solar Pump	Secondary Pump	Distribution Pump
		SC	GP	AH	PS	HB	HP	SS	HD	WD	P1	P2	PD
Electricity	EI			EI.AH		EI.HB	EI.HP				EI.P1	EI.P2	EI.PD
Sun	Su	Su.SC											
Ground	Gr		Gr.GP										
Solar Collectors	SC				SC.PS								
Ground Probes	GP						GP.HP						
Primary Storage	PS						PS.HP						
Hot Backups	HB							HB.SS	HB.HD				
HP	HP							HP.SS	HP.HD				
Secondary Storage	SS									SS.WD			

Fig. 4-23: Reduced source-sink table

4.4.2 Energy Flow Chart

The source-sink table fully describes the system from the energy flows point of view. However it is not so intuitive, from the visual point of view, as needed. Therefore, an additional representation is used to assist the first. The Energy Flow Chart is generated (again in the excel worksheet) starting from the source-sink table: all system elements in the table are reported on a diagram (as in Fig. 4-24, with consistent colours). The traded energy is reported on the left side, the RES are reported on top and the building loads are on the right side. The system components are arranged at the centre of the diagram.

Heat and electricity fluxes are represented with arrows among the elements (from the source to the sink) accordingly to the source-sink table. Electricity fluxes are represented in grey, thermal energy is displayed in dark red. All arrows are also identified correspondingly to the source-sink table.

Since electricity fluxes to pumps and fans would pack the diagram too much in case of complex systems, those components are shown as blue dots to be displaced on the diagram onto the respective energy fluxes: themselves represent the respective electricity consumption.

A second clear advantage of this approach is that boundaries of the system and subsystems can be represented on the diagram and input/output energy fluxes can be detected, justifying the performance figures calculation and the meters needed for the acquisition of the needed data.

In Fig. 4-24, two exemplary boundaries have been sketched: the first around the HP and hot backup, the second around the entire system. Entering and leaving fluxes are clearly different and so are the meters to be used to describe the system and the performance figures computed.

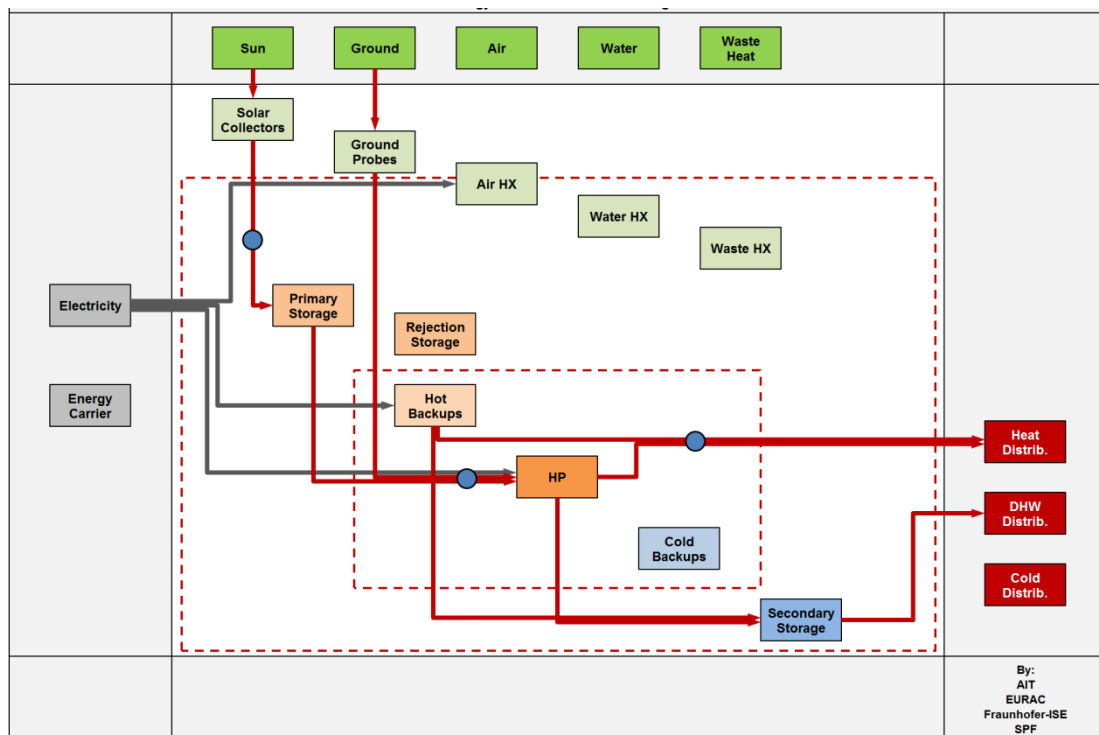

Fig. 4-24: Energy Flow Chart. Method with permission of IEA- SHC Task 44 -HPP Annex 38, 2011

4.4.3 Data Acquisition Tables

Finally three worksheets are made available to save acquisition data.

In the first one, thermal energy data are reported: a row is generated for any thermal energy flux shown in the energy flow diagram (see Fig. 4-25). The source and the sink are again reported to identify the flux; columns can be filled in with monthly and yearly data.

The second worksheet is used to report on electric energy data shown in the Energy Flow Chart. The structure of the sheet is the same as for the thermal energy information (see Fig. 4-26).

The acquisition of all the quantities permits a complete characterization of the system. Most of the monitoring systems available are not designed to record all the mentioned information due to the excessive cost. For this reason, rows are generated to group together subsystems, i.e. for the electricity sheet, the “total electricity to the system”, “total electricity to the pumps” and “total electricity to the HP” are prepared.

The two stated worksheets allow showing which the monitored quantities at the specific plant are. They do not report on the quantities that have to be measured to compute the needed performance figures. For this purpose, a third sheet is generated where the needed incoming and outgoing fluxes are reported for any boundary sketched in the Energy Flow Chart.

Fig. 4-27 shows a close-up of such a sheet: electricity input, thermal energy input and thermal energy output are reported for the two boundaries in this example, the System boundary (the largest one) and the HP boundary (including HP and the backups).

Those quantities are needed to compute performance figures as SPF or RER and have to be measured. Therefore, the last sheet gives a clear indication on the meters to be used (and their position in the plant) for the assessment of the system performance.

Thermal Energy Data	Nomenclature	Yearly Data [kWh]	January [kWh]	February [kWh]	March [kWh]
Sun to Solar Collectors	Su.SC				
Ground to Ground Probes	Gr.GP				
Total Renewable Energy to System	RES.System				
Solar Collectors to Primary Storage	SC.PS				
Ground Probes to HP	GP.HP				
Total RE harvested to System	REH.System				
Primary Storage to HP	PS.HP				
Hot Backups to Secondary Storage	HB.SS				
Hot Backups to Heat Distribution	HB.HD				
Total Hot Backups to System	HB.System				
HP to Secondary Storage	HP.SS				
HP to Heat Distribution	HP.HD				
Total HP to System	HP.System				
Secondary Storage to DHW Distribution	SS.WD				

Fig. 4-25: Thermal energy data acquisition table

Electric Energy Data	Nomenclature	Yearly Data [kWh]	January [kWh]	February [kWh]	March [kWh]
Electricity to Air Heat Exchanger	EI.AH				
Electricity to Hot Backups	EI.HB				
Electricity to HP	EI.HP				
Electricity to Solar Pump	EI.P1				
Electricity to Secondary Pump	EI.P2				
Electricity to Distribution Pump	EI.PD				
Total Electricity to System	EI.System				
Total Electricity to Pumps	EI.Pumps				
Total Electricity to HP	EI.HP				

Fig. 4-26: Electric energy data acquisition table

Boundary	Flux	Energy Flux	Nomenclature	Yearly Data	January	February	March
				[kWh]	[kWh]	[kWh]	[kWh]
System	Electricity IN	Electricity to Air Heat Exchanger	EI.AH				
System	Electricity IN	Electricity to Hot Backups	EI.HB				
System	Electricity IN	Electricity to HP	EI.HP				
System	Electricity IN	Electricity to Solar Pump	EI.P1				
System	Electricity IN	Electricity to Secondary Pump	EI.P2				
System	Electricity IN	Electricity to Distribution Pump	EI.PD				
System	Thermal En. IN	Solar Collectors to Primary Storage	SC.PS				
System	Thermal En. IN	Ground Probes to HP	GP.HP				
System	Thermal En. OUT	Hot Backups to Heat Distribution	HB.HD				
System	Thermal En. OUT	HP to Heat Distribution	HP.HD				
System	Thermal En. OUT	Secondary Storage to DHW Distribution	SS.WD				
HP	Electricity IN	Electricity to Hot Backups	EI.HB				
HP	Electricity IN	Electricity to HP	EI.HP				
HP	Electricity IN	Electricity to Secondary Pump	EI.P2				
HP	Electricity IN	Electricity to Distribution Pump	EI.PD				
HP	Thermal En. IN	Ground Probes to HP	GP.HP				
HP	Thermal En. IN	Primary Storage to HP	PS.HP				
HP	Thermal En. OUT	Hot Backups to Secondary Storage	HB.SS				
HP	Thermal En. OUT	Hot Backups to Heat Distribution	HB.HD				
HP	Thermal En. OUT	HP to Secondary Storage	HP.SS				
HP	Thermal En. OUT	HP to Heat Distribution	HP.HD				

Fig. 4-27: Performance figures calculation table

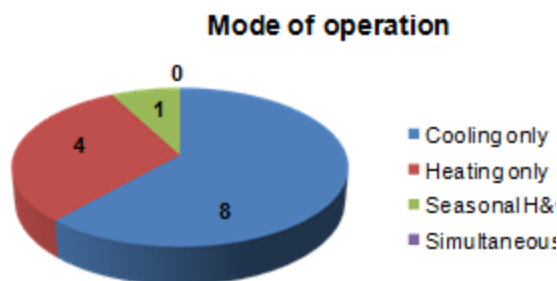

Fig. 4-28: Templates classified in Mode of operation

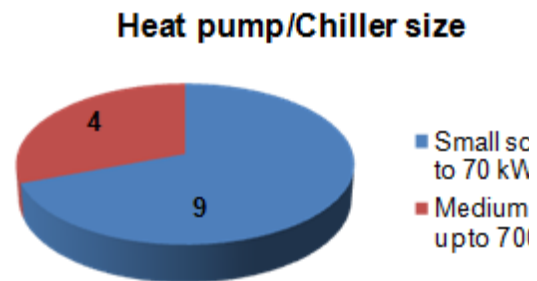

Fig. 4-29: Templates classified in Heat pump/Chiller size

5 DEMONSTRATION PLANTS

The present report deals with the end-use applications of thermally driven heat pumps. The target is to present practical experiences of existing worldwide installations in order to enhance the theoretical knowledge about system layouts, sizing of main components and control strategies.

The report starts with the explanation of the tool used for collecting data of demonstration plants. Objectives, structure and typology of attended results are described in details.

After that, the templates compiled by the project partners are attached.

5.1 Template of Demonstration Plant

The variety of analysed plants in terms of size, system layout, application, components installed and control strategies, makes quite difficult the collection of their relevant data in a standardized way.

The necessity to have information of the same type comes from need to have comparable results. With this regard, a template for collecting data of demonstration plants uniformly has been developed within the project HPP Annex34 and distributed among the project partners.

Based on the experience acquired in other international projects, such as SOLAIR and SHC Task 38, this template is structured in five main parts:

- Application
- TDHP & Energy system
- Control Strategies
- Scheme and Representation
- Monitoring data and Performance Evaluation

5.1.1 Application

In this section, general information about the application is required. A brief description containing the purpose of the building – i.e. school, office, residential building, etc... –, general information such as location, data of construction, history notions, renovations, original purpose (if different from the current one), etc..., data on architectural aspects – i.e. rooms, square or cubic meters of space heating and cooling – building energy rating, shall be provided.

Besides having detailed information about the end user, the aim of this part is to create statistics on the correlations between the typology of thermally driven heat pumps installed and their field applications.

In addition, a table summarizing all these information is also provided (see Fig. 5-1). It serves as a sheet of the whole plant. In it, some dropdown menus allow the compiler of the template to choose among different options. The possibility to add alternative options is also given.

Type of building	Choose an item	Please insert here a Picture of the Building/Application
Location [City, Country]	Choose an item	
In operation since [year]	office	
System operated by [Brand]	residential	
TDHP used for Space Heating?	commercial building	
TDHP used for Space Cooling?	industrial building	
TDHP used for DHW preparation?	other....	
Chilling Power of TDHP [-] kW		
Heating Power of TDHP [-] kW		
Air-conditioned area [-] m ²		

Fig. 5-1: Sheet containing the main features of the plant

5.1.2 TDHP and Energy System

In this section, detailed information about the thermally driven heat pump and the energy system in which it is installed is required.

Also in this case, it is provided for a descriptive part of the plant, i.e. a text containing data about the technology of thermally driven heat pump, its heat sources and sinks, the backups and storages systems, etc.; and a compilation part, consisting of several sheets containing dropdown menus to be compiled with specific technical data.

The section is structured in such a way that the description of the whole system is based on the thermally driven heat pump. The main components installed in the plant like the distribution systems, the heat rejection system, the backups, etc... are introduced on the basis of the internal heat exchangers of the appliance and of the seasons (winter/summer period). An example is given in Fig. 5-2 and in Fig. 5-3 where, depending on the season (summer or winter) the evaporator of the thermally driven heat pump can be connected with the distribution system or with a component that serves as heat source. In this way, it is possible to get information about the entire system (e.g. about the distribution system: technology, type, size, capacity) and, at the same time, to acquire notions about the different ways to integrate the thermally driven heat pump in a system of heat sources and sinks.

Nevertheless, redundancies can occur especially for the generator of thermally driven heat pump or when the same component is used as heat source or sink during the two seasons - i.e. the main features of the component are described twice in the same document with the exception of the operation temperature levels).

3.1.3 Evaporator

a. Summer Period: *Distribution System*

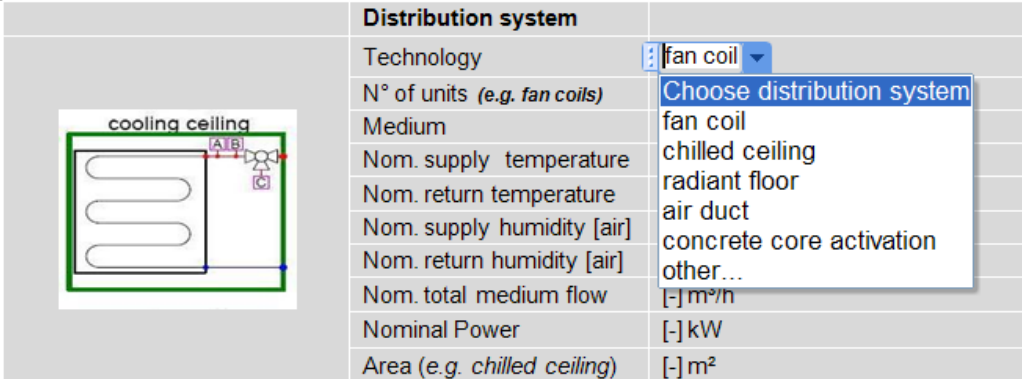

The figure shows a schematic of a cooling ceiling system on the left, labeled 'cooling ceiling'. It features a rectangular area with a serpentine pipe layout. A fan coil unit is connected to the system, with arrows indicating flow directions. To the right of the diagram is a table titled 'Distribution system' with various parameters and their corresponding values or units. A dropdown menu is open for the 'Technology' field, showing 'fan coil' selected and a list of other options: 'Choose distribution system', 'chilled ceiling', 'radiant floor', 'air duct', 'concrete core activation', and 'other...'. The table also includes units for flow and power.

Distribution system	
Technology	fan coil
N° of units (e.g. fan coils)	Choose distribution system
Medium	fan coil
Nom. supply temperature	chilled ceiling
Nom. return temperature	radiant floor
Nom. supply humidity [air]	air duct
Nom. return humidity [air]	concrete core activation
Nom. total medium flow	[-] m³/h
Nominal Power	[-] kW
Area (e.g. chilled ceiling)	[-] m²

Fig. 5-2: Description of the system on the basis of the TDHP evaporator. *Summer period: Distribution System*

b. Winter Period: Heat Sources

Heat Sources	
Technology	Choose heat source
Heating Power	Choose heat source
Operation temperature	geothermal heat solar heat air
a) Solar Thermal	
Collector type	other...
Brand of collector	[brand]
Collector area	Choose Collector Area [-] m ²
Type of mounting	Choose Type of Mounting
Tilt angle, orientation	[-] [°]
Collector fluid	Choose Collector Medium [%]
Typical operation temperature	[-] °C driving temperature for chiller operation
Flow Control	Choose Flow Control
Used for DHW preparation	yes
b) Geothermal	
Typology	Choose typology
Nom. Electricity Consumption	[-] kW
Nom. supply temperature	[-] °C
Nom. return temperature	[-] °C
Nom. total medium flow	[-] m ³ /h

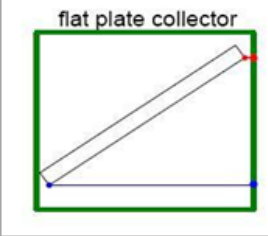

flat plate collector

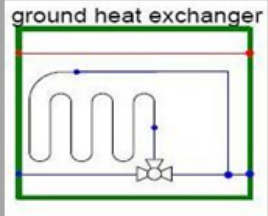

ground heat exchanger

Fig. 5-3: Description of the system on the basis of the TDHP evaporator winter period: Heat Sources

In the first column of each sheet (see Fig. 5-2 and Fig. 5-3), it is also required the insertion of the icons representing the technologies described in the other two columns. Then, in the section “Scheme and Representation”, they will be combined for hydronic representation of the whole plant.

5.1.3 Control Strategies

This section is dedicated to the only control strategies since they hold a key role both on the overall system performance and on the performance of the single components like the thermally driven heat pump.

The aim is to identify the control strategies currently employed in the existing plants and to use them as basis for the development of optimized control strategies (through simulations for instance). They are collected on the seasonal basis (i.e. summer and winter).

5.1.4 Scheme and Representation

In this section, the designs of energy plant are required. They allow understanding how the thermally driven heat pump is integrated into the system – i.e. sizes of the main components and hydronic connections – and creating a sort of database useful for the identification of the typical system layouts.

Besides the designs, the hydronic representation based on the method developed in “IEA Task38” project is also required. According to that, the entire plant is

represented as a function of the three main heat exchangers of the machine – i.e. generator, condenser/absorber and evaporator. In this perspective, the system components are seen as “auxiliaries” of the machine. For the representation, the icons inserted in the first column of the sheets above described are used. Since, in this project, the thermally driven heat pumps are considered not only for cooling applications, but also for the space heating and DHW preparation, the hydronic connections can be different depending on the functional scheme – i.e. *cooling & DHW, heating & DHW*. For this reason, the representation is done both for the summer and winter season (the yearly operation of the system is considered).

An example is given in Fig. 5-4 and Fig. 5-5, where the summer and winter functional schemes of a plant installed in a brewery in Graz (Austria) are shown.

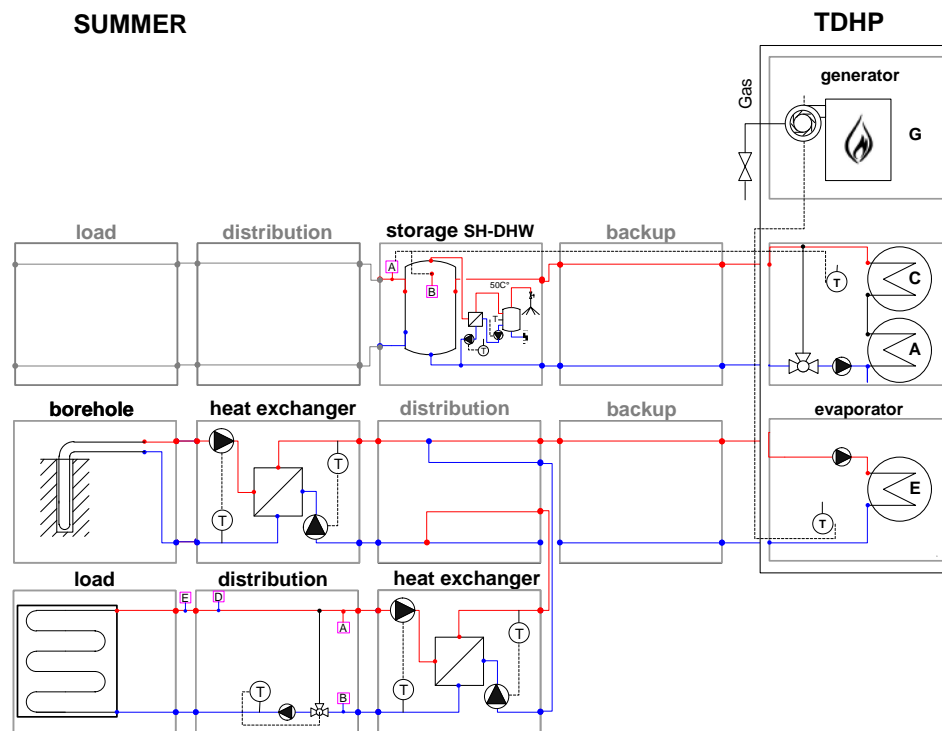

Fig. 5-4: Hydronic representation of a plant installed in the brewery’s storehouse in Graz
 (A) - summer season: Cooling and DHW functional scheme Source: TU Graz

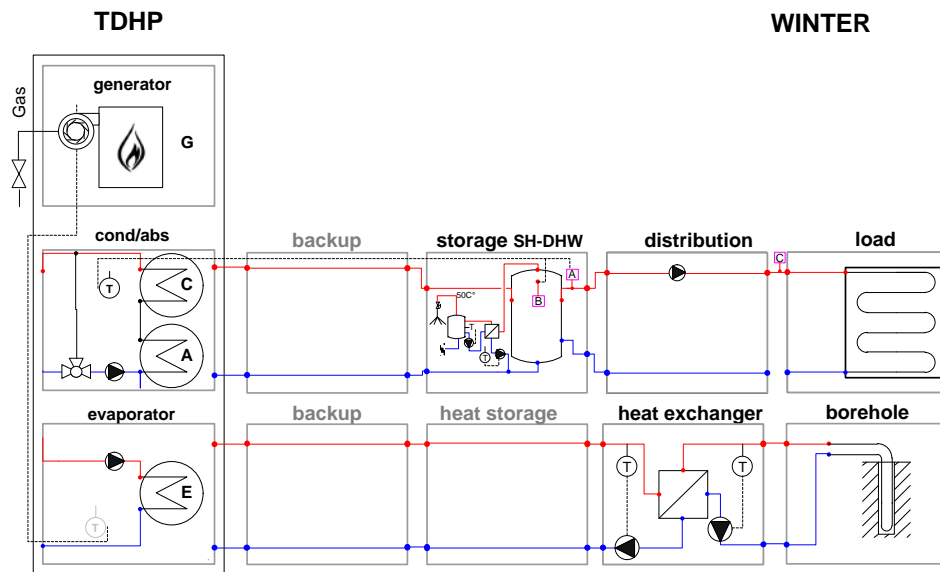

Fig. 5-5: Hydronic representation of a plant installed in the brewery's storehouse in Graz (A) - winter season: Heating and DHW functional scheme. Source: TU Graz

5.1.5 Monitoring data and Performance evaluation

This last section of the template deals with the monitoring and the performance evaluation of the examined plant.

Besides information about the monitoring period – from... until... - and monitoring equipment – typology and uncertainty (if known) of the sensors installed and their placement in the plant -, yearly data of the monitored quantities are required.

In support of the present template, an excel files based on the source/sink approach (see the report “*System Technology*”) has been developed. It allows achieving, on one hand, the “*Tabular*” representation and Energy Flow Chart of the examined plant (see the report “*System Technology*”); on the other hand, collecting monthly and yearly data. These last are carried in the template.

Examples of the representation obtained by this file are shown in Fig. 5-6 and Fig. 5-7.

Functional Scheme: DHW & Heating

Source		Sink				
		Ground Heat Exchanger	Primary Storage	TDHP	Heating Distribution	DHW Distribution
		Gh	PS	TD	Dh	Dw
Electricity	EI			EI.TD		
Energy Carrier	Fu			Fu.TD		
Ground	Gr	Gr.Gh				
Ground Heat Exchanger	Gh			Gh.TD		
Primary Storage	PS				PS.Dh	PS.Dw
TDHP	TD		TD.PS			

Fig. 5-6: Example of Tabular representation. Winter season: Heating and DHW functional scheme of a plant installed in the brewery’s storehouse in Graz (A) - Source: TU Graz

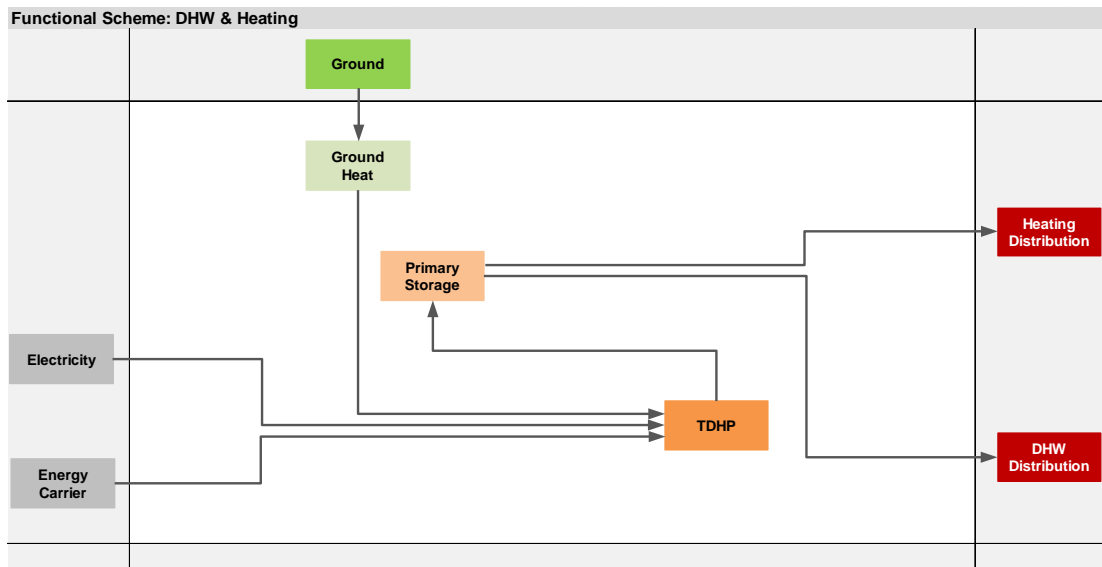

Fig. 5-7: Example of Energy Flow Chart. Winter season: Heating and DHW functional scheme of a plant installed in the brewery’s storehouse in Graz (A) - Source: TU Graz

Concerning the performance evaluation instead, the 1st level of the “Monitoring procedure for Solar Cooling systems” developed in IEA Task38 has been adapted to the scope of Annex34. At this level, the performance figures are defined on a control volume around the whole system. They are:

5.2 Demonstration Plants

Through the template above explained, the data of 13 demonstration plants have been collected. Nine completely filled templates are attached in Appendix 6.3. In the following an overview is given:

- ISE (Germany):

- @ISE: *Solar cooling* (8 kW Sortech adsorption chiller), also heat pump mode (20 kW)
- @ISE canteen: *Tri-generation* (2 x 5.5 kW Sortech adsorption chiller), no heat pump mode
- TU Berlin (Germany):
 - @UBA Dessau: *Solar Cooling* (69 kW Nishiyodo adsorption chiller), no heat pump mode
 - @Office building (Berlin): *District heat driven cooling* (50 kW TUB/ZAE adsorption chiller), no heat pump mode
- TU Graz (Austria):
 - @Storehouse of a brewery (Graz): *Direct fired heating* (2 x 37 kW Helioplus (Robur)), no cooling mode of TDHP
- AIT (Austria):
 - @Office building (Vienna): *Solar Cooling* (7.5 kW Sortech adsorption chiller), no heat pump mode
- EURAC (Italy):
 - @EURAC: *Solar Cooling + Tri-generation* (300 kW Thermax adsorption chiller), no heat pump mode
 - @Office building (Bolzano): *District heat driven cooling* (35 kW Yazaki adsorption chiller), no heat pump mode
- ZAE BAYERN (Germany):
 - @Municipal Composting Plant (Warngau/Munich): *Direct fired heating* (607 kW Thermax adsorption heat pump), no cooling mode
 - @Thermal Swimming pools (Bodenseetherme): *Tri-generation* (701 kW Thermax double-effect/single-effect adsorption heat pump), no cooling mode
 - @Residential building (Munich): *District heat driven heating with solar seasonal storage* (548 kW Thermax adsorption heat pump), no cooling mode
 - @ZAE: *Solar cooling* (10 kW Sonnenklima adsorption chiller) + PCM storage, no heat pump mode
- CanmetENERGY (Canada):
 - @Residential building (Ottawa): *Tri-generation* (Micro CHP and Yazaki adsorption chiller), no heat pump mode, TRNSYS simulation only

Two of the TDHPs are directly fired and 11 are indirectly fired (see Fig. 5–8). About the last, five are solar cooling applications, four are driven by a CHP unit and three are district heat driven (one is driven by solar thermal and CHP unit, see Fig. 5–9).

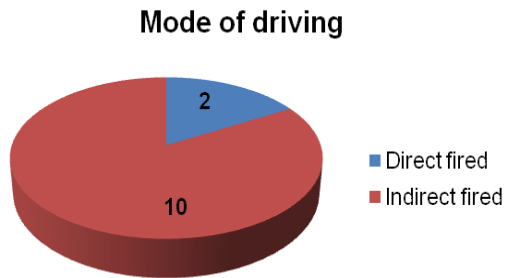

Fig. 5-8: Templates classified in Mode of driving

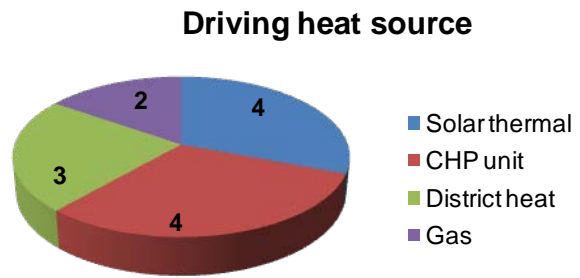

Fig. 5-9: Templates classified in Type of driving heat source

Of the 13 TDHPs one is used in heating mode in winter and in cooling mode in summer. Eight are only used for cooling and four are only used for heating. None is used for heating and cooling simultaneously (see Fig. 5-10). Two thirds Fig. 4-28). Nine of the TDHPs are small scaled. They have a cooling or heating capacity lower than 70 kW. Four have a higher cooling or heating capacity up to 700 kW (see 5-11). Fig. 4-29).

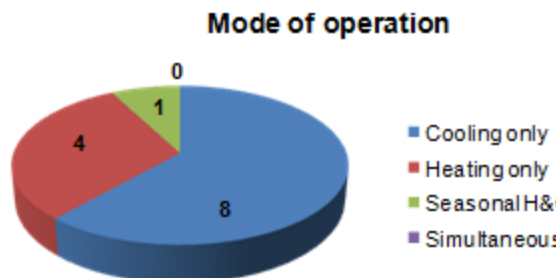

Fig. 5-12: Templates classified in Mode of operation

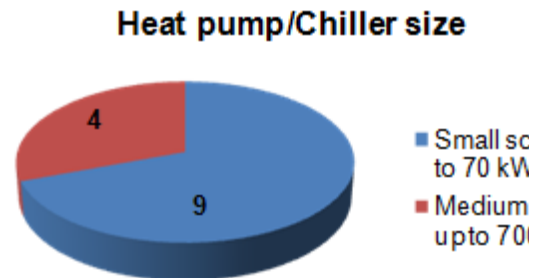

Fig. 5-13: Templates classified in Heat pump/Chiller size

6 APPENDIX

6.1 National projects and contributions

The work within Annex 34 was funded by national contributions. A list of the participating countries, the participating corporations and their research projects can be found in Table 6-1.

Table 6-1: Funding list for Annex 34

Country	Company	Project name	project funding reference number	funding agency
Austria	Graz University of Technology	Teilnahme IEA AHP Annex 34 - "Thermally driven heat pumps" InnoGen - "Innovative Generatorkonzepte für hocheffiziente direkt befeuerte Ammoniak / Wasser - Absorptionswärmepumpe"	819430, 832758 (Annex 34); 821858 (InnoGEN)	bmvit (Bundesministerium für Verkehr, Innovation und Transport) FFG (Österreichische Forschungsförderungsgesellschaft mbH)
Austria	Arsenal	Teilnahme IEA AHP Annex 34 - "Thermally driven heat pumps" InnoGen - "Innovative Generatorkonzepte für hocheffiziente direkt befeuerte Ammoniak / Wasser - Absorptionswärmepumpe"	819430, 832758 (Annex 34)	bmvit (Bundesministerium für Verkehr, Innovation und Transport) FFG (Österreichische Forschungsförderungsgesellschaft mbH)
Canada	Natural Resources Canada	Integration of Cogeneration and Heat Driven Cooling Systems	PERD project F22.003(BE)	Office of Energy Research and Development / Natural Resources Canada
France	gdfsuez	no funding	N/A	N/A
Germany	Fraunhofer-Institute for Solar Energy Systems ISE	Entwicklung einer Adsorptionskältemaschine mit hoher Leistungsdichte	0327423B	Federal Ministry of Economics and Technology BMWi
Germany	Solarnext	No funding	N/A	N/A
Germany	Viessmann	Entwicklung eines innovativen gasbetriebenen Zeolith-Heizgerätes; Ein Beitrag zur Steigerung der Energieumwandlungseffizienz und Emissionsminderung	0327435A and 0327435B	Federal Ministry of Economics and Technology BMWi

Country	Company	Project name	project funding reference number	funding agency
Germany	SorTech			
Germany	Technical University of Berlin	Verwendung von ionischen Flüssigkeiten in Absorptionskälteanlagen	0327472A	Federal Ministry of Economics and Technology BMWi
Germany	Zentrum für angewandte Energieforschung Bayern ZAE	Absorptionskältemaschine auf Basis kompakter Plattenapparate	0327875A	Federal Ministry of Economics and Technology BMWi
Italy	CNR-ITAE Institute for Advanced Technologies for Energy	APQ MiSE-CNR Ricerca di sistema, Progetto "Utilizzo di energia solare per il condizionamento estivo"		Ministry of Economic Development
Italy	EURAC	no funding	N/A	N/A
Italy	POLIMI	no funding	N/A	N/A
Netherlands	ECN			
Norway	Institute for Energy Technology IFE	IEA Heat Pump Programme Annex 34 - Thermally driven heat pumps for heating and cooling	SID 08/429	Enova SF
Switzerland	EPFL	Pompe à chaleur thermique à double cycle de Rankine	102849	Swiss Federal Office of Energy (SFOE)
UK	University of Warwick	CALEBRE (Consumer-Appealing Low Energy technologies for Building Retrofitting)	EP/G000387/1	Engineering and Physical Sciences Research Council
USA	University of Maryland	Alternative Cooling Technologies Consortium	N/A	Advanced Solar Cooling Concepts

6.2 Meetings

Table 6-2 gives an overview about the held meetings within Annex 34. In total ten expert meetings with an average participation rate of about 80% of the member countries. Moreover, several small working groups meeting were performed, not listed here.

Table 6-2: List of Annex 34 meetings

Meeting	City	Country
Kick-off-Meeting	Freiburg	Germany
1. Expert meeting	Alkmaar	Netherlands
2. Expert meeting	Bolzano	Italy
3. Expert meeting	Vienna	Austria
4. Expert meeting and joint meeting with IEA SHC Task 38	Freiburg	Germany
5. Expert meeting	Valladolid	Spain
6. Expert meeting	Munich	Germany
7. Expert meeting	Oslo	Norway
8. Expert meeting	Padova	Italy
9. Expert meeting	Warwick	United Kingdom

Besides the consortium meetings the management reported regularly to the ExCo in personal meetings and intermediate reports.

6.3 Other publications

Many papers have been published within the Annex 34 framework. Some of this work was cited in this report. Other publications without making claim to be complete are listed here:

Simulation

- (Cortés 2011)

Work regarding Organic ranking cycles:

- (Demierre and Favrat 2011)
- (Demierre and Favrat 2008)
- (Demierre, Henchoz et al. 2011)

State-of-the-art reports

- (Jakob and Kohlenbach 2010)

Gas fired heat pumps

- (Kühn 2011)

Component and system technology

- (Schwerdt, Pollerberg et al. 2010)
- (Frahn and Schwerdt 2010)
- (Brock, Fedrizzi et al. 2011)
- (Corrales Ciganda and Ziegler 2011)

Practice reports and lab scale measurements

- (Melograno, Santiago et al. 2009)
- (Sapienza, Glaznev et al. 2012)

Novel cooling concepts (ejector technology)

- (Scott, Aidoun et al. 2011)
- (Scott and Aidoun 2011)

CHCP-Technology

- (Kegel, Sunye et al. 2011)
- (Mittermaier, Petersen et al. 2010)
- (Zegenhagen, ner et al. 2009)
- (Zegenhagen, Corrales et al. 2010)

7 LITERATURE

- Aebischer, B., M. Jakob, et al. (2007). Impact of climate change on thermal comfort, heating and cooling energy demand in Europe. ECEEE 2007 Summer Study Saving energy: 859-870.
- AGEB (2010). AGEB 2010.
- AHRI (1998). AHRI Standard 320-98 Water-Source Heat Pumps. AHRI. Arlington.
- AHRI (1998). AHRI Standard 325-98 Ground Water-Source Heat Pumps. AHRI. Arlington.
- AHRI (1998). AHRI Standard 330-98 Ground Source Closed-Loop Heat Pumps. AHRI. Arlington.
- AHRI (2000). ANSI/ARI 560: Standard for Absorption Water Chilling and Water Heating Packages. AHRI. Arlington.
- Aidoun, Z., D. Giguère, et al. (2011). EJECTOR APPLICATIONS IN REFRIGERATION AND HEATING: AN OVERVIEW OF MODELING, OPERATION AND RECENT DEVELOPMENTS. 10th IEA Heat Pump Conference, 16 - 19 May 2011; Tokyo, Japan.
- Alefeld, G. a. R., R. (1994). Heat conversion systems. Boca Raton, CRC Press.
- ANSI (2008). ANSI/ASHRAE 182-2008: Method of Testing Absorption Water-Chilling and Water-Heating Packages. ANSI. New York.
- ANSI (2009). ANSI/ASHRAE Standard 37-2009 Methods of Testing for Rating Electrically Driven Unitary Air-Conditioning and Heat Pump Equipment. ANSI. New York.
- Aristov, Y. I. (2009). "Optimal adsorbent for adsorptive heat transformers: Dynamic considerations." International Journal of Refrigeration-*Revue Internationale Du Froid* **32**(4): 675-686.
- Aristov, Y. I., G. Restuccia, et al. (2002). "A family of new working materials for solid sorption air conditioning systems." Applied Thermal Engineering **22**(2): 191-204.
- Aristov, Y. I., A. Sapienza, et al. (2012). "Reallocation of adsorption and desorption times for optimisation of cooling cycles." International Journal of Refrigeration-*Revue Internationale Du Froid* **35**(3): 525-531.
- Aristov, Y. I., M. M. Tokarev, et al. (2006). "Kinetics of water adsorption on silica Fuji Davison RD." Microporous and Mesoporous Materials **96**(1-3): 65-71.
- Bauer, J., R. Herrmann, et al. (2009). "Zeolite/aluminum composite adsorbents for application in adsorption refrigeration." International Journal of Energy Research **33**(13): 1233-1249.
- Bauer, M., S. Plura, et al. (2008). DESIGN AND EXPERIMENTAL INVESTIGATION OF A HIGH-TEMPERATURE REGENERATOR FOR EFFICIENT TRI-GENERATION. International sorption heat pump conference, 23-26 September 2008; Seoul, Korea.
- Becker, M. a. H., Martin and Schweigler, Christian (2009). D-A2: Collection of selected systems schemes "Generic Systems" - A technical report of subtask A (Pre-engineered systems for residential and small commercial applications), IEA SHC Task 38 Solar Air Conditioning and Refrigeration.
- Bohenschäfer, W. (2011). Gaswärmepumpen – Aus der Nische in den Wärmemarkt, Effizienzdialog Zukunftstechnologie Gaswärmepumpe. Dresden.
- Bonaccorsi, L., A. Freni, et al. (2006). "Zeolite coated copper foams for heat pumping applications." Microporous and Mesoporous Materials **91**(1-3): 7-14.
- Brock, R., R. Fedrizzi, et al. (2011). Heat rejection control strategy for stationary tests of discontinuous thermally driven chillers.

- Cacciola, G. and G. Restuccia (1995). "Reversible Adsorption Heat-Pump - a Thermodynamic Model." International Journal of Refrigeration-Revue Internationale Du Froid **18**(2): 100-106.
- CEN (2000). EN12309-2:2000 Gas-fired absorption and adsorption air-conditioning and/or heat pump appliances with a net heat input not exceeding 70 kW – Part 2: Rational use of energy. CEN. Brussels.
- CEN (2007). EN 15316-2-3: 2007 Heating systems in buildings. Method for calculation of system energy requirements and system efficiencies. Heat generation systems, thermal solar systems. . Brussels, CEN.
- CEN (2007). EN 15316-3-3: 2007 Heating systems in buildings. Method for calculation of system energy requirements and system efficiencies. Domestic hot water systems, generation. Brussels, CEN.
- CEN (2008). EN15316-4-2:2008 Heating systems in buildings – Method for calculation of system energy requirements and system efficiencies – Part 4-2: Space heating generation systems, heat pump systems. CEN. Brussels.
- CEN (2011). EN14825:2011 Air conditioners, liquid chilling packages and heatpumps, with electrically driven compressors, for space heating and cooling – Testing and rating at part load conditions and calculation of seasonal performance. CEN. Brussels.
- CEN (2011). EN 14511:2011 Air conditioners, liquid chilling packages and heat pumps with electrically driven compressors for space heating and cooling. CEN. Berlin.
- CEN (2011). EN 16147:2011 Heat pumps with electrically driven compressors - Testing and requirements for marking for domestic hot water units. CEN. Brussels.
- Chua, H. T., K. C. Ng, et al. (2004). "Transient modeling of a two-bed silica gel-water adsorption chiller." International Journal of Heat and Mass Transfer **47**(4): 659-669.
- Corrales Ciganda, J. L. and F. Ziegler (2011). Control strategies for heat driven chillers to reduce parasitic electric consumption. 2nd European Conference on Polygeneration, 30th March - 1st April 2011; Tarragona, Spain.
- Cortés (2011). Modelling of an adsorption system for chilled water production driven by waste heat. Comparison with experimental results. 2nd European Conference on Polygeneration, 30th March - 1st April 2011; Tarragona, Spain.
- Critoph, R. E. and S. J. Metcalf (2011). PROGRESS IN THE DEVELOPMENT OF A CARBON-AMMONIA ADSORPTION GAS-FIRED DOMESTIC HEAT PUMP. International Sorption Heat Pump Conference, May 2011; Padua, Italy.
- Critoph, R. E. and Y. Zhong (2005). "Review of trends in solid sorption refrigeration and heat pumping technology." Proceedings of the Institution of Mechanical Engineers Part E-Journal of Process Mechanical Engineering **219**(E3): 285-300.
- Dahmani, A., Z. Aidoun, et al. (2011). "Optimum design of ejector refrigeration systems with environmentally benign fluids." International Journal of Thermal Sciences **50**(8): 1562-1572.
- Dawoud, B. (2010). WATER VAPOR ADSORPTION KINETICS ON SMALL AND FULL SCALE ZEOLITE COATED ADSORBERS; A COMPARISON. International Symposium on Innovative Materials for Processes in Energy Systems - For Fuel Cells, Heat Pumps and Sorption Systems, November 29 - December 1 2010; Singapore.

- Dawoud, B. (2011). "Gas-driven sorption heat pumps - a potential trend-setting heating technology." IEA Heat Pump Centre Newsletter **29**(1/2011): 18-22.
- Dawoud, B. (2012). Water vapor adsorption kinetics on small and full scale zeolite coated adsorbers; A comparison. Applied Thermal Engineering.
- Dawoud, B. and Y. Aristov (2003). "Experimental study on the kinetics of water vapor sorption on selective water sorbents, silica gel and alumina under typical operating conditions of sorption heat pumps." International Journal of Heat and Mass Transfer **46**(2): 273-281.
- Dawoud, B., P. Höfle, et al. (2010). EXPERIMENTAL INVESTIGATION OF THE EFFECT OF ZEOLITE COATING THICKNESS ON THE PERFORMANCE OF A NOVEL ZEOLITE-WATER ADSORPTION HEAT PUMP MODULE. International Conference for Enhanced Building Operations, 26-28 October 2010; Texas, USA.
- Dawoud, B., U. Vedder, et al. (2007). "Non-isothermal adsorption kinetics of water vapour into a consolidated zeolite layer." International Journal of Heat and Mass Transfer **50**(11-12): 2190-2199.
- Demierre, J. and D. Favrat (2008). LOW POWER ORC-ORC SYSTEMS FOR HEAT PUMP APPLICATIONS. 9th International IEA Heat Pump Conference, 20 - 22 May 2008; Zürich, Switzerland.
- Demierre, J. and D. Favrat (2011). THEORETICAL STUDY OF THERMALLY DRIVEN HEAT PUMPS BASED ON DOUBLE ORGANIC RANKINE CYCLE: WORKING FLUID COMPARISON AND OFF-DESIGN SIMULATION. 10th IEA Heat Pump Conference, 16 - 19 May 2011; Tokyo, Japan.
- Demierre, J., S. Henchoz, et al. (2011). "Prototype of a thermally driven heat pump based on integrated Organic Rankine Cycles (ORC)." Energy doi: 10.1016/j.energy.2011.1008.1049.
- Demierre, J., S. Henchoz, et al. (2012). "Prototype of a thermally driven heat pump based on integrated Organic Rankine Cycles (ORC)." Energy **41**(1): 10-17.
- Dieryckx, M. (2011). New Refrigerants in heat pumps – Perspective of a leading equipment manufacturer. 4th EHPA European Heat Pump Conference. London-Paddington.
- DIN (1988). DIN 33830-4:1988 Wärmepumpen; Anschlußfertige Heiz-Absorptionswärmepumpen; Leistungs- und Funktionsprüfung. DIN. Berlin.
- Dubinín, M. M. (1975). "Physical adsorption of gases and vapors in micropores." Progress in Surface and Membrane Science **9**: 1-70.
- ECO-MAX. (2012). "ECO-MAX adsorption chillers." 2012, from <http://www.eco-maxchillers.com/>.
- Ehrenmann, J., S. K. Henninger, et al. (2011). "Water Adsorption Characteristics of MIL-101 for Heat-Transformation Applications of MOFs." European Journal of Inorganic Chemistry **2011**(4): 471-474.
- Energy, U. S. D. o. Natural Gas Consumption by End Use. U. S. D. o. Energy.
- Fedrizzi, R., I. Malenković, et al. (2012). Uniform representation of system performance for solar hybrid systems. International Conference on Solar Heating and Cooling for Buildings and Industry. San Francisco, USA.
- Feuerecker, G. (1994). Entropieanalyse für Wärmepumpensysteme: Methoden und Stoffdaten.
- Fischedick, M. (2011). Der Energieträger Erdgas – Lösungsbeiträge vor dem Hintergrund des neuen Energiekonzepts. Effizienzdialog Zukunftstechnologie Gaswärmepumpen.

- Frahn, G.-M. and P. Schwerdt (2010). Enhanced Hybrid Dry Cooler for Solar Cooling - Self Cleaning Surface Modifications. EuroSun, 28 September - 1 October 2010; Graz, Austria.
- Frank, E., M. Haller, et al. (2010). Systematic classification of combined solar thermal and heat pump systems. International Conference on Solar Heating, Cooling and Buildings 2010, Graz, Austria.
- Freni, A., L. Bonaccorsi, et al. (2009). "Zeolite synthesised on copper foam for adsorption chillers: A mathematical model." Microporous and Mesoporous Materials **120**(3): 402-409.
- Freni, A., L. Bonaccorsi, et al. (2006). AN INNOVATIVE ADSORBER: ZEOLITE SYNTHESISED ON COPPER FOAM FOR ADSORPTION AIR CONDITIONING. International Conference on Heat Powered Cycles, 11-14 September 2006; Newcastle upon Tyne, UK.
- Freni, A., F. Russo, et al. (2007). "An advanced solid sorption chiller using SWS-11L." Applied Thermal Engineering **27**(13): 2200-2204.
- Füldner, G., L. Schnabel, et al. (2011). Numerical layer optimization of aluminum fibre/sapo-34 composites for the application in adsorptive heat exchangers. International Sorption Heat Pump Conference. R. M. Lazzarin, G. A. Longo and M. Noro. Padua, Italy, IIR/AICARR.
- Gluesenkamp, K., C. Horvath, et al. (2011). Air-cooled, single-effect, waste heat-driven water/LiBr absorption system for high ambient temperatures. International Sorption Heat Pump Conference, April 6-7-8, 2011; Padua, Italy.
- Gluesenkamp, K., Hwang, Y., Radermacher, R. (in press). "High efficiency micro trigeneration systems." Applied Thermal Engineering.
- Gluesenkamp, K. and R. Radermacher (2011). Heat-activated cooling technologies for small and micro combined heat and power (CHP) applications, Woodhead Publishing Limited.
- Gluesenkamp, K., R. Radermacher, et al. (2011). Crystallization inhibitors for water/LiBr absorption chillers. International Sorption Heat Pump Conference, April 6-7-8 2011; Padua, Italy.
- Gluesenkamp, K., R. Radermacher, et al. (2011). Trends in absorption machines. International Sorption Heat Pump Conference, April 6-7-8, 2011; Padua, Italy.
- Gluesenkamp, K., Radermacher, R., Hwang, Y. (2011). Preliminary design of a low regeneration temperature residential adsorption chiller. International Sorption Heat Pump Conference, Padua, Italy.
- Grisel, R. J. H., S. F. Smeding, et al. (2010). "Waste heat driven silica gel/water adsorption cooling in trigeneration." Applied Thermal Engineering **30**(8-9): 1039-1046.
- Groff, G. C. (2011) "North American Heat Pump Market Overview - 2011." http://www.ornl.gov/sci/ees/etsd/btrc/usnt/11-8-11Wkshp_presentations/Atlanta%20ExCo%20Workshop%20Talk.pdf.
- Hagel, K., M. Helm, et al. (2011). Performance of solar sorption cooling systems with heat rejection assisted by a latent heat storage. International Congress of Refrigeration, August 21 - 26 2011; Prague, Czech Republic.
- Helm, M. (2012). DIN: INS-Projekt solare Kühlung. E. m. f. n. o. s. cooling. Frankfurt, Germany, Fraunhofer ISE.
- Henninger, S. K., A. Freni, et al. (2011). Unified water adsorption measurement procedure for sorption materials. International Sorption Heat Pump Conference, April 6-7-8 2011; Padua, Italy.

- Henninger, S. K., H. A. Habib, et al. (2009). "MOFs as adsorbents for low temperature heating and cooling applications." Journal of the American Chemical Society **131**(8): 2776-2777.
- Henninger, S. K., F. Jeremias, et al. (2011). The potential of PCPs/MOFs for the use in Adsorption Heat Pump processes. International Sorption Heat Pump Conference (ISHPC11), Padova, Italy, IIR/AICARR.
- Henninger, S. K. and G. Munz (2009). HYDROTHERMAL STABILITY OF SORPTION MATERIALS AND COMPOSITES FOR THE USE IN HEAT PUMPS AND COOLING MACHINES. Heat Powered Cycles Conference, 7 to 9 September 2009; Berlin, Germany.
- Henninger, S. K., G. Munz, et al. (2011). "Hydrothermal Treatment of Sorption Materials - Implications on Adsorption Heat Pumps." Renewable Energy **36**: 3043-3049.
- Henninger, S. K., G. Munz, et al. (2011). "Cycle stability of sorption materials and composites for the use in heat pumps and cooling machines." Renewable Energy **Volume 36**(11): 3043-3049.
- Henninger, S. K., F. P. Schmidt, et al. (2010). "Water adsorption characteristics of novel materials for heat transformation applications." Applied Thermal Engineering **30**: 1692-1702.
- Henninger, S. K., F. P. Schmidt, et al. (2010). "Water adsorption characteristics of novel materials for heat transformation applications." Applied Thermal Engineering **30**(13): 1692-1702.
- Henninger, S. K., K. T. Witte, et al. (2011). Technical and Economical Review of Thermally driven heat pumps. 10th International Heat Pump Conference. Tokyo, Japan.
- Henninger, S. K., K. T. Witte, et al. (2011). Technical and Economical Review of Thermally driven heat pumps. 10th IEA Heat Pump Conference, 16 -19 May 2011; Tokyo, Japan.
- Herold, K. E., R. Radermacher, S. Klein (1996). Absorption Chillers and Heat Pumps. New York, CRC Press.
- Hiebler, S., H. Mehling, et al. (2009). LATENT HEAT STORAGE WITH MELTING TEMPERATURE 29 °C SUPPORTING A SOLAR HEATING AND COOLING SYSTEM. 11th international Conference on thermal energy storages; Stockholm, Sweden.
- Hu, X. (1998). "Departure-side spacing for liquid droplets and jet falling between horizontal circular tubes." Experimental and Thermal Fluid Science **16**: 322--331.
- Hu, X. and A. M. Jacobi (1996). "The intertube falling film .1. Flow characteristics, mode transitions, and hysteresis." Journal of Heat Transfer-Transactions of the Asme **118**(3): 616-625.
- Hutson, N. D. and R. T. Yang (1997). "Theoretical basis for the Dubinin-Radushkevitch (D-R) adsorption isotherm equation." Adsorption-Journal of the International Adsorption Society **3**(3): 189-195.
- Hwang, Y. H., R. Radermacher, et al. (2008). "Review of solar cooling technologies." Hvac&R Research **14**(3): 507-528.
- Isaac, M. and D. P. van Vuuren (2009). "Modeling global residential sector energy demand for heating and air conditioning in the context of climate change." Energy Policy **37**(2): 507-521.

- Jakob, U. (2010). Performance Analysis of small-scale sorption chillers. International Symposium on Innovative Materials for Processes in Energy Systems 2010 - For Fuel Cells, Heat Pumps and Sorption Systems Singapore.
- Jakob, U. (2011). "Sorption Cooling – a technology review." IEA Heat Pump Centre Newsletter **29**(4/2011).
- Jakob, U. and P. Kohlenbach (2010). Recent Developments of Sorption Chillers in Europe. 9th IIR-Gustav Lorentzen Conference on Natural Refrigerants, April 12-14, 2010; Sydney, Australia.
- Janchen, J., D. Ackermann, et al. (2002). "Adsorption properties of aluminophosphate molecular sieves - Potential applications for low temperature heat utilisation." Proceedings of the International Sorption Heat Pump Conference: 635-638.
- Jänchen, J., D. Ackermann, et al. (2004). "Studies of the water adsorption on Zeolites and modified mesoporous materials for seasonal storage of solar heat." Solar Energy **76**: 339-344.
- JSA (2011). JIS B 8622:2009 Absorption refrigerating machines. JSA. Tokyo.
- Kegel, M., R. Sunye, et al. (2011). ASSESSMENT OF A SORPTION CHILLER DRIVEN BY A COGENERATION UNIT IN A RESIDENTIAL BUILDING. International Sorption Heat Pump Conference, April 6-7-8, 2011; Padua, Italy.
- Kleemann, M. (2010). Potenzial der Gaswärmepumpentechnologie – Studie im Auftrag der Initiative Gaswärmepumpe. Berliner Energietage 12.05.2010. Berlin.
- Kotenko, O., H. Moser, et al. (2011). Thermodynamic analysis of ammonia/ionic liquid absorption heat pumping processes. International Sorption Heat Pump Conference. Padua, Italy.
- Kühn (2009). Ionic liquids - a promising solution for solar absorption chillers? International Conference Solar Air-Conditioning.
- Kühn (2011). A 10 kW INDIRECTLY FIRED ABSORPTION HEAT PUMP: CONCEPTS FOR A REVERSIBLE OPERATION. 10th IEA Heat Pump Conference.
- Malenkovic (2011). "Testing and performance evaluation methods for thermally driven heat pumps - Current work in IEA HPP Annex 34." IEA Heat Pump Centre Newsletter **29**(1/2011): 23-26.
- Malenković, I. (2012). Definition of Performance Figures for TDHP and Systems Including TDHP. IEA HPP Annex 34. T. R. B1.2.
- Malenković, I. (2012). Überblick über aktuelle Normen im Bereich thermisch angetriebene Wärmepumpen.
- Malenković, I., S. Eicher, et al. (2012). Proposal for the discussion on performance figures for solar and heat pump systems. Draft document for the deliverable B1 of the IEA SHC Task 44 / Annex 38 "Solar and Heat Pumps".
- Malenković, I., P. Melograno, et al. (2011). Current work within HPP Annex 34 on performance evaluation and testing methods of thermally driven heat pumps for heating and cooling. 10th IEA Heat Pump Conference. Tokyo, Japan.
- Malenković, I., M. Schicktanz, et al. (2012). Review of the existing standards and guidelines. Technical Report B1.1. I. H. A. 34.
- Malenković, I. and P. Schossig (2012). Prüf- und Bewertungsverfahren für Gaswärmepumpen. 3. VDI-Fachkonferenz Wärmepumpen – Umweltwärme effizient nutzen, Düsseldorf, Germany.
- Melograno, P. N., J. R. Santiago, et al. (2009). Experimental Analysis of a Discontinuous Sorption Chiller Operated in Steady Conditions. 3rd

- International Conference Solar Air-Conditioning, 30th September - 2nd October 2009; Palermo, Italy.
- Mittermaier, M., S. Petersen, et al. (2010). Primary Energy optimized operating strategies of Absorption Systems in CHCP networks. Sustainable Refrigeration and Heat Pump Technology Conference, 13-16 June 2010; Stockholm, Sweden.
- Moser, H. and R. Rieberer (2011). ANALYSIS OF A GAS-DRIVEN ABSORPTION HEAT PUMPING SYSTEM USED FOR HEATING AND DOMESTIC HOT WATER PREPARATION. 10th IEA Heat Pump Conference 2011, 16 - 19 May 2011; Tokyo, Japan.
- Moser, H., G. Zotter, et al. (2011). THE FORMATION OF NON-CONDENSABLE GASES IN AMMONIA/WATER ABSORPTION HEAT PUMPS MADE OF STAINLESS STEEL - LITERATURE REVIEW AND EXPERIMENTAL INVESTIGATION. International Conference Ammonia Refrigeration Technology, April 14-16 2011; Ohrid, Republic of Macedonia.
- Mugnier, D. (2012). "Task 48: Quality Assurance and Support Measures for Solar Cooling." Solar Heating & Cooling Programm SHC Retrieved 2012-08-15, 2012, from <http://www.iea-shc.org/task48/>.
- Munz, G. M., S. K. Henninger, et al. (2011). STABILITY OF ADSORPTION MATERIALS UNDER HYDROTHERMAL TREATMENT. International Sorption Heat Pump Conference, April 6-7-8 2011; Padua, Italy.
- Ng, E. P. and S. Mintova (2008). "Nanoporous materials with enhanced hydrophilicity and high water sorption capacity." Microporous and Mesoporous Materials **114**(1-3): 1-26.
- Nowak, T. M. P. (2011). OUTLOOK 2011 European Heat Pump Statistics. T. E. H. P. A. E. (EHPA).
- Núñez, T., H.-M. Henning, et al. (1999). Adsorption Cycle Modelling: Characterization and Comparison of Materials. International Sorption Heat Pump Conference.
- Núñez, T., I. Malenković, et al. (2011). Proposal for a performance calculation and evaluation procedure for solar cooling applications. 4th International Conference Solar Air-Conditioning, 12-14 October 2011; Larnaca, Cyprus.
- Okamoto, K., Teduka, M., Nakano, T., Kubokawa, S., Kakiuchi, H. (2010). The development of AQSOA water vapor adsorbent and AQSOA coated heat exchanger. Proceeding of Innovative Materials for Processes in Energy Systems IMPRES 2010, Singapore.
- Olonscheck, M., A. Holsten, et al. (2011). "Heating and cooling energy demand and related emissions of the German residential building stock under climate change." Energy Policy **39**(9): 4795-4806.
- Plura, S., M. Radspieler, et al. (2008). INNOVATIVE DOUBLE-EFFECT/SINGLE-EFFECT TRI-GENERATION SYSTEM - EXPERIENCE FROM THE FIRST YEAR OF OPERATION. International Sorption Heat Pump Conference, 23-26 September 2008; Seoul, Korea.
- Portal, E. s. E. (2009). Europe's Energy Portal: Natural gas consumption by country in 2009. .
- PRWeb "<http://www.prweb.com/pdfdownload/8592207.pdf>."
- Radspieler, M. and C. Schweigler (2011). Experimental investigation of ionic liquid EMIM EtSO₄ as solvent in a single-effect cycle with adiabatic absorption and desorption. International Sorption Heat Pump Conference, April 6-7-8 2011; Padua, Italy.

- Restuccia, G., A. Freni, et al. (1999). Adsorption beds of zeolite on aluminium sheets. International Sorption Heat Pump Conference. Munich, Germany: 343-347.
- Riepl, M., R. Gurtner, et al. (2011). Energetic and Economic Analysis of a Solarthermal-Assisted Energy System for Flexible Cooling and Heating. 4th International Conference Solar Air-Conditioning, 12-14 October 2011; Lanarca, Cyprus.
- Riepl, M., R. Gurtner, et al. (2011). Solar assisted cooling with a multi-stage absorption chiller. International Sorption Heat Pump Conference, April 6-7-8, 2011; Padua, Italy.
- Ristić, A., S. K. Henninger, et al. (2010). Microporous aluminophosphates: Promising materials for heat transformation applications. Eurosun. Graz, Austria.
- Saha, B. B., S. Koyama, et al. (2003). "Performance evaluation of a low-temperature waste heat driven multi-bed adsorption chiller." International Journal of Multiphase Flow **29**(8): 1249-1263.
- Sapienza, A., I. S. Glaznev, et al. (2012). "Adsorption chilling driven by low temperature heat: New adsorbent and cycle optimization." Applied Thermal Engineering **32**: 141-146.
- Sapienza, A., S. Santamaria, et al. (2011). "Influence of the management strategy and operating conditions on the performance of an adsorption chiller." Energy **36**: 5532-5538.
- Schicktzanz, M., P. Hugenell, et al. (2012). "Evaluation of methanol/activated carbons for thermally driven chillers, part II: The energy balance model." International Journal of Refrigeration-Revue Internationale Du Froid **35**(3): 554-561.
- Schicktzanz, M. and T. Núñez (2009). "Modelling of an adsorption chiller for dynamic system simulation." International Journal of Refrigeration **32**(4): 588-595.
- Schnabel, L., M. Tatlier, et al. (2010). "Adsorption kinetics of zeolite coatings directly crystallized on metal supports for heat pump applications (adsorption kinetics of zeolite coatings)." Applied Thermal Engineering **30**(11-12): 1409-1416.
- Schnabel, L., K. T. Witte, et al. (2011). EVALUATION OF DIFFERENT EVAPORATOR CONCEPTS FOR THERMALLY DRIVEN SORPTION HEAT PUMPS AND CHILLERS. International Sorption Heat Pump Conference, April 6-7-8 2011; Padua, Italy.
- Schneider, M.-C., R. Schneider, et al. (2011). Ionic liquids: new high-performance working fluids for absorption chillers and heat pumps. International Sorption Heat Pump Conference.
- Schossig P., W. K. T. (2011). "“Thermally driven heat pumps – Annexes, ongoing”." IEA Heat Pump Centre Newsletter **29**(No. 1/2011): 3, 13--14.
- Schwerdt, P., C. Pollerberg, et al. (2010). Small Scale Absorption Chiller using Membrane- and Nanotechnology, Fraunhofer Umsicht.
- Scott, D., Z. Aidoun, et al. (2011). "An experimental investigation of an ejector for validating numerical simulations." International journal of refrigeration **34**(7): 1717-1723.
- Scott, D. A. and Z. Aidoun (2011). CFD ANALYSIS OF AN EJECTOR FOR COOLING APPLICATIONS. International Congress of Refrigeration, August 21 - 26 2011; Prague, Czech Republic.
- Seiler, M., M.-C. Schneider, et al. (2010). New high-performance working pairs for absorption chillers and heat pumps. International Symposium on Innovative Materials for Processes in Energy Systems 2010 - For Fuel Cells, Heat Pumps and Sorption Systems.

- Sivak, M. (2009). "Potential energy demand for cooling in the 50 largest metropolitan areas of the world: Implications for developing countries." Energy Policy **37**(4): 1382-1384.
- Sparber, W., Napolitano, A (2010). Survey on existing SHC-plants - updated ppt-slide on Solar Cooling Installations. Work within IEA-SHC Task 38 'Solar Air-Conditioning and Refrigeration', <http://iea-shc-task38.org/documents/monitoring2>.
- Sparber, W., Thür, A., Besana, F., Streicher, W., Henning, H. M. (2008). Unified Monitoring Procedure and Performance Assessment for Solar Assisted Heating and Cooling Systems. Eurosun.
- Sparber, W., Vajen, K., Herkel, S., Ruschenburg, J., Thür, A., Fedrizzi, R., D'Antoni, M. (2011). Overview on solar thermal plus heat pump systems and review of monitoring results. Ises solar world congress 2011, Kassel, Germany.
- Srivastava, N. C. and I. W. Eames (1998). "A review of adsorbents and adsorbates in solid-vapour adsorption heat pump systems." Applied Thermal Engineering **18**(9-10): 707-714.
- Taylor, M. (2011). Technology Roadmap - Energy-efficient Buildings: Heating and Cooling Equipment. n. E. A. (IEA).
- Tischer, L. (2011). Thermally Activated Heat Pumps. 4th EHPA European Heat Pump Conference. London-Paddington.
- van Heyden, H., G. Munz, et al. (2009). "Kinetics of water adsorption in microporous aluminophosphate layers for regenerative heat exchangers." Applied Thermal Engineering **29**(8-9): 1514-1522.
- VDI (2003). VDI 4650-1: Calculation of heat pumps - Simplified method for the calculation of the seasonal performance factor of heat pumps - Electric heat pumps for space heating and domestic hot water. VDI. Düsseldorf.
- VDI (2003). VDI 4650-2: Simplified method for the calculation of the annual coefficient of performance and the annual utilisation ratio of sorption heat pumps - Gas heat pumps for space heating and domestic hot water. VDI. Düsseldorf.
- Wang, K., O. Abdelaziz, et al. (2011). "State-of-the-art review on crystallization control technologies for water/LiBr absorption heat pumps." International Journal of Refrigeration-Revue Internationale Du Froid **34**(6): 1325-1337.
- Wang, L. W., S. J. Metcalf, et al. (2012). "Development of thermal conductive consolidated activated carbon for adsorption refrigeration." CARBON **50**(3): 977-986.
- Wang, L. W., Z. Tamainot-Telto, et al. (2011). "Study of thermal conductivity, permeability, and adsorption performance of consolidated composite activated carbon adsorbent for refrigeration." Renewable Energy **36**(8): 2062-2066.
- Witte, K. T., F. Dammel, et al. (2011). Heat Loss Evaluation of an Experimental Set-up for predicting the Initial Stage of the Boiling Curve for Water at Low Pressure. COMSOL Conference 2011. Stuttgart.
- Witte, K. T., L. Schnabel, et al. (2009). Verdampferentwicklung für den Einsatz in thermisch betriebenen Kältemaschinen. Deutsche Kälte-Klima-Tagung 2009. Berlin.
- Witte, K. T., L. Schnabel, et al. (2011). Evaluation of different evaporator concepts for thermally driven sorption heat pumps and chillers. International Sorption Heat Pump Conference ISHPC 2011. Padua.
- Wuschig, C., S. Plura, et al. (2008). ABSORPTION CHILLER CYCLE ANALYSIS AND OPTIMIZATION BY NUMERICAL AND ANALYTICAL

- METHODS. International Sorption Heat Pump Conference, 23-26 September 2008; Seoul, Korea.
- Zachmeier, P., C. Schweigler, et al. (2011). Potential and Limits of Solar Thermal and Solar Electric Cooling. 4th International Conference Solar Air-Conditioning, 12-14 October 2011; Lanarca, Cyprus.
- Zegenhagen, T., J. Corrales, et al. (2010). BEST PRACTICE: DATA CENTER COOLING USING CHCP TECHNOLOGY. Sustainable Refrigeration and Heat Pump Technology Conference, 2010; Stockholm, Sweden.
- Zegenhagen, T., C. F. s. ner, et al. (2009). Heat2Cool-Cooling of charged inlet air with exhaust heat for internal combustion engines. Heat Powered Cycles, 7-9 September 2009; Berlin, Germany.
- Zhang, Y. H., Q. H. Liu, et al. (2005). "Properties and crystallization kinetics of poly(ether ether ketone)-co-poly(ether ether ketone ketone) block copolymers." Journal of Applied Polymer Science **97**(4): 1652-1658.
- Ziegler, B. (1984). "Equation of state for ammonia-water mixtures." Int. Journal of Refrigeration **7**(2): 101--106.
- Ziegler, F. (2002). "State of the art in sorption heat pumping and cooling technologies (Reprinted from Proceedings International Energy Agency Heat Pump Conference (IEAHPC 99), Berlin, 31, May-2 June, 1999)." International Journal of Refrigeration-Revue Internationale Du Froid **25**(4): 450-459.
- Zottl, A., R. Nordman, et al. (2011). System boundaries for SPF-calculation. 10th IEA Heat Pump Conference. Tokyo, Japan.



IEA Heat Pump Programme

Heat Pump Centre
c/o SP Technical Research Institute of Sweden
PO Box 857
SE-501 15 BORÅS
Sweden

Tel: +46 10 516 5512

Fax: +46 33 131 979

E-mail: hpc@heatpumpcentre.org

www.heatpumpcentre.org

Report no. HPP-AN34-1