

DESIGN AND APPLICATION OF AMMONIA HEAT PUMP SYSTEMS FOR HEATING AND COOLING OF NON-RESIDENTIAL BUILDINGS

*J. Stene, Research Scientist, SINTEF Energy Research, Dept. of Energy Processes
7465 Trondheim, NORWAY – Jorn.Stene@sintef.no*

Utilization of naturally occurring and ecologically safe substances as working fluids in heat pump systems represent an environmental friendly and long-term solution to the HFCs. The most important natural working fluids include ammonia, hydrocarbons and carbon dioxide. Ammonia heat pumps represent an energy efficient alternative for heating and cooling of non-residential buildings as well as for district heating and cooling systems.

This paper discusses the main characteristics of ammonia heat pump systems for heating and cooling of non-residential buildings including thermodynamic cycle analysis, recommended system design and dimensioning, component selection and system performance. The impact of the heat distribution system on system performance is also discussed. A number of large-capacity ammonia heat pump systems in Norway are presented including installations in office buildings, hospitals and district heating and cooling systems.

Key Words: *ammonia, heat pumps, non-residential buildings, design, applications*

1 INTRODUCTION

Ammonia (NH₃, R717) is the most well proven alternative among the natural working fluids since it has been extensively used in industrial refrigerating plants for more than a century. Ammonia heat pumps for heating and cooling of non-residential buildings achieve high energy efficiency due to the favourable thermophysical properties of the fluid. However, ammonia is a toxic fluid, and the strict standards and regulations for the construction and operation of ammonia refrigerating and heat pump systems have hampered its use in many countries. In Norway, ammonia has become a commonly used working fluid for medium- and large-capacity heat pumps with heating capacities ranging from about 200 kW to 8 MW.

2 MAIN CHARACTERISTICS OF AMMONIA HEAT PUMP SYSTEMS

2.1 Global Environmental Properties

Ammonia is an environmentally benign working fluid with zero ODP¹ and zero GWP². R407C and R134a, which are the most commonly used working fluids in Norwegian non-residential heat pump systems, have a GWP value of 1700 and 1300 respectively. The HFC working fluids are included in the Kyoto Protocol, and in e.g. Norway a CO₂ tax has been imposed according to the GWP value of the fluid, Table 1. In 2006 the European Union (EU) enforced the F-gas Regulation³ in order to reduce the leakage of e.g. HFCs from refrigerating and heat pump systems. The F-gas Regulation lays down minimum standards for the use of e.g. HFCs in the production, refilling, servicing or maintenance of equipment, as well as the

¹ ODP – Ozone Depletion Potential. ODP_{R11}=1.0

² GWP – Global Warming Potential. GWP_{CO2}=1.0

³ F-gas regulations – http://eur-lex.europa.eu/LexUriServ/site/en/oj/2006/L_161/L_16120060614en00120018.pdf

recovery and destruction of the fluids. Depending on the total HFC charge, the systems must be checked by qualified personnel at least every three months (>300 kg) to once a year (>3 kg). By 4 July, 2008, all EU Member States have to put in place own training and certification programmes for servicing staff handling HFCs. The adopted F-Gas Regulation bans the use of HFCs with a GWP potential of more than 150 in air conditioning systems in new motor vehicles from 2011, and from 2017 for all cars.

Table 1: GWP and CO₂ tax (Norway, 2007) for ammonia, propane and HFCs.

Working Fluid	GWP value	CO ₂ tax – Norway
R717 – ammonia	0	0
R407C	1700	40 €/kg
R134a	1300	31 €/kg

2.2 Material Compatibility

Hydrous ammonia is fully compatible with iron, steel, stainless steel and aluminium, but corrodes copper, zinc, and copper-based alloys (including brass). Consequently, structural steel and aluminium are the most commonly used materials in heat exchangers and pipelines in ammonia heat pump systems.

2.3 Required Compressor Volume

Ammonia has a very high specific enthalpy of evaporation [kJ/kg] compared to R407C and R134a. This results in a low mass flow rate [kg/s], which reduces the required dimensions of pipelines and valves by typically 30 to 50 % when assuming the same drop in saturation temperature. Despite the low vapour density of ammonia, the volumetric refrigerating capacity, VRC [kJ/m³] is relatively high. At -5 °C/50 °C evaporation/condensation temperature, the required compressor volume for R407C and R134a heat pump systems will be roughly 30 % and 90 % higher than that of an ammonia system, respectively. Figure 1 shows the volumetric refrigerating capacity for ammonia (R717), CO₂ (R744), propane (R290) and commonly used HFCs at different saturation temperatures (T).

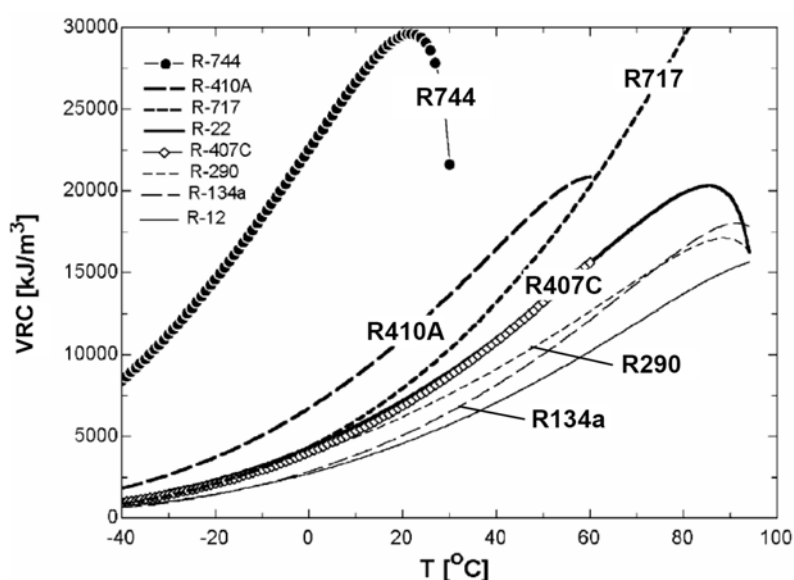

Figure 1: Volumetric refrigerating capacity (VRC) for selected working fluids (Kim et al., 2003).

2.4 Maximum Supply Temperature

The saturation temperature and pressure at evaporation and condensation are important properties when selecting a working fluid for a certain heat pump cycle. The saturated vapour pressure curve for ammonia is shown in Figure 2. Due to the relatively low normal boiling point (NBP=-33.3 °C) and high critical temperature ($t_c=132.2$ °C), ammonia covers a wide range of heat pumping applications from refrigerating systems to heat pumps.

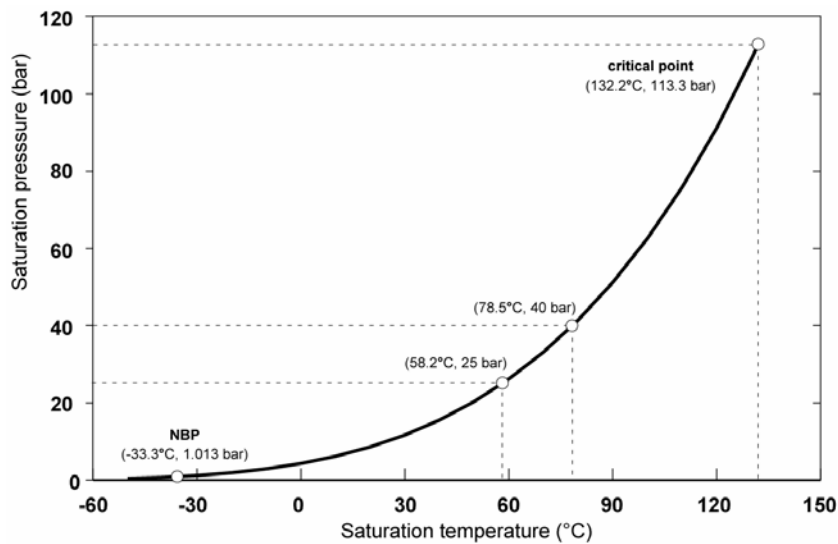

Figure 2: Saturation vapour pressure curve for ammonia (Stene, 1998).

Figure 3 shows the log p-h diagram for ammonia with condensation temperatures at 2.9, 25 and 40 bar operating pressure (CoolPack, 2008). The maximum operating pressure is typically 15-20 % lower than that of the set-point for the safety valve.

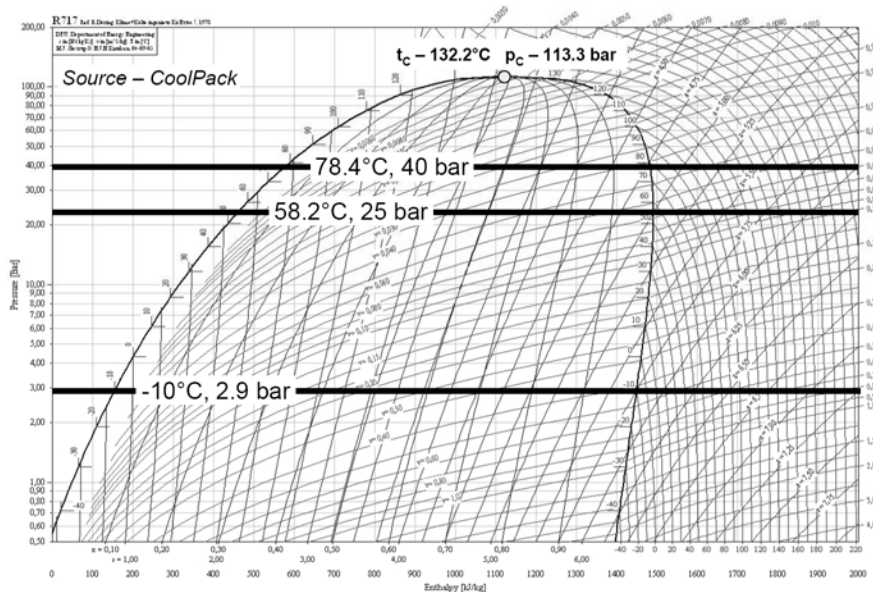

Figure 3: Log p-h diagram for ammonia (Coolpack, 2008).

One disadvantage with ammonia heat pumps is the limited supply water temperature of approximately 48 °C from the condenser when using standard 25 bar equipment (York, 2008). If the heat pump supplies heat to a high-temperature heat distribution hydronic

system, e.g. 80/60 °C or 70/50 °C at DOT⁴, the return temperature during longer periods may be even higher than the maximum supply temperature from the condenser. This will reduce the annual heat supply from the heat pump and with that the Seasonal Performance Factor (SPF) of the system. If 25 bar ammonia heat pumps are to be used for heating and cooling of buildings, it is of crucial importance that the hydronic heat distribution is designed for a relatively low return temperature. This can be achieved by designing the radiators for e.g. 80/50 °C in combination with serial connection of radiators and heating batteries in the ventilation system and possibly volume flow control of the primary water circuit.

By using a two-stage system design with 40 bar compressor and condenser in the second stage, the maximum supply water temperature is increased to about 68 °C (York, 2008). Two-stage operation will typically boost the SPF by as much as 20-40 %, but the costs are 80 to 100 % higher than that of single-stage systems. For a single-stage system with 40 bar compressor and condenser, the additional costs are about 15 to 25 % (York, 2008). Figure 4 shows, as an example, a two-stage ammonia heat pump cycle with full intercooling at intermediate pressure. The evaporation and condensing temperatures are -5 °C and 75 °C respectively, and the isentropic compressor efficiency is 75 % (Coolpack, 2008).

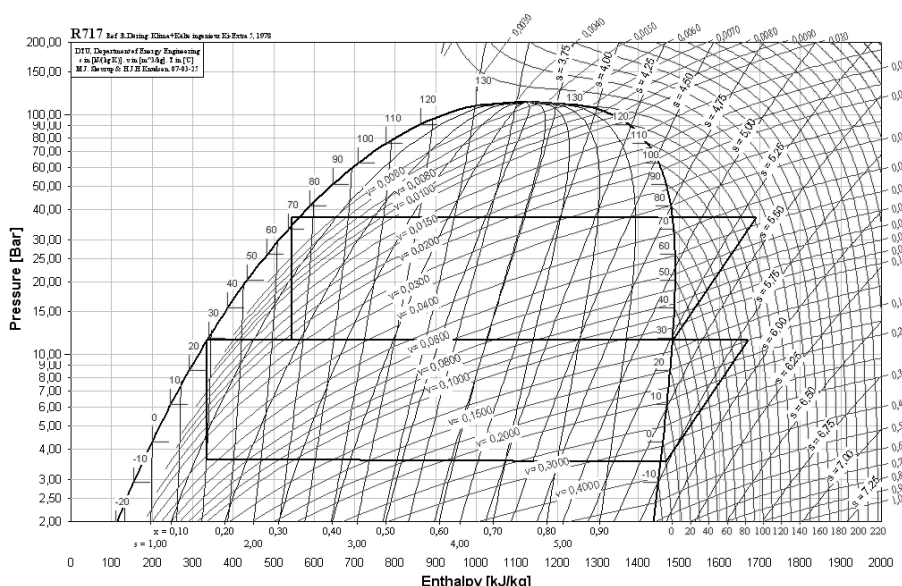

Figure 4: Two-stage ammonia heat pump cycle at -5 °C/75 °C evaporation/condensation temp., respectively. The isentropic compressor efficiency is 75 % (Coolpack, 2008).

2.5 Energy Efficiency – Coefficient of Performance (COP)

Ammonia heat pumps achieve a higher Coefficient of Performance (COP) than R407C and R134a systems at identical operating conditions. Example – for a theoretical single-stage heat pump cycle operating with -5 °C/50 °C evaporation/condensation temperature, isentropic and adiabatic compression and no suction superheat or sub-cooling, the COP of the ammonia cycle is about 7 % and 11 % higher than that of the R134a and R407C cycles (Coolpack, 2008). The difference will be even larger in real systems due to the favourable thermophysical properties of ammonia. This include steeper saturation temperature/pressure curve, superior heat transfer properties and high compressor efficiencies. At low pressure ratios, ammonia compressors are considerably better than HFC compressors, whereas relatively similar compressor efficiencies are achieved at high pressure ratios (Stene, 1998).

⁴ DOT – Design Outdoor Temperature

2.6 Discharge Gas Temperature

Due to the relatively low density and specific heat capacity of ammonia in the superheated vapour phase, the discharge gas temperature is considerably higher than that of the HFCs. Excessive temperatures may lead to chemical decomposition of the working fluid, carbonization of the lubricant and breakdown of gaskets. High discharge gas temperatures will also reduce the COP of the system. During normal operating conditions, the temperatures of the lubricant and the ammonia should not exceed 130 °C and 160 °C, respect. (Stene, 1998).

Figure 5 shows the discharge gas temperatures for ammonia, R22, R134a and R410A at various evaporation temperatures, assuming single-stage compression, 40 °C condensation temperature, 10 °C superheating and 70 % isentropic compressor efficiency (Stene, 1998).

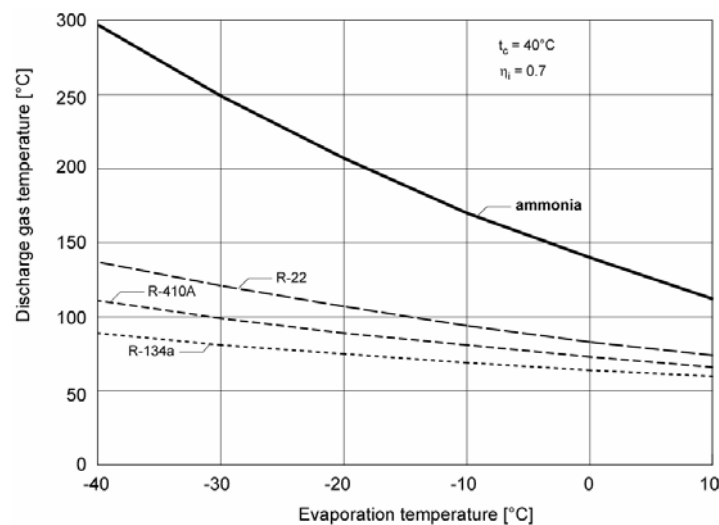

Figure 5: Discharge gas temperatures for ammonia, R22, R134a and R410A (Stene, 1998).

In order to ensure reliable and energy efficient operation of the compressor, different measures are of current interest including the application of:

- High-temperature heat source
- Low-temperature heat distribution system
- Enhanced surfaces for the evaporator and condenser
- Flooded evaporator operation
- Water-cooled cylinder heads for reciprocating compressors
- Two-stage plant design at compression ratios above 5 to 6
- Desuperheater for hot water production

2.7 Compressor Selection – Efficiency at Part Load Operation

Due to the considerable variations in the heating/cooling loads and the temperature requirements in the heat distribution system in buildings, ammonia heat pump systems should be designed for high energy efficiency at part load operation and varying condensation temperatures. This implies the application of minimum two heat pump units equipped with reciprocating compressors or inverter controlled screw-compressors with variable volume ratio. Conventional screw compressors with slide-valve control and fixed volume ratio

are not recommended due to the low energy efficiency at part load operation and varying temperature lift. Figure 6 shows the relative compressor efficiency at part load operation for a 200 kW reciprocating compressor with suction valve control and a 200 kW screw compressor with slide-valve control and fixed volume ratio (Oestreich, 2006).

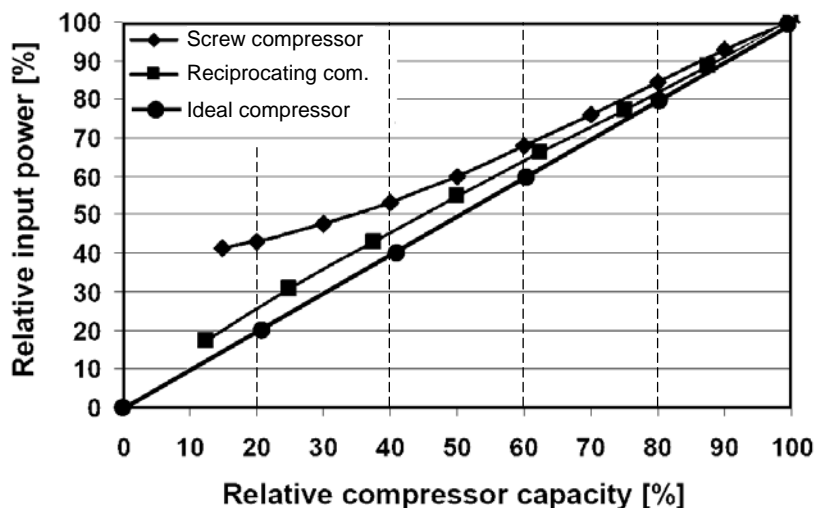

Figure 6: Efficiencies at part load operation for 200 kW reciprocating and screw compressors with suction valve control and slide-valve control, respectively (Oestreich, 2006).

Centrifugal compressors are not applicable in ammonia heat pump systems since the low molar mass (17.03) would require multiple-stage compression, about 6 times as many as for R134a system (Stene, 1998).

2.8 Safety Measures

The main arguments against the installation of ammonia heat pumps in densely populated areas are related to the consequences of possible uncontrolled ammonia emissions. Ammonia is a toxic fluid with a pungent odour. The Threshold Limit Value (TLV) is 25 ppm, the Immediate Danger for Life and Health (IDLH) value is 500 ppm, and the lowest fatal concentration reported is 5,000 ppm (Stene, 1998). Since the Lower Explosion Limit (LEL) and the Auto-Ignition Temperature (AIT) are as high as 15 % by volume and 651 °C, respectively, EN378 classifies ammonia in Group B2 together with working fluids that have lower flammability and higher toxicity. In order to ensure maximum safety in ammonia heat pump plants, a number of mandatory/optional safety measures must/may be implemented:

- Low-charge ammonia units (<0.1-0.2 kg/kW)
- Gas-tight and fire-proof machinery room with sufficient number of self-closing doors, alternatively a container on the roof of the building
- Leak detectors located above the heat pump units activating visual and audible alarm (ammonia is lighter than air, density ratio approx. 0.6 at 20 °C and 1.013 bar)
- Fail-safe emergency ventilation system with spark proof fan (suction at ceiling level, constant under-pressure around the ammonia units, exhaust delivered at safe distance from air inlets in ventilations systems)
- Ammonia scrubber for efficient absorption of ammonia vapour in the exhaust ventilation air (ammonia vapour is effectively absorbed in water)
- Various equipment – emergency lighting, fire extinguishers, personal protective equipment (goggles, gloves, protective clothing), emergency eye-wash fountain etc.

3 MARKET – INSTALLATION EXAMPLES

Several hundred ammonia heat pumps have been installed in Norway since the early 90'ies. Most installations are in larger buildings (200 kW to 2 MW) and in district heating and cooling systems (700 kW to 8 MW). There are also a considerable number of ammonia heat pumps in ice rink systems, industry (supercharge units, drying units) and fish farming plants. About 25 of the ammonia heat pump installations are two-stage 40 bar systems. The Directorate for Public Construction and Property in Norway (Statsbygg) prefers to install ammonia heat pumps, since ammonia is an environmentally friendly working fluid with excellent thermophysical properties.

3.1 Ammonia Heat Pump in a Research Centre (1994)

A 900 kW ammonia heat pump system for space heating, space cooling and hot water heating was installed in 1994 at the StatoilHydro Research Centre in Trondheim, Norway. The heating and cooling demands at design conditions for the 28,000 m² building are 1.50 and 1.35 MW, respectively. Sea water from 60 meters depth is used as heat source. Figure 7 shows a principle scheme of the ammonia heat pump system.

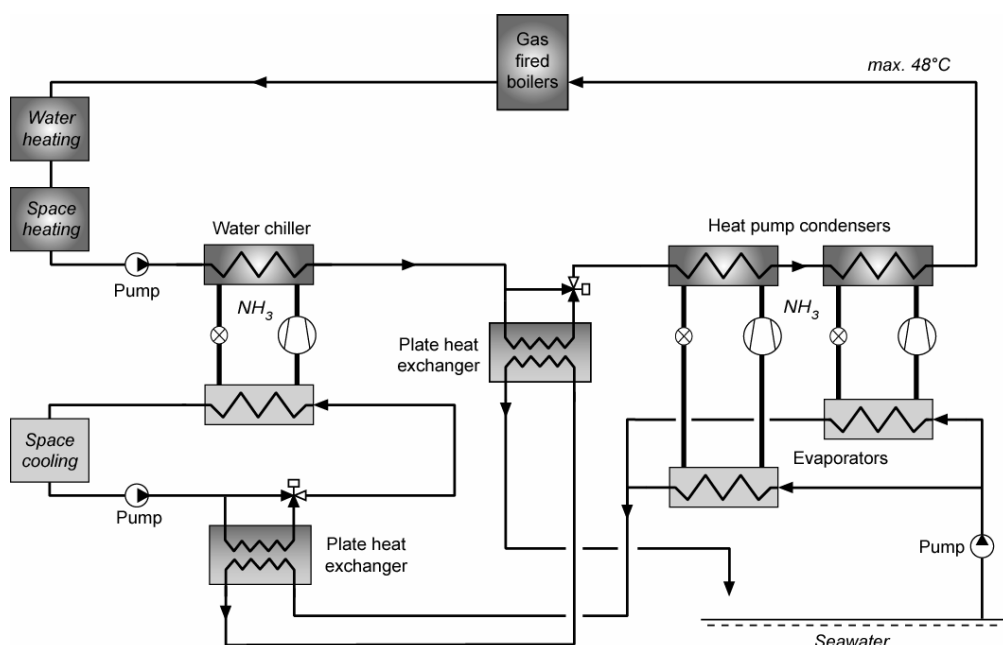

Figure 7: Principle scheme of the 900 kW ammonia heat pump system at StatoilHydro.

The heat pump comprises two identical single-stage heat pump units equipped with two 25 bar six cylinder reciprocating compressors, a titanium plate heat exchanger as evaporator and a two-pass shell-and-tube condenser. The ammonia charge is about 0.2 kg per kW heating capacity. Auxiliary heating and back-up is provided by gas-fired boilers. Since the machinery room is located inside the building on the ground floor, the room is gas-tight with self-closing doors. A two-stage ventilation system maintains constant under-pressure around the units. Other safety measures include leak detectors, an alarm system and a tailor-made ammonia scrubber. The scrubber is installed in the ventilation duct, and reduces the ammonia concentration in the exhaust air to 50 ppm in case of a major leakage.

Although the COP of the heat pump units is about 4.5 at design conditions, the SPF of the bivalent heating system is less than 2.5. The main reason for the poor performance is that the gas-fired boilers cover the entire heating load at low ambient temperatures, since the return temperature in the heat distribution system at these operating conditions is higher than

the maximum supply temperature of 48 °C from heat pump units. As a consequence, the heat pump system covers less than 80 % of the total annual heating demand of the building. This problem could have been resolved by using a two-stage 40 bar heat pump system – or even better, designing the hydronic heat distribution system for a lower return temperature.

3.2 Ammonia Heat Pump in a District Heating and Cooling System (1998)

Norway's largest ammonia chiller and heat pump system (CHPS) was installed at Oslo Airport Gardermoen in 1998 (Eggen and Vangsnes, 2005). The maximum heating and cooling capacity of the CHPS is 7.5 MW and 6.0 MW, respectively, and the system utilizes the vast ground-water aquifer in the area as a thermal energy storage (ATES). The ATES system consists of 9 cold wells and 9 warm wells. During winter mode, groundwater from the warm wells are used as heat source for the CHPS, and the return water is supplied to the cold wells. During summer mode, the ground water from the cold wells is used for pre-cooling before it is returned to the warm wells. Figure 8 shows a principle scheme of the heat pump system.

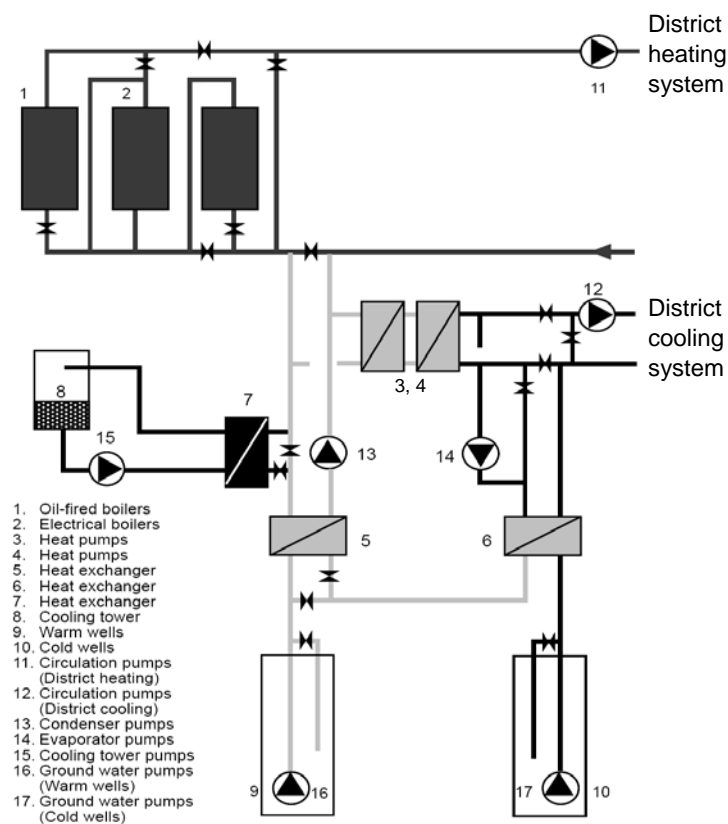

Figure 8: Principle scheme of the 7.5 MW ammonia heat pump system at Oslo Airport.

The two single-stage ammonia heat pump units are equipped with a shell-and-tube evaporator and condenser, although plate heat exchangers could have substantially reduced the ammonia charge. Seven 8- and 16-cylinder reciprocating compressors are used in order to achieve high efficiency at part load operation. The measured overall SPF for the CHPS in heating and cooling mode is about 5.5.

The total ammonia charge of the heat pump system is 2,500 kg. Due to the toxicity of the fluid and the considerable charge, the gas-tight energy central is located about 1 km from the terminal building and equipped with leak detectors, a fail-safe emergency ventilation system and a sprinkler system.

3.3 Ammonia Heat Pump System in a Hospital (2008)

The new University Hospital in Akershus (Ahus)⁵ is currently under construction and commissioning. The buildings have a total floor area of about 160.000 m², and the hospital will be fully operative from October 2008. The estimated annual heating demand is about 20 GWh/year. One of the goals during planning of the energy systems has been that min. 40 % of the supplied energy for heating and cooling should come from renewable energy sources.

A combined ammonia chiller and heat pump system (CHPS) will supply heating and cooling to the buildings, and the system will be connected to the largest underground thermal energy storage (UTES) in Europe, comprising 350 two hundred metres deep boreholes in bedrock (Sweco, 2008). The thermal storage is used as a high-quality heat source for the CHPS, and excess heat from the cooling system as well as excess heat from the ventilation air will be used to charge the storage thus maintaining the annual average storage temperature.

The CHPS from York Refrigeration will comprise three single-stage screw-compressor units with slide valve control and variable volume ratio, and one single-stage unit with two large reciprocating compressors. Each unit has a maximum cooling capacity of roughly 2 MW. Figure 9 shows a photo of one of the ammonia screw compressor units.



Figure 9: Ammonia screw compressor unit at the new University Hospital in Akershus.

The CHPS is designed according to a maximum cooling load of about 7.7 MW, and the heating capacity at design outdoor temperature (DOT) is about 8 MW. The units will be supplying condenser heat to a low-temperature circuit at a maximum supply temperature of 52 °C (space heating, heating of swimming pools etc.), and desuperheat to a high-temperature circuit at a maximum supply temperature of 75 °C (hot water heating). The heating system is designed as a bivalent system. The heat pump system will cover about 85 % of the total annual heating demand of the hospital, whereas oil-fired and electric boilers will be used as peak load covering the remaining 15 %.

4 DISCUSSION AND CONCLUSION

Ammonia (R717, NH₃) is a working fluid with zero ODP and zero GWP. Due to the favourable thermophysical properties of the fluid, ammonia heat pumps for heating and cooling of commercial buildings achieve high energy efficiency. In Norway, more than 200 medium- and large-capacity ammonia heat pumps (200 kW – 8 MW) have been installed in recent years.

⁵ SiA – http://www.nyeahus.no/modules/module_123/proxy.asp?D=2&C=339&I=1330&mids=184a357

The maximum supply water temperature from ammonia heat pumps using standard 25 bar equipment is about 48 °C. In order to ensure maximum annual heat supply from the heat pumps when they are installed in high-temperature radiator systems it is crucial that the hydronic heat distribution is designed for a relatively low return temperature. By using a two-stage system design with 40 bar compressor and condenser in the second stage, the maximum supply water temperature is increased to about 68 °C. Two-stage operation boosts the SPF by 20-40 %, but the costs are 80 to 100 % higher than that of single-stage systems.

The discharge gas temperature of ammonia is considerably higher than that of the HFCs. In order to ensure reliable and energy efficient operation of the compressor, different measures are of current interest including the application of a low-temperature heat distribution system, enhanced surfaces for the evaporator and condenser, flooded evaporator design, water-cooled cylinder heads for reciprocating compressors, two-stage plant design at compression ratios above 5 to 6 and desuperheater for hot water production.

In order to achieve good part load efficiency, ammonia heat pumps should use minimum two heat pump units equipped with reciprocating compressors or inverter controlled screw-compressors with variable volume ratio. Conventional screw compressors with slide-valve control and fixed volume ratio are not recommended due to the low energy efficiency at part load operation and varying temperature lift. Centrifugal compressors are not applicable in ammonia heat pump systems due to the low molar mass of the fluid.

Ammonia is a highly toxic fluid with a pungent odour. In order to ensure maximum safety in ammonia heat pump systems, a number of mandatory/optional safety measures must/may be implemented including low-charge ammonia units (<0.1-0.2 kg/kW), a gas-tight and fire-proof machinery room alternatively a container on the roof of the building, leak detectors, a fail-safe emergency ventilation system, and an ammonia scrubber for efficient absorption of ammonia vapour in the exhaust ventilation air in case of a major leakage.

5 REFERENCES

- CoolPack, 2000. *Simulation programme for heat pump and refrigerating systems*. Developed at the Technical University of Denmark, Department of Mechanical Engineering (free-ware). <http://www.et.web.mek.dtu.dk/Coolpack/UK/reg-download.html>
- Eggen, G., Vangsnes, G., 2005. *Heat pump for district cooling and heating at Oslo, Airport Gardermoen*. Proceedings from the 8th IEA Heat Pump Conference, May 2005. Las Vegas, USA.
- Kim M.H., Pettersen, J.W., Bullard, C., 2004. *Fundamental Process and System Design Issues in CO₂ Vapour Compression Systems*. Energy and Combustion Science, Volume 30 2004, pp. 119-174.
- Oestreich, S.G., 2006: *Analysis of a Large-Scale Ground-Source Heat Pump System for Heating and Cooling of Buildings*. Master thesis at the Norwegian University of Science and Technology (NTNU), Dept. of Energy and Process Engineering. EPT-M-2006-56.
- Stene, J., 1998. *IEA Annex 22: Final Report – Guidelines for Design and Operation of Compression Heat Pump, Air Conditioning and Refrigerating Systems with Natural Working Fluids*. IEA HPP Report No. HPP-AN22-4. ISBN 90-73741-31-9.
- Sweco, 2008. Information from Sweco Grøner AS, Norway
- York, 2008. Information from York Refrigeration, Norway